



CLARK COUNTY PEDESTRIAN STUDY

*Las Vegas Boulevard
Russell Road to Sahara Avenue*

NOVEMBER 2012



Kimley-Horn
and Associates, Inc.

PEDESTRIAN STUDY

LAS VEGAS BOULEVARD

RUSSELL ROAD TO SAHARA AVENUE

Prepared for:



500 S. Grand Central Parkway
Las Vegas, NV 89115-4000

Prepared By:



6671 Las Vegas Boulevard South, Suite 320, Las Vegas, NV 89119
Tel 702-862-3600 www.kimley-horn.com

November 2012

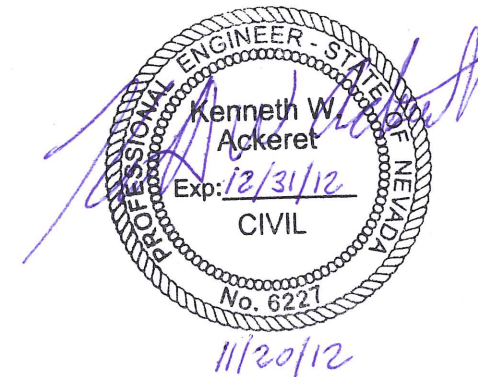

TABLE OF CONTENTS

1	Introduction	1	3.2	Walking Speeds	79
1.1	Study Purpose	1	3.2.1	Walking Speeds on Pedestrian Bridges.....	88
1.2	Study Goals	1	3.3	Non-Permanent Obstructions.....	91
1.3	Study Corridor.....	1	3.3.1	Non-Permanent Obstructions on Walkways.....	91
1.4	Literature Review.....	1	3.3.2	Non-Permanent Obstructions on Pedestrian Bridges	98
1.4.1	Technical Literature.....	2	3.4	Bus Stop Queuing	101
1.4.2	Background Literature	4	3.5	Pedestrian Simulation Modeling	104
2	Study Approach and Methodology	8	3.5.1	Model 1 – Pedestrian Bridge.....	105
2.1	Existing Conditions.....	8	3.5.2	Model 2 – Sidewalk	106
2.1.1	Public Right-of-Way and Pedestrian Easements	8	3.5.3	Model 3 – Sidewalk and Bus Stop	107
2.1.2	Existing Walkway Widths (W)	8	3.5.4	Model 4 – Queuing at a Signalized Crosswalk.....	109
2.1.3	Newsracks.....	10	3.5.5	Results of Pedestrian Simulation Modeling.....	110
2.1.4	Bus Stops.....	12	3.5.6	Findings	110
2.1.5	Pedestrian/Vehicle Crash Data	14	3.6	Walkway Segment Time of Day Restriction Analysis	115
2.1.6	Pedestrian Containment.....	17	4	Conclusions and Recommendations	137
2.1.7	Construction Activities	19	4.1	General Conclusions and Recommendations.....	137
2.2	Data Collection	21	4.1.1	Safety Enhancements	137
2.2.1	Pedestrian Counts - Video	23	4.2	Infrastructure Improvement Recommendations.....	139
2.2.2	Pedestrian Counts - Manual	24	4.3	Recommended Updates to No-Obstructive Use Zones	143
2.2.3	Pedestrian Walking Speeds.....	25	4.3.1	Recommended Time, Place, and Manner No – Obstructive Use Zones.....	143
2.2.4	Non-Permanent Obstructions	27			
2.3	Data Analysis Methodology	29			
2.3.1	Pedestrian Volume Analysis – Level of Service Calculations	29			
2.3.2	Walking Speed Analysis Methodology	30			
2.3.3	Bus Stop Queuing Analysis Methodology	30			
2.4	Pedestrian Simulation Model	30			
2.4.1	Model Background	30			
2.4.2	Model Methodology	30			
3	Data Evaluation	31			
3.1	Pedestrian Volumes	31			
3.1.1	Evaluation Summary	31			
3.1.2	Outer Portion of the Study Corridor.....	35			
3.1.3	Inner Portion of the Study Corridor	45			
3.1.4	Pedestrian Bridges	62			
3.1.5	Pedestrian Volume Level of Service.....	77			

APPENDIX

The report appendices are provided on the disk in the back of the report.

LIST OF TABLES

Table 1.1 – Walking Speed LOS from 2010 HCM.....	3	Table 3.18 – Average Walking Speed – East Pedestrian Bridges – 6/16/2012 (Typical Saturday).....	88
Table 1.2 – Typical Fixed-Object Effective Widths from 2010 HCM.....	4	Table 3.19 – Observed Non-Permanent Obstructions (May 26, 2012)	91
Table 1.3 – Flow Rate LOS from 2010 HCM.....	4	Table 3.20 – Observed Non-Permanent Obstructions (June 16, 2012)	91
Table 1.4 – Pedestrian Level of Service from 1985 Highway Capacity Manual	5	Table 3.21 – Distribution of Non-Permanent Obstructions 5PM – 8PM (May 26, 2012)	91
Table 1.5 – Pedestrian Counts along Las Vegas Boulevard.....	6	Table 3.22 – Distribution of Non-Permanent Obstructions 5PM – 8PM (June 16, 2012)	91
Table 2.1 – Bus Stop Summary	12	Table 3.23 – Non-Permanent Obstructions by Percentage 5PM – 8PM (May 26, 2012)	91
Table 2.2 – Pedestrian Level of Service.....	29	Table 3.24 – Non-Permanent Obstructions by Percentage 9PM – 12AM (June 16, 2012)	91
Table 2.3 – LOS and Average Speed Values.....	30	Table 3.25 – Non-Permanent Obstructions on West Pedestrian Bridges – Holiday Saturday (5/26/2012)	98
Table 2.4 – Shared Bus Stops within Resort Corridor.....	30	Table 3.26 – Non-Permanent Obstructions on East Pedestrian Bridges – Holiday Saturday (5/26/2012)	98
Table 3.1 – Data Summary for Outer Portion of the Study Corridor.....	35	Table 3.27 – Non-Permanent Obstructions on West Pedestrian Bridges – Typical Saturday (6/16/2012)	98
Table 3.2 - Data Summary for Inner Portion of the Study Corridor.....	46	Table 3.28 – Non-Permanent Obstructions on East Pedestrian Bridges – Typical Saturday (6/16/2012)	98
Table 3.3 – Data Summary for Pedestrian Bridges.	62	Table 3.29 – Bus Stops Included in Queuing Analysis	101
Table 3.4 – Pedestrian Volume Count Locations that Exceeded LOS C	77	Table 3.30 – Bus Stop Max Boardings and Queue Area	101
Table 3.5 – Free-flow Walking Speeds	79	Table 3.31 – Analyzed Bus Stops with Adequate Queue Area	101
Table 3.6 – LOS and Average Speed Values.....	79	Table 3.32 – Analyzed Bus Stops with Inadequate Queue Area.....	101
Table 3.7 – Free-flow Walking Speed – West Segments	79	Table 3.33 – Model 1 – Pedestrian Bridge Input Data -15-Minute Pedestrian Volume.....	105
Table 3.8 – Free-flow Walking Speed – East Segments	80	Table 3.34 – Model 2 – Sidewalk Input Data -15-Minute Pedestrian Volume	106
Table 3.9 – Average Walking Speed – West Segments – 5/26/2012 (Holiday Saturday)	80	Table 3.35 – Model 3 – Sidewalk Input Data -15-Minute Pedestrian Volume	107
Table 3.10 – Average Walking Speed – East Segments – 5/26/2012 (Holiday Saturday).....	80	Table 3.36 – Model 3 – Bus Stop Boarding and Alighting Data – 15-Minute Boarding/Alighting.....	107
Table 3.11 – Average Walking Speed – West Segments – 6/16/2012 (Typical Saturday)	81	Table 3.37 – Model 4 – Queuing at a Signalized Intersection Input Data -15-Minute Pedestrian Volume	109
Table 3.12 – Average Walking Speed – East Segments – 6/16/2012 (Typical Saturday)	81	Table 3.38 – Pedestrian Simulation Modeling Color Codes.....	110
Table 3.13 – Free-flow Walking Speed – West Pedestrian Bridges.....	88	Table 3.39 – Model 1 Results Summary – 3:00 PM to 12:00 AM	110
Table 3.14 – Free-flow Walking Speed – East Pedestrian Bridges.....	88	Table 3.40 – Model 2 and 3 Results Summary – 3:00 PM to 12:00 AM.....	110
Table 3.15 – Average Walking Speed – West Pedestrian Bridges – 5/26/2012 (Holiday Saturday).....	88	Table 3.41 – Walkways which Exceed LOS C - Time of Day, Day of Week, and Month of Year	135
Table 3.16 – Average Walking Speed – East Pedestrian Bridges – 5/26/2012 (Holiday Saturday)	88	Table 3.42 – Walkways which Exceed LOS C - Time of Day, Day of Week, and Month of Year (with an obstruction). 136	
Table 3.17 – Average Walking Speed – West Pedestrian Bridges – 6/16/2012 (Typical Saturday)	88		

LIST OF PICTURES

Picture 1.1 – Pedestrian Activity Level (Memorial Day Weekend 2012).	2	Picture 2.25 – JAMAR Count Board for Manual Pedestrian Volume Counts.	24
Picture 1.2 – Existing Ordinance Sign on Las Vegas Boulevard.	6	Picture 2.26 – Typical Pedestrian Conditions at North end of Study Corridor.	24
Picture 2.1 – Example of walkway with public ROW, pedestrian easement and private walkway.	8	Picture 2.27 – Typical Pedestrian Conditions at South end of Study Corridor.	24
Picture 2.2 – Newsracks at Front of Walkway.	10	Picture 2.28 – Pedestrian Agent during Walking Data Collection (west “Strip” northbound).	25
Picture 2.3 – Newsracks at Back of Walkway.	10	Picture 2.29 – Pedestrian Agent during Walking Data Collection (east “Strip” southbound).	25
Picture 2.4 – Newsracks against Pedestrian Containment.	10	Picture 2.30 – Examples of Hand billers observed on Las Vegas Boulevard.	27
Picture 2.5 – SDX and DEUCE Buses at Wynn Bus Stop.	12	Picture 2.31 – Examples of Performers observed on Las Vegas Boulevard.	27
Picture 2.6 – Emergency Vehicles on Las Vegas Boulevard.	14	Picture 2.32 – Examples of Solicitors observed on Las Vegas Boulevard.	28
Picture 2.7 – Vehicle Activity on Holiday Saturday of Memorial Day Weekend 2012.	14	Picture 2.33 – Examples of Vendors observed on Las Vegas Boulevard.	28
Picture 2.8 – Back of Curb Concrete Wall and Landscape Treatment.	17	Picture 2.34 – Example of Individuals not considered for this Study as Non-Permanent Obstructions.	28
Picture 2.9 – Metal Fence Median Barrier.	17	Picture 3.1 – Assisted Walker.	31
Picture 2.10 – Concrete Median Barrier.	17	Picture 3.2 – Typical Pedestrian Activity on South end of Study Corridor.	35
Picture 2.11 – Back of Curb Cable Barrier.	17	Picture 3.3 – Typical Pedestrian Activity on North end of Study Corridor.	35
Picture 2.12 – Back of Curb Elevated Landscaping Barrier.	17	Picture 3.4 – Bellagio Fountains – Daily Attraction.	45
Picture 2.13 – South Entrance to Pedestrian Walkway through Linq Construction.	19	Picture 3.5 – Mirage Volcano – Daily Attraction.	45
Picture 2.14 – Pedestrian Walkway through Linq Construction.	19	Picture 3.6 – Sirens of Treasure Island – Daily Attraction.	45
Picture 2.15 – Pedestrian Bridge Detour at Harmon Center from Cosmopolitan Hotel/Casino.	19	Picture 3.7 – Pedestrian Activity at New York-New York Holiday Saturday.	46
Picture 2.16 – Caesars Linq Construction.	20	Picture 3.8 – Pedestrian Activity at Venetian Hotel/Casino Holiday Saturday.	46
Picture 2.17 – Bus Turnout Construction at Harrah’s Hotel/Casino.	20	Picture 3.9 – Pedestrian Activity at Bellagio Hotel/Casino South Typical Saturday.	46
Picture 2.18 – Venetian Hotel/Casino Walkway Construction.	20	Picture 3.10 – Flamingo Road West Pedestrian Bridge on Holiday Saturday.	62
Picture 2.19 – Building/Signage Modifications at Harmon Center.	20	Picture 3.11 – Flamingo Road East Pedestrian Bridge Escalators.	62
Picture 2.20 – MGM Grand Hotel/Casino Renovation Detour.	20	Picture 3.12 – Caesars Linq Construction Zone which Experienced Walking Speed LOS F.	81
Picture 2.21 – Landscaping/Utility Construction at the Flamingo Hotel/Casino.	20	Picture 3.13 – Typical Pedestrian Bridge.	88
Picture 2.22 – Activity Level on Memorial Day Weekend.	21	Picture 3.14 – Flamingo Road West Pedestrian Bridge.	88
Picture 2.23 – Clark County Camera at Treasure Island Hotel/Casino.	23	Picture 3.15 – Non-Permanent Obstructions (vendors) on Pedestrian Bridge – Flamingo Road East.	98
Picture 2.24 – Manual Counter on Pedestrian Bridge.	24	Picture 3.16 – Non-Permanent Obstructions (solicitor/vendor) on Pedestrian Bridge – Tropicana Avenue West.	98
		Picture 3.17 – Type 2 Bus Stop – In Front of Walkway.	101
		Picture 3.18 – Type 3 Bus Stop – Behind Walkway.	101



Picture 3.19 – Pedestrian Activity between Mirage and TI after Volcano Show and before Siren Show.	107
Picture 4.1 – Stairway Queue due to Non-Functional Escalators.....	137
Picture 4.2 – Bus Patron in Street Looking for Arriving Bus.....	138
Picture 4.3 – Stairwell at Harmon East Pedestrian Bridge.	138
Picture 4.4 – Pedestrians in Street at McDonalds.	138
Picture 4.5 – Fashion Show Mall Boulevard Access – No Pedestrian Containment.....	138
Picture 4.6 – Pedestrians in Street in front of Fashion Show Mall.	138
Picture 4.7 – Location A at 8 Motel Mart.	139
Picture 4.8 – Location B near Hard Rock Cafe at MGM Drive.	139
Picture 4.9 – Location C at Harley Davidson Cafe near Harmon Avenue.	139
Picture 4.10 – Location D – “Pork chop” Refuge Island near Bellagio Hotel/Casino.	141
Picture 4.11 – Location E at North end of Planet Hollywood Hotel/Casino.	141
Picture 4.12 – Location F in front of Margaritaville.....	141
Picture 4.13 – Location G near Caesars Palace Hotel/Casino.	142
Picture 4.14 – Location H in front of Harrah’s Hotel/Casino.....	142
Picture 4.15 – Location I at Casino Royale Driveway.	142
Picture 4.16 – Location J at Treasure Island Bus Stop.....	143

LIST OF FIGURES

Figure 1.1 – Study Corridor	1
Figure 1.2 – 2010 Highway Capacity Manual Standards for Pedestrian Geometry	2
Figure 1.3 – Level of Service Visual Comparison – Literature and Las Vegas Boulevard	2
Figure 1.4 – Effective Walkway Width with Fixed Obstacles	4
Figure 1.5 – Pedestrian Volume Trends Observed at the Imperial Palace Hotel/Casino.....	7
Figure 2.1 – Typical Effective Walkway Width (W_E) per Segment	9
Figure 2.2 – Newsrack Locations.....	11
Figure 2.3 – Type 1 (Isolated) Bus Stop Example	12
Figure 2.4 – Type 2 (Front of Walk) Bus Stop Example	12

Figure 2.5 – Type 3 (Behind Walk) Bus Stop Example.....	12
Figure 2.6 – Bus Stops along Las Vegas Boulevard – Russell Road to Sahara Avenue	13
Figure 2.7 – 2010 Average Annual Daily Traffic (AADT) - Vehicles.....	15
Figure 2.8 – Pedestrian Crash Severity October 2008 to September 2011	16
Figure 2.9 – Pedestrian Containment Locations.....	18
Figure 2.10 – Pedestrian Volume Count Locations	22
Figure 2.11 – Walking Speed Data Collection Worksheet	25
Figure 2.12 – Walking Speed Segment Map	26
Figure 2.13 – Effective Walkway Width (W_E) Diagram	29
Figure 3.1 – Pedestrian Volume – Max 15-Minutes May, 26 2012.....	32
Figure 3.2 – Pedestrian Volume – Max 15-Minutes June, 16 2012.....	33
Figure 3.3 – Pedestrian Volume Trend Comparison.....	34
Figure 3.4 – Luxor Hotel/Casino (1) – Pedestrian Volume by Time	36
Figure 3.5 – Tropicana Hotel/Casino (M1) – Pedestrian Volume by Time	37
Figure 3.6 – Excalibur Hotel/Casino (M2) – Pedestrian Volume by Time	38
Figure 3.7 – Wynn Hotel/Casino (18) – Pedestrian Volume by Time	39
Figure 3.8 – North of Fashion Show Drive (M8) – Pedestrian Volume by Time	40
Figure 3.9 – Riviera Hotel/Casino (20) – Pedestrian Volume by Time.....	41
Figure 3.10 – Circus Circus Hotel/Casino (21) – Pedestrian Volume by Time	42
Figure 3.11 – Fontainebleau Hotel/Casino (M9) – Pedestrian Volume by Time	43
Figure 3.12 – Hilton Grand Vacations (M10) – Pedestrian Volume by Time	44
Figure 3.13 – New York-New York Hotel/Casino (CC1) – Pedestrian Volume by Time.....	47
Figure 3.14 – MGM Grand Hotel/Casino (5) – Pedestrian Volume by Time	48
Figure 3.15 – City Center – Crystals (6) – Pedestrian Volume by Time.....	49
Figure 3.16 – Harley Davidson Cafe (Metro1) – Pedestrian Volume by Time.....	50
Figure 3.17 – Bellagio Hotel/Casino South (CC2) – Pedestrian Volume by Time.....	51
Figure 3.18 – Paris Hotel/Casino (M5) – Pedestrian Volume by Time	52
Figure 3.19 – Bally’s Hotel/Casino (9) – Pedestrian Volume by Time	53

Figure 3.20 – Bellagio Hotel/Casino (11A) – Pedestrian Volume by Time.....	54	Figure 3.48 – Average Pedestrian Walking Speed per Segment (June 16, 2012).....	87
Figure 3.21 – Flamingo Hotel/Casino (12) – Pedestrian Volume by Time.....	55	Figure 3.49 – Observed Pedestrian Bridge Walking Speeds – Holiday Saturday.....	89
Figure 3.22 – Caesars Palace Hotel/Casino (M6) – Pedestrian Volume by Time.....	56	Figure 3.50 – Observed Pedestrian Bridge Walking Speeds – Typical Saturday.....	90
Figure 3.23 – Forum Shops (13) – Pedestrian Volume by Time.....	57	Figure 3.51 – Average Non-Permanent Obstructions per Segment (May 26, 2012).....	92
Figure 3.24 – Harrah’s Hotel/Casino (14) – Pedestrian Volume by Time.....	58	Figure 3.52 – Average Non-Permanent Obstructions per Segment (June 16, 2012).....	93
Figure 3.25 – Mirage Hotel/Casino (15) – Pedestrian Volume by Time.....	59	Figure 3.53 – East “Strip” Non-Permanent Obstructions by Segment (May 26, 2012).....	94
Figure 3.26 – Venetian Hotel/Casino (CC3) – Pedestrian Volume by Time.....	60	Figure 3.54 – West “Strip” Non-Permanent Obstructions by Segment (May 26, 2012).....	95
Figure 3.27 – Treasure Island Hotel/Casino (CC4) – Pedestrian Volume by Time.....	61	Figure 3.55 – East “Strip” Non-Permanent Obstructions by Segment (June 16, 2012).....	96
Figure 3.28 – Tropicana Avenue South Pedestrian Bridge (M3) – Pedestrian Volume by Time.....	63	Figure 3.56 – West “Strip” Non-Permanent Obstructions by Segment (June 16, 2012).....	97
Figure 3.29 – Tropicana Avenue West Pedestrian Bridge (2) – Pedestrian Volume by Time.....	64	Figure 3.57 – Non-Permanent Obstructions by Pedestrian Bridge (May 26, 2012).....	99
Figure 3.30 – Tropicana Avenue East Pedestrian Bridge (3) – Pedestrian Volume by Time.....	65	Figure 3.58 – Non-Permanent Obstructions by Pedestrian Bridge (June 16, 2012).....	100
Figure 3.31 – Tropicana Avenue North Pedestrian Bridge (4) – Pedestrian Volume by Time.....	66	Figure 3.59 – Max Peak 15-Minute Boardings (May 26, 2012).....	102
Figure 3.32 – Harmon Avenue West Pedestrian Bridge (7) – Pedestrian Volume by Time.....	67	Figure 3.60 – Max Peak 15-Minute Boardings (June 16, 2012).....	103
Figure 3.33 – Harmon Avenue North Pedestrian Bridge (M4) – Pedestrian Volume by Time.....	68	Figure 3.61 – Pedestrian Obstruction Sizes.....	104
Figure 3.34 – Flamingo Road South Pedestrian Bridge (8) – Pedestrian Volume by Time.....	69	Figure 3.62 – Model 1 – Pedestrian Bridge.....	105
Figure 3.35 – Flamingo Road East Pedestrian Bridge (10) – Pedestrian Volume by Time.....	70	Figure 3.63 – Model 2 – Sidewalk.....	106
Figure 3.36 – Flamingo Road West Pedestrian Bridge (11) – Pedestrian Volume by Time.....	71	Figure 3.64 – Model 3 – Sidewalk and Bus Stop.....	108
Figure 3.37 – Flamingo Road North Pedestrian Bridge (Metro2) – Pedestrian Volume by Time.....	72	Figure 3.65 – Model 4 – Queuing at Signalized Intersection.....	109
Figure 3.38 – Venetian Pedestrian Bridge (16) – Pedestrian Volume by Time.....	73	Figure 3.66 – Model 1 – Pedestrian Bridge Model Screenshot.....	111
Figure 3.39 – Spring Mountain Road West Pedestrian Bridge (M7) – Pedestrian Volume by Time.....	74	Figure 3.67 – Model 2 – Sidewalk Model Screenshot.....	111
Figure 3.40 – Spring Mountain Road East Pedestrian Bridge (17) – Pedestrian Volume by Time.....	75	Figure 3.68 – Model 3 – Sidewalk and Bus Stop Model Screenshot.....	112
Figure 3.41 – Wynn Pedestrian Bridge (19) – Pedestrian Volume by Time.....	76	Figure 3.69 – Model 4 – Queuing at Signalized Intersection Model Screenshot.....	112
Figure 3.42 – Pedestrian Volume Level of Service on Las Vegas Boulevard.....	78	Figure 3.70 – Model 1 – Pedestrian Bridge Model Output.....	113
Figure 3.43 – East “Strip” Walking Speeds Holiday Saturday (May 26, 2012).....	82	Figure 3.71 – Model 2 – Sidewalk Model Output.....	113
Figure 3.44 – West “Strip” Walking Speeds Holiday Saturday (May 26, 2012).....	83	Figure 3.72 – Model 3 – Sidewalk and Bus Stop Model Output.....	114
Figure 3.45 – East “Strip” Walking Speeds Typical Saturday (June 16, 2012).....	84	Figure 3.73 – Walkway Segments that Exceed LOS C.....	116
Figure 3.46 – West “Strip” Walking Speeds Typical Saturday (June 16, 2012).....	85	Figure 3.74 – Pedestrian Volume Level of Service on Las Vegas Boulevard.....	117
Figure 3.47 – Average Pedestrian Walking Speed per Segment (May 26, 2012).....	86	Figure 3.75 – Harley Davidson Cafe (R3) – Pedestrian Volume by Time.....	118

Figure 3.76 – Harmon Avenue West Pedestrian Bridge (R4) – Pedestrian Volume by Time 119

Figure 3.77 – Cosmopolitan Hotel/Casino (R5) – Pedestrian Volume by Time..... 120

Figure 3.78 – Bally’s Hotel/Casino South (R6) – Pedestrian Volume by Time..... 121

Figure 3.79 – Flamingo Road West Pedestrian Bridge (R7) – Pedestrian Volume by Time..... 122

Figure 3.80 – Flamingo Hotel/Casino (R9) – Pedestrian Volume by Time..... 123

Figure 3.81 – Caesars Palace Coliseum (R10) – Pedestrian Volume by Time 124

Figure 3.82 – Forum Shops (R11) – Pedestrian Volume by Time..... 125

Figure 3.83 – Harrah’s Hotel/Casino (R12) – Pedestrian Volume by Time 126

Figure 3.84 – Casino Royale Hotel/Casino (R13) – Pedestrian Volume by Time 127

Figure 3.85 – Venetian Hotel/Casino North (R15) – Pedestrian Volume by Time 128

Figure 3.86 – Treasure Island Bus Stop (R16) – Pedestrian Volume by Time 129

Figure 3.87 – Treasure Island Hotel/Casino (R17) – Pedestrian Volume by Time 130

Figure 3.88 – Harley Davidson Cafe (R3) – Pedestrian Volume by Time – Non-Holiday 131

Figure 3.89 – Caesars Palace Coliseum (R10) – Pedestrian Volume by Time – Non-Holiday 132

Figure 3.90 – Casino Royale Hotel/Casino (R13) – Pedestrian Volume by Time – Non-Holiday 133

Figure 3.91 – Treasure Island Hotel/Casino (R16) – Pedestrian Volume by Time – Non-Holiday 134

Figure 4.1 – Saw-tooth Walkway that Encourages Walking in Street 138

Figure 4.2 – Locations of Pedestrian Movement Concern 140

LIST OF EXHIBITS

Exhibit A – Right-of-Way/Pedestrian Easement Exhibits

Exhibit B – Updated No Obstructive Use Drawings

Exhibit C – Clark County Municipal Code Chapter 16.11 – Obstructive Uses of Public Sidewalks

1 INTRODUCTION

As one of the recommendations of the Resort Corridor Workgroup, this study was prepared for Clark County Department of Public Works to document pedestrian activity on Las Vegas Boulevard (the “Strip”) between Russell Road and Sahara Avenue. In an effort to improve the pedestrian experience, this study expands upon the findings and recommendations of the 1994 Lee Engineering report *Las Vegas Boulevard South Pedestrian Walkway Study* which helped enhance the walking environment of the “Strip” for the past 18 years. For this study, pedestrian volume data was collected over Memorial Day Weekend (May 26, 2012), one of the busiest Saturdays on Las Vegas Boulevard, and on a typical summer Saturday (June 16, 2012) to capture and evaluate peak and typical pedestrian conditions. Pedestrian volumes and walking speeds were documented for comparison with calculated walkway capacity. Non-permanent obstructions were also located, quantified and classified to identify possible impediments to pedestrian movement.

1.1 Study Purpose

The unobstructed movement of pedestrians along Las Vegas Boulevard is important in maintaining the economic vitality of Las Vegas. The purpose of the study is to identify locations and time periods of pedestrian congestion along Las Vegas Boulevard (the “Strip”) to aid in the enforcement of the County’s Obstructive Use Ordinance.

1.2 Study Goals

The goals of the study are to identify locations of pedestrian walkway congestion by time of day and day of week (including holidays) for use in the enforcement of and/or revisions to County Code 16.11-Obstructive Uses of Public Sidewalks. The study also updates the existing No Obstruction Zones based on the current conditions on Las Vegas Boulevard, congestion locations, mid-block crosswalks, intersections and driveways.

1.3 Study Corridor

The study corridor includes 4.2 miles of Las Vegas Boulevard from Russell Road to Sahara Avenue within the Las Vegas Valley. The corridor (Figure 1.1) is located east of Interstate 15, south of US Highway 95 and north of Interstate 215 in Clark County, Nevada. The study corridor provides pedestrian access to some 30 major casino/resorts and 3 major retail centers.

The pedestrian activity within the study corridor of Las Vegas Boulevard is primarily driven by the gaming and related tourist industry which is a major source of revenue for Clark County. In 2011 gaming revenue totaled \$6.1 Billion according to the Las Vegas Convention and Visitors Authority (LVCVA).

Increases in Las Vegas Boulevard pedestrian activity can be associated with the growth in the number of hotel rooms and the number of visitors to Las Vegas. In 2001, the number of rooms in Clark County totaled 126,610 and the number of visitors was estimated at 35,017,317.

By 2011, the number of rooms in Clark County totaled 150,161 and the number of visitors was estimated at 38,928,708. The room inventory and number of visitors is expected to continue to increase with casino/resort expansions, new resort construction, and timeshare construction.

As of 2011, Las Vegas had the highest inventory of hotel rooms (150,161) out of any other city in the United States. In addition, the seventeen largest hotels in the United States are located within the study corridor. There were 41 casinos located on Las Vegas Boulevard with gross gaming revenue of at least \$1 Million in 2011.

Conventions, trade shows, and meetings also contribute to pedestrian activity along the Las Vegas Boulevard. These functions draw nearly 5 million attendees annually to Las Vegas, or about 12% of all visitors during 2011. They have contributed billions of dollars in non-gaming revenue to the economy.

On any given day, approximately 106,500 people visit the Las Vegas Valley. Many of these are pedestrians on the “Strip” during their visit. According to the December 31, 2011 Las Vegas Visitor Profile Summary, these visitors and potential Las Vegas Boulevard pedestrians have the following characteristics: 84% are repeat visitors; there is an average of 2.1 adults in each party; 10% of the visitors brought children; and, visiting parties stayed an average of 3.7 nights. In addition, according to the Las Vegas Convention and Visitors Authority 4th Quarter 2011 Summary Marketing Bulletin, 57% of all visitors came for vacation, pleasure or gambling, 16% for business/convention, and 27% for other reasons. The average expenditures per visitor for food and drink, shopping, shows, and sightseeing were approximately \$526. Seventy-seven percent of all visitors gambled with an average gambling budget of approximately \$447.

1.4 Literature Review

Las Vegas Boulevard (the “Strip”) is a unique worldwide tourist destination. Research from other locations cannot be directly applied to this pedestrian environment. This section presents a review of relevant technical literature as it applies to this one-of-a-kind pedestrian environment and applicable background pedestrian literature for Las Vegas Boulevard.

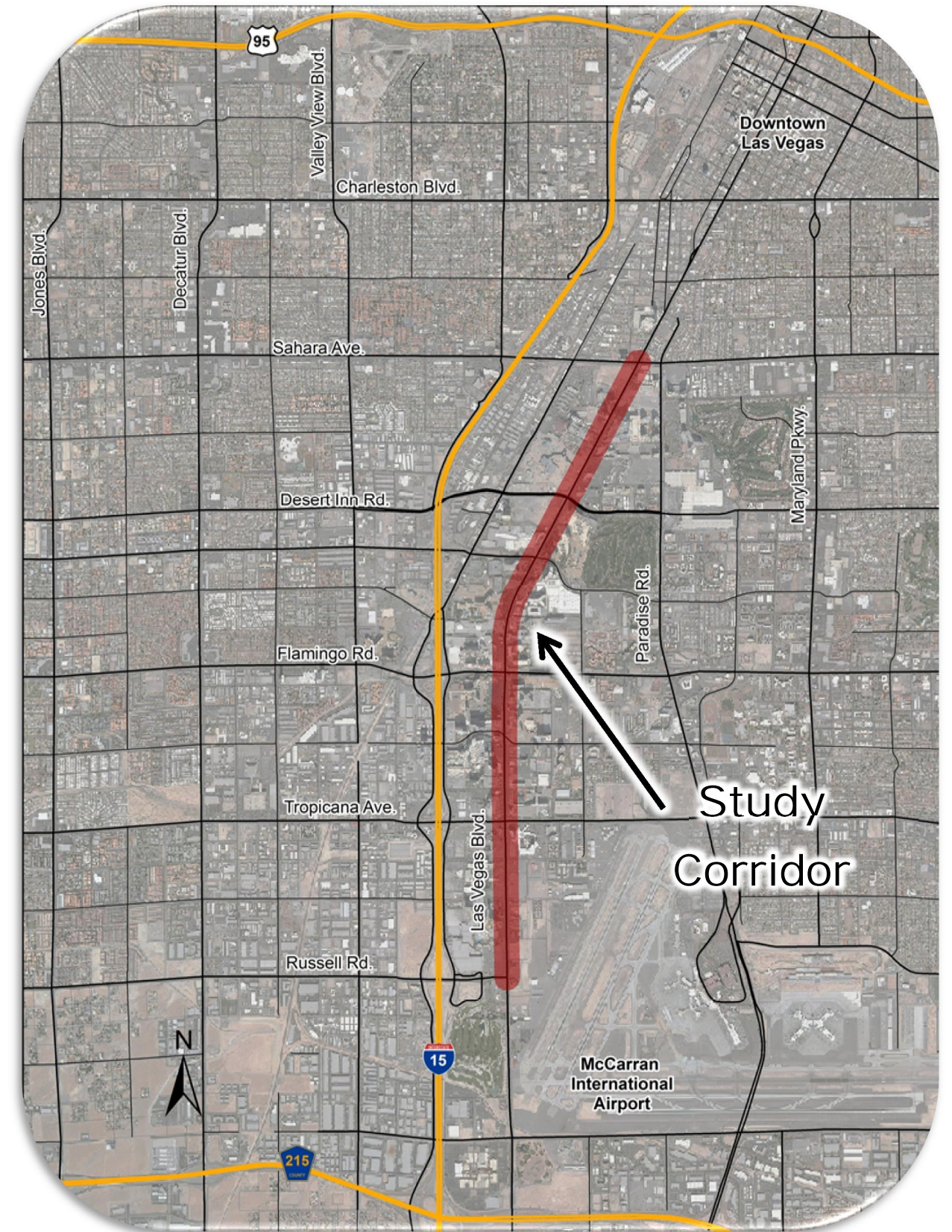

Figure 1.1 – Study Corridor

1.4.1 Technical Literature

Technical engineering literature was reviewed and relevant literature was identified and summarized from the 1985 and 2010 editions of the Highway Capacity Manual (HCM) as well as other respected research on pedestrian movement.

Pedestrian Planning and Design – Fruin 1971

Pedestrian Planning and Design by Dr. John J. Fruin is one of the first publications to describe and quantify the space people need to walk and queue (stand in line). In this publication, Fruin introduced the concept of the body ellipse to define personal comfort zones of the individual.

His work also defined pedestrian flow volume for a walkway as the number of pedestrians per foot of walkway width per minute. The pedestrian flow volume was then used by Fruin to define walkway level of service by letter grade representing the freedom of walkway mobility. Another key factor in determining walkway conditions was to recognize that the “effective walkway” width is reduced from the total walkway width by the constricting effects of street impediments such as light standards, fire hydrants and refuse enclosures. The pedestrian walkway and queuing concepts identified by Fruin are the fundamental evaluation concepts used in this study.

To illustrate the concepts of LOS in relation to pedestrian volume and walkway width (W), Figure 1.3 was created pairing figures from *Pedestrian Planning and Design* by Fruin and pictures from the “Strip” during the data collection period. This visualization demonstrates the perception of level of service accompanied by the required square footage per person for each level. According to Fruin, at LOS D “the majority of persons would have their normal walking speeds restricted and reduced” and for LOS A thru C only minor conflicts exist. LOS E and F cause adjustment to walking gait, suggesting that the majority of the pedestrians would have to shuffle their feet to progress forward. At these levels of service contact with others is

frequent and forward progress is solely determined by those upstream of the pedestrian traffic flow.

Highway Capacity Manual (HCM)

A significant amount of the research portrayed in the 1985 HCM and its most recent 2010 edition in regards to pedestrians and walkway level of service originated in the work of Dr. Fruin. The concept of the body ellipse defines the average male human body as an 18” depth and a 24” shoulder breadth, necessitating 3.0 square feet standing still (i.e., in a queue for a bus). The 2010 HCM also defined the pedestrian body ellipse which is shown in Figure 1.2 as adapted from the 2010 HCM.

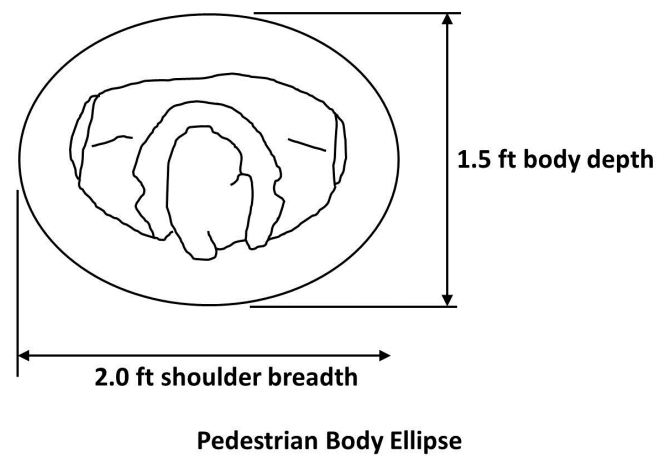

Figure 1.2 – 2010 Highway Capacity Manual Standards for Pedestrian Geometry



Picture 1.1 – Pedestrian Activity Level (Memorial Day Weekend 2012).



Source: Adapted from Fruin 1971.

Figure 1.3 – Level of Service Visual Comparison – Literature and Las Vegas Boulevard

Accounting for the body ellipse, the HCM defines pedestrians queuing LOS at seven square feet per person to provide a LOS C. Reducing the queue space down to three square feet per person provides a LOS D.

Level of service (LOS) is calculated differently for queued pedestrians versus walking pedestrians (where a walking space requirement is needed). The 2010 HCM has adopted two walking LOS scales, one determined by walking speed and the other by pedestrian flow rate.

Walking Speed LOS

Walking speeds in the 2010 HCM are developed from two studies that Fruin conducted identifying the average free-flow walking speed to be typically exceeding 145 feet per minute (or 2.4 ft/sec); speeds below that level should be considered restricted, causing “irregular human locomotion.” Fruin’s research found that the average walking speed varied between 3.5 and 4.5 ft/sec depending on the age of the pedestrian.

The 1985 HCM included, for the first time, in the manual a methodology for analyzing pedestrian level of service for walkways recognizing that “speed is an important level-of-service criterion because it can be easily observed and measured, and because it is a descriptor of the service pedestrians perceive.” The 1985 HCM included the following statement regarding pedestrian walking speed and perceived service:

“The analysis of pedestrian flow is generally based on *mean* or average, walking speeds of groups of pedestrians. Within any group, or among groups, there can be considerable differences in flow characteristics due to trip purpose, land use, type of group, age and other factors. Pedestrians going to and from work, using the same facilities day after day, exhibit higher walking speeds than shoppers [based on research conducted by Pushkarev and Zupan in 1975]. Older or very young persons will tend to walk at a slower gait than other groups. Shoppers not only tend to walk slower than commuters, but may decrease the effective walkway width by stopping to window shop. Thus in applying the techniques and numerical data the analyst should adjust pedestrian behavior which deviates from the regular pattern represented in the basic speed, volume and density curves” (HCM, 1985 pg. 13-6) (also included in HCM, 2010 pg. 4-29).

The above paragraph suggests that direct application of the LOS chart provided in the manual may not yield representative results and that a LOS C may not be the same for commuters as compared to tourists.

In describing the current pedestrian mode of travel, the current 2010 HCM makes a similar acknowledgement to walking speed as its preceding editions:

“Pedestrian walking speed is highly dependent on the characteristics of the walking population. The proportion of

elderly pedestrians, and children in the population, as well as trip purpose, affect walking speed” (HCM, 2010 pg. 4-24).

The 2010 HCM also suggests that a default free-flow speed (i.e. an average pedestrian’s speed on an otherwise empty sidewalk) of 5.0 ft/sec is appropriate based on average walking speeds. It should be noted that the 2009 Edition of the “Manual on Uniform Traffic Control Devices for Streets and Highways” (MUTCD) has a recommended 3.5 ft/sec pedestrian walking speed to cross a street or highway, which is a decrease in walking speed of 4.0 ft/sec in previous editions. This slower walking speed is based on research conducted by the Transit Cooperative Research Program (TCRP), the National Cooperative Highway Research Program (NCHRP) and the Texas Transportation Institute (TTI). The LOS criteria included in the 2010 HCM equates a LOS rating of “C” to a minimum average walking speed of 4.0 ft/sec. If the MUTCD value of 3.5 ft/sec were used the corresponding LOS would be “E”. This difference identifies the need for a more comprehensive study of existing walking speeds of Las Vegas Boulevard to document the average walking speed of a Las Vegas tourist. While flow rate, average space and volume/capacity ratios are used as LOS criterion in the 2010 HCM, average pedestrian speed is a reasonable measure of the service that pedestrians are receiving from a particular walkway.

The 2010 HCM suggests that generally a pedestrian speed of 4.0 ft/s or faster is considered desirable and a speed of 2.0 ft/s or less is considered undesirable. Again it should be noted that this “desirability” is generalized from national studies. These studies may or may not be representative of the pedestrians on Las Vegas Boulevard.

Table 1.1 displays the LOS criteria based on walking speed from the 2010 HCM.

Table 1.1 – Walking Speed LOS from 2010 HCM

LOS	Average Speed (ft/s)	Comments
A	>4.25	Ability to move in desired path, no need to alter movements
B	>4.17 - 4.25	Occasional need to adjust path to avoid conflicts
C	>4.00 - 4.17	Frequent need to adjust path to avoid conflicts
D	>3.75 - 4.00	Speed and ability to pass slower pedestrians restricted
E	>2.50 - 3.75	Speed restricted, very limited ability to pass slower pedestrians
F	≤2.50	Speeds severely restricted, frequent contact with other users

Pedestrian Volume/Flow Rate LOS

The 1985 HCM recommended an equation for finding pedestrian flow rate as:

$$v = \frac{V_{p15}}{15W_E}$$

where: v = pedestrian flow rate in ped/min/ft,

V_{p15} = peak 15-minute pedestrian count in ped/15-minute, and

W_E = effective walkway width in feet.

The 2010 HCM defines effective walkway width (W_E) as follows:

“Effective walkway width is the portion of a walkway that can be used effectively by pedestrians. Various types of obstructions and linear features... reduce the walkway area that can be effectively used by pedestrian. The effective walkway width at a given point along the walkway is computed as follows:

$$W_E = W - W_O$$

where:

W_E = effective walkway width (ft),

W or W_T = total walkway width at a given point along the walkway (ft), and

W_O = sum of fixed-point effective widths and linear-feature shy distances at a given point along walkway (ft)” (pg. 23-9, 2010 HCM).

As a reference, Figure 1.4 illustrates a portion of a sidewalk or walkway and the effective walkway width (W_E) created by fixed objects. According to the 2012 HCM:

“Linear features such as the street curb, [a] low wall, [or a] building face each have associated shy distances. The shy distance is the buffer that pedestrians give themselves to avoid accidentally stepping off the curb, brushing against a building face, or getting too close to other pedestrians standing under awnings or window shopping. Fixed objects, such as [a] tree, have effective widths associated with them. The fixed-object effective width includes the object’s physical width, any functionally unusable space (e.g., the space between a parking meter and the curb of the space in front

of a bench occupied by people’s legs and belongings), and the buffer given the object by pedestrians” (pg. 23-9, 2010 HCM).

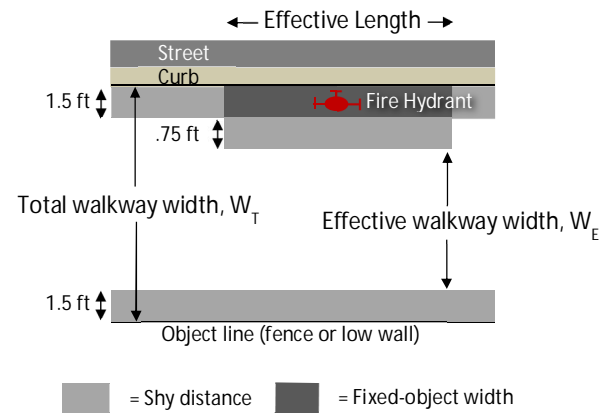

Figure 1.4 – Effective Walkway Width with Fixed Obstacles

Figure 1.4 also illustrates the effective length of a fixed object. As described by the 2010 HCM:

“the effective width of a fixed object extends over an effective length that is considerably longer than the object’s physical length. The effective length represents the portion of the walkway that is functionally unusable because pedestrians need to move to one side ahead of time to get around a fixed object. The effective length of a fixed object is assumed to be five times the object’s effective width.

“Typically, a walkway operational analysis evaluates the portion of the walkway with the narrowest effective width, since this section forms the constraint on pedestrian flow. A design analysis identifies the minimum effective walkway width that must be maintained along the length of the walkway to avoid pedestrian queuing or spillover” (pg. 23-10, 2010 HCM).

Table 1.2 summarizes the effective widths of a variety of typical fixed objects found along pedestrian facilities. The values in Table 1.2 can be used to estimate the impacts of walkway objects when specific walkway configurations are not available.

Once effective walkway widths (W_E) are established and hourly pedestrian demands are known, flow rates can be calculated and LOS determined.

The 2010 HCM recognizes that its pedestrian LOS methodology is limited in that it does not address LOS for pedestrians with disabilities, including vision or mobility impairments. Another limitation of the HCM methodology is the capacity of pedestrian facilities. Pedestrian facility capacity is based on research conducted on contained facilities where pedestrians cannot walk outside the designated walkway. Las Vegas Boulevard has many unconstrained walkway segments which allow pedestrians to step off the

walkway into the street, resulting in a safety concern. The 2010 HCM states: “to avoid pedestrian spillover, it is desirable to design a walkway to achieve LOS C or better (i.e., a maximum of 10 ped/min/ft)”.

Table 1.2 – Typical Fixed-Object Effective Widths from 2010 HCM

Fixed Object	Effective Width (ft)
Street Furniture	
Light pole	2.5-3.5
Traffic signal poles and boxes	3.0-4.0
Fire hydrants	2.5-3.0
Traffic signs	2.0-2.5
Parking meters	2.0
Trash cans (1.8 ft diameter)	3.0
Bus shelters (on sidewalk)	6.0-7.0
Landscaping	
Trees	3.0-4.0
Planter boxes	5.0

Table 1.3 defines pedestrian level of service (LOS) based on flow rate (ped/min/ft).

Table 1.3 – Flow Rate LOS from 2010 HCM

LOS	Flow Rate (p/min/ft)	Comments
A	≤5	Ability to move in desired path, no need to alter movements
B	>5 - 7	Occasional need to adjust path to avoid conflicts
C	>7 - 10	Frequent need to adjust path to avoid conflicts
D	>10 - 15	Speed and ability to pass slower pedestrians restricted
E	>15 - 23	Speed restricted, very limited ability to pass slower pedestrians
F	Variable	Speeds severely restricted, frequent contact with other users

The 2010 HCM suggests that LOS A through LOS C be typically applied to off-street pedestrian facilities based on pedestrian space, rather than for capacity conditions. Although Las Vegas Boulevard sidewalks parallel a relatively high vehicle volume street, various segments have constructed pedestrian buffers creating the atmosphere of an off-street pedestrian facility.

1.4.2 Background Literature

The pedestrian activity along Las Vegas Boulevard from Russell Road to Sahara Avenue has steadily increased over the years. Clark County conducted a study of the Resort Corridor in 1993 which was followed by an in depth pedestrian analysis of the “Strip” by Lee Engineering in 1994. The Lee study recommended specific measures be implemented by Clark County

to improve the pedestrian walkway system and pedestrian safety of Las Vegas Boulevard. Many of the study recommendations were implemented by Clark County and were included in the 1994 ordinance of Title 16 Roads and Highways Chapter 16.11 Obstructive Uses of Public Sidewalks.

Since the implementation of “No Obstruction Zones” in the 1994 ordinance, many issues relating to pedestrian movements have been voiced by resort operators, the public, and the Board of County Commissioners. In efforts to address these issues, the Resort Corridor Workgroup was formed by the Clark County Board of Commissioners to identify action items to improve pedestrian safety and the experience of Las Vegas Boulevard (the “Strip”). The following is a summary of existing literature on the “Strip”.

An Analysis of Existing Walkway Pedestrian Capacities along Las Vegas Boulevard South: Methodology, Discussion and Future Data Collection Requirements – Clark County Department of Public Works Traffic Management Division – 1993

In an attempt to quantify Las Vegas Boulevard’s ability to carry pedestrians and its peak pedestrian characteristics, Clark County conducted a pedestrian analysis from Sahara Avenue to south of what was then the Hacienda Hotel/Casino. The Hacienda Hotel/Casino has since been razed and replaced by the Mandalay Bay Resort. The study corridor was approximately four miles in length. Four locations were selected to provide a representative sample of pedestrian activity along the “Strip”:

- O’Shea’s Casino – directly south of the Imperial Palace Hotel/Casino
- Harrah’s Hotel/Casino
- Casino Royale Hotel/Casino
- El Morocco – directly south of the Riviera Hotel/Casino

Each of the pedestrian counting sites was located on the east side of Las Vegas Boulevard (the “Strip”). The distance from the southernmost data collection point to the northernmost data collection point was approximately 1.5 miles.

The study documented walkway widths along Las Vegas Boulevard to be generally 6, 7.5, 10 or 12 feet wide although many sections contained physical objects which reduced their effective width (W_E).

A total of seven observed hours of pedestrian data was collected during the first two weeks of April 1993. Three of the locations were counted on a weekday from 10:15 AM to 11:15 AM and from 3:00 PM to 4:00 PM while the fourth (O’Shea’s) was only counted from 3:00 PM to 4:00 PM. The County relied on previous pedestrian counts that were collected at the MGM Grand Hotel/Casino in April 1991 to conclude that peak pedestrian volumes occur early Saturday afternoons around 2:00 PM and late Saturday evenings, around 10:00 PM. The data from the 1991 MGM Grand Hotel/Casino study was also used to calculate conversion factors from weekday to weekend volumes. Clark County then used the adjustment factors from the 1993 weekday counts to estimate weekend peak volumes.

Clark County found that three of the four locations were “operating at unacceptable LOS’s for peak pedestrian volumes.” These three sites were all located within 0.5 miles of each other suggesting that this congestion might not be representative along the entire four miles of the “Strip”. The study recommended that unnecessary obstructions be prohibited and that the elimination of “hawkers” (hand billers) and news racks was desired. A minimum effective walkway width (W_E) of 5.0 feet was also recommended in all “high volume pedestrian areas.”

Las Vegas Boulevard South Pedestrian Walkway Study - Lee Engineering – 1994

In 1994, a pedestrian study was commissioned by the Nevada Resort Association. This study is considered to be the first comprehensive study of the Las Vegas Boulevard pedestrian walkway environment. Previous studies had been conducted, but with either a very narrow scope or a scope that was too broad. The study area extended a total of 2 ¾, miles from Circus Circus Drive/Riviera Boulevard to one quarter mile south of Tropicana Avenue. The study area included 31 resorts, two major retail properties, the Las Vegas Convention Center and other small retail businesses and motels.

The study followed the methodology described in the 1985 Highway Capacity Manual (HCM) for calculation of pedestrian level of service and included:

- Initial field investigation
- Preliminary data collection
- Pedestrian volume collection
 - Pedestrian volume data collection site selection
 - Walking observations
 - Elevated vantage point observations
- Walkway inventory
- Fixed and temporary obstruction determination
- Dynamic obstruction experiment
- Preparation of as-built drawings
- LOS calculations

Pedestrian volume data was recorded at seven data collection sites (including a total of 31 data collection points) between the hours of 10:00 AM to 1:30 AM January 6 through January 9 (Thursday – Sunday). The data collection was scheduled to coincide with the Consumer Electronics Show in an attempt to analyze the peak pedestrian conditions. Three video cameras were used for the data collection and progressively moved from location to location to obtain representative samples of each data collection site. A total of 33 hours of video data was collected which resulted in over 50 hours of individual pedestrian sidewalk cross section observations.

To reduce and summarize the video data, a computer program was written and used to count and classify the number of pedestrians in 30-second intervals using the following categories:

- Pedestrians on walkway;
- Pedestrians pushing a stroller;
- Wheelchairs;
- Bicycles on walkway;

- Pedestrians in the street;
- Pedestrians off walkway; and
- Other (pedestrians on crutches, pedestrian pushing a grocery cart, skateboarder, etc.)

Although the 1985 HCM uses a 15-minute analysis period, this 1994 study analyzed LOS using a 30-second interval. The 1985 HCM equation for pedestrian flow is:

$$v = \frac{V_{p15}}{15W_E}$$

where: v = pedestrian flow rate in ped/min/ft,
 V_{p15} = peak 15-minute pedestrian count in ped/15-minute, and
 W_E = effective walkway width in feet.

The 1994 study used the following modified flow rate calculation:

$$v = \frac{2 * V}{W_E}$$

where : v = pedestrian flow rate in ped/min/ft,
 V = sum of all pedestrians counted during that 30-second interval, and
 W_E = effective walkway width in feet.

The 1985 HCM summarizes level of service (LOS) assignments based on flow rate (ped/min/ft) and other variables in Table 1.4.

Table 1.4 – Pedestrian Level of Service from 1985 Highway Capacity Manual

Level of Service	Space (sq ft/ped)	Expected Flows and Speeds		
		Ave Speed, S (ft/min)	Flow Rate, v (ped/min/ft)	Vol/Cap Ratio, v/c
A	≥ 130	≥ 260	≤ 2	≤ 0.08
B	≥ 40	≥ 250	≤ 7	≤ 0.28
C	≥ 24	≥ 240	≤ 10	≤ 0.40
D	≥ 15	≥ 225	≤ 15	≤ 0.60
E	≥ 6	≥ 150	≤ 25	≤ 1.00
F	< 6	< 150	----Variable----	

The study showed considerable variation in pedestrian flow rates between 0.0 and 29.3 ped/min/ft. A major finding of the study was that pedestrians are likely to leave the defined walkway where flow rates reach 8 ped/min/ft, which equates to a LOS C. This is less than the 2010 HCM pedestrian flow rate maximum of 10 ped/min/ft to avoid spillover (the LOS D threshold).

The Lee Engineering study also noted that the heaviest observed pedestrian volumes were seen between the Treasure Island Hotel/Casino and the Mirage Hotel/Casino following the Buccaneer Bay show, which has since been converted to the Siren show.

The study recommended no-obstruction zones for the pedestrian walkways along Las Vegas Boulevard as written into Chapter 16.11 of the Clark County Code, including the use of no-obstruction zones at intersection, mid-block crosswalks and driveway entrances. Lee Engineering made the recommendation that maintaining these areas free from obstructions increases the ability of drivers to see pedestrians and properly judge walking speeds. With increased visibility of pedestrians by drivers, public safety on the sidewalks is enhanced.

Lee Engineering also recommended an effective walkway width (W_E) of ten feet minimum for new construction along Las Vegas Boulevard to allow for sufficient walkway width (W) to accommodate future pedestrian loads. This recommendation has been adopted by Clark County and has become a condition of development for all new casino and resort development along Las Vegas Boulevard.

Obstructive Uses of Public Sidewalks – Chapter 16.11 – Clark County, Nevada, Code of Ordinances

Clark County adopted an ordinance in 1994 within their municipal code that stated that “the existing pedestrian environment is inadequate as a transportation system and lacking in many safety features.” The ordinance goes on to say that “a great number of persons are engaged in uses of the public sidewalks which create undue obstruction, hindrance, blockage, hampering, and interference with pedestrian travel.” The ordinance recognizes that when public sidewalks become congested, large numbers of pedestrians are walking in the streets (Ord. 1617 § 1 (part), 1994). It also noted that traffic signal indications were at times being ignored by pedestrians during periods of heavy pedestrian congestion, increasing pedestrian and vehicle conflicts. The ordinance identified specific uses that were permitted to obstruct the public sidewalk such as street signs, traffic signals, fire hydrants, construction equipment with permit, and any “construction, modification, addition or attraction abutting private property occurring or in place before May 1, 1994.” Obstructive uses are not permitted if the use either “causes the LOS for the sidewalk to decline below LOS C; or result in a significant threat to or degradation of the safety of pedestrians.”

Warning signs are required under the ordinance to be posted at least every quarter mile along Las Vegas Boulevard stating “RESORT DISTRICT: NO OBSTRUCTIVE USES PERMITTED ON PUBLIC SIDEWALKS AT LOCATIONS DESIGNATED BY A WHITE STRIPE, PURSUANT TO CLARK COUNTY CODE CHAPTER 16.11” (see Picture 1.2).





Picture 1.2 – Existing Ordinance Sign on Las Vegas Boulevard.

Following the recommendations of the Lee Engineering Pedestrian Study, obstructive use zones are also clearly defined within the ordinance in order to enhance safety at the following locations:

- In or within 150 feet of any mid-block crosswalk, as measured from the crosswalk parallel to the sidewalk curb toward the direction of approaching vehicular traffic;
- In or within 50 feet of any mid-block crosswalk as measured from the crosswalk parallel to the sidewalk curb away from the direction of approaching vehicular traffic;
- In or within 100 feet of any crosswalk located at an intersection of streets or highways, as measured parallel to the sidewalk curb in the direction of approaching vehicular traffic from the point of curvature of the curb or the marked edge of the crosswalk, whichever is less;
- In or within 50 feet of any crosswalk located at an intersection of streets or highways, as measured parallel to the sidewalk curb away from the direction of approaching vehicular traffic from the point of curvature of the curb or the marked edge of the crosswalk, whichever is less;
- In or within 50 feet of any driveway providing ingress into or egress from any private or non-public property, as measured parallel to the sidewalk curb outward from the point of the curb cut; and
- On or within any section of the public sidewalk which has been determined to have an average LOS of C or below, during the hours at which LOS declines below LOS C, as determined by a traffic study conducted by a registered professional engineer of the Clark County department of public works according to the methodology set forth in the Las Vegas Boulevard South Pedestrian Walkway Study.

The designation of the “No Obstruction Zones” is delineated with a white painted line on the public sidewalk. The painted line locations are identified on a map adopted by the Board of County Commissioners. Section

16.11.050 of the ordinance clearly states that “pavement markings on the public sidewalk or signs designating the limits of the “No Obstruction” zone, or plaques, monuments or medallions placed in the public sidewalk marking areas deemed to be no obstruction zones on the basis of level of service (LOS), as set forth in Section 16.11.020 shall also specify the hours during which the area is a no obstruction zone.” The affixed penalty for violation according to the ordinance was a term not to exceed six months in county jail or a fine not to exceed \$1,000, or both. A full text copy of the ordinance is provided in Exhibit C.

Resort Corridor Workgroup

Under the direction of the Clark County Board of Commissioners, the Resort Corridor Workgroup was established in August 2011 to discuss and address issues along Las Vegas Boulevard from Sahara Avenue to Russell Road. This workgroup consists of executives from the gaming community, representatives from the Las Vegas Metropolitan Police Department, the Nevada Resort Authority, and Clark County. Recommendations to enhance the pedestrian experience and safety were developed by the workgroup and presented to the Clark County Board of Commissioners for their consideration in April 2012. In relation to this study the workgroup recommended:

- The County should amend existing county code or adopt a new ordinance that restricts activities on the public sidewalks of the Resort Corridor that pose a potential risk to the safety of pedestrians. The ordinance might address the following issues, with exceptions for special events or permitted activities:
 - The use of unicycles, bicycles and other types of cycles, skateboards, roller skates, in-line skates, hula hoops larger than 4 feet in diameter and shopping carts.
 - The launching or throwing of projectiles or other objects into or through the air.
 - The use of items or engaging in actions that pose a potential risk to pedestrians (to be more specifically defined in the ordinance).
- In order to provide for pedestrian safety and to eliminate pedestrian congestion, each Resort Property is encouraged to work with the County to clarify the boundaries between public and private sidewalks.
- With respect to the provisions of Clark County Code Chapter 16.11 on obstructive uses of public sidewalks, the County should:
 - Revisit the criteria for the current designations of “no obstruction zones” and renew the enforcement of the “no obstruction zones” that still meet the criteria.
 - Review the provisions of Chapter 16.11 including contracting for a new pedestrian study.
 - Following the completion of a new pedestrian study, update the zones and amend provisions of Chapter 16.11 as necessary.
 - Amend the relevant provisions of Chapter 16.11 to clarify that pedestrian bridges are for the prompt and safe movement of pedestrians and that, like crosswalks, stopping and standing on pedestrian bridges are prohibited.

- After completion of the new pedestrian study provided for in the recommendation above, the County should consider adopting an ordinance that establishes time, place and manner restrictions on First Amendment activities on public sidewalks along the Resort Corridor that would promote public safety, welfare and other legally protected interests to the County.

Previous Las Vegas Boulevard Pedestrian Studies

With the planning of pedestrian bridges and County requirements for site development traffic impact studies to evaluate existing and future sidewalks with new construction, numerous pedestrian counts have been conducted along Las Vegas Boulevard. Table 1.5 is a partial summary of past pedestrian volume counts conducted along Las Vegas Boulevard.

Table 1.5 – Pedestrian Counts along Las Vegas Boulevard

Date	Location	15-minute Peak Volume
May 1997	New York-New York	605
July 2003	Tropicana	78
August 2007	Hilton Grand	119
March 2006	Paris	1,088
May 2007	Sahara	162
September 2007	CityCenter	866
April 2009	Showcase Mall	984
September 2011	Imperial Palace	1,027

2010 Caesars International Pedestrian Study

One of the most comprehensive efforts to observe pedestrians along Las Vegas Boulevard was conducted by Caesars International. The data from this private counting program was released to the County for use in this study. Pedestrian activity was counted from a video camera in front of the Imperial Palace Hotel/Casino from December 2009 through November 2010. Nearly 5,000,000 pedestrians were observed during a sampling of 90 count days. The pedestrian count summary contained the following relevant conclusions:

- Saturdays and Sundays experienced the highest pedestrian volumes, averaging 67,246 and 60,112 pedestrians per day respectively.
- Wednesdays experienced the lowest pedestrian volumes averaging 48,966 pedestrians per day.
- Pedestrian flow rates are the lowest in the morning around 6:30 AM.
- Pedestrian activity increases throughout the morning hours and into early afternoon until about 2:00 PM
- The pedestrian flow rates remain consistently high from 2:00 PM throughout the day until they begin to drop off after midnight.
- The highest pedestrian volumes were experienced during the month of September.
- December experienced the lowest monthly volumes.

Summary graphs from the year-long pedestrian counting program for hourly, daily and monthly observations are provided in Figure 1.5.

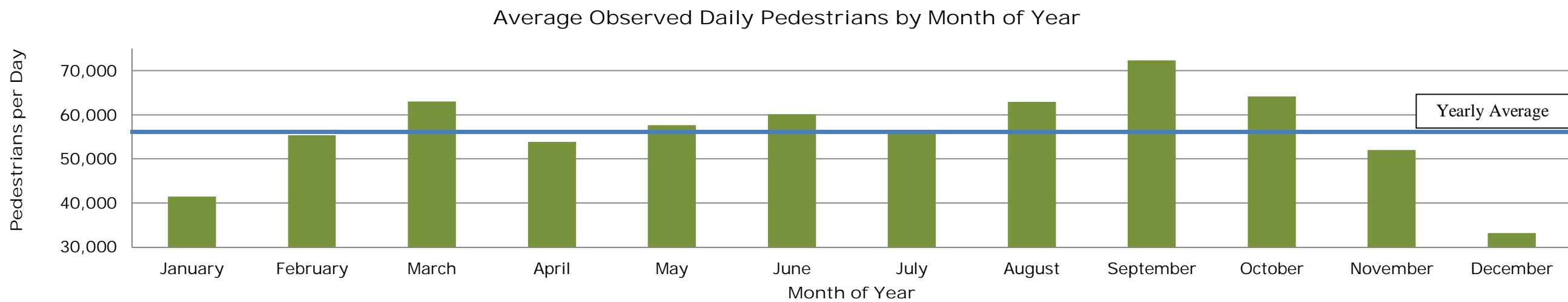
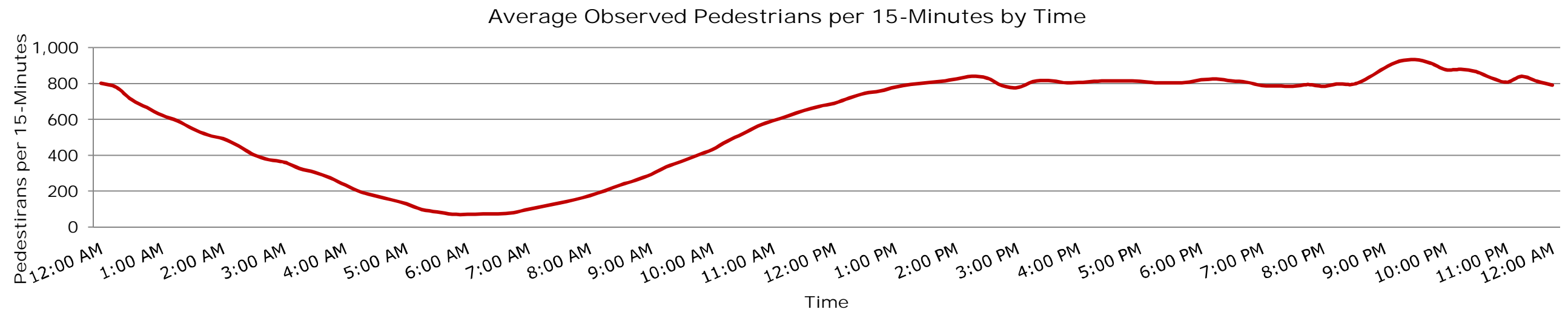
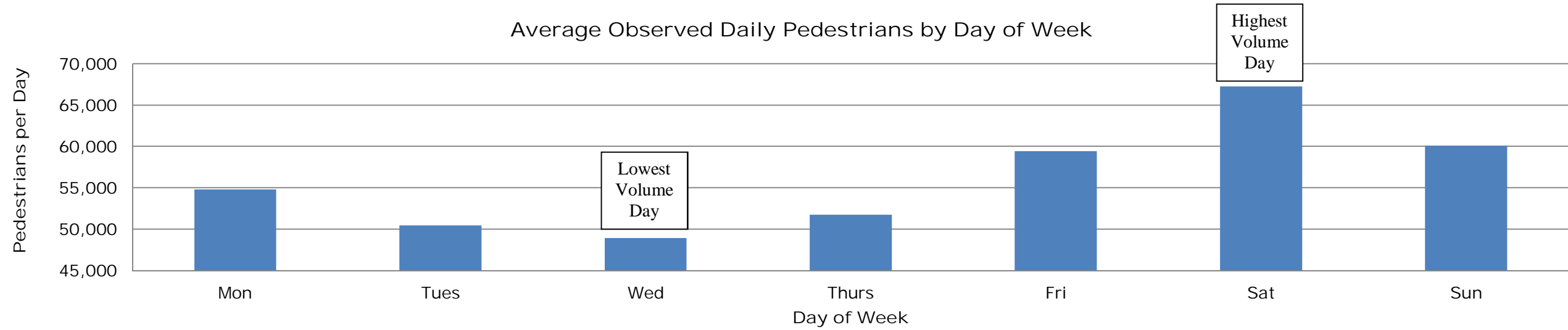

PEDESTRIAN VOLUME TRENDS OBSERVED AT IMPERIAL PALACE

FIGURE 1.5

2 STUDY APPROACH AND METHODOLOGY

The study approach was developed to achieve the goal of identifying locations of pedestrian walkway congestion by time of day and day of week along Las Vegas Boulevard from Russell Road to Sahara Avenue. To achieve this goal and to provide additional information on the Las Vegas Boulevard pedestrian environment, the following key study tasks were identified:

- Documentation of Existing Walkway Conditions
- Observation of Pedestrian Volumes
- Documentation of Pedestrian Walking Speeds
- Locations of Non-Permanent Obstructions
- Analysis and Evaluation of Collected Data
- Summarization of Conclusions and Recommendations

The study methodology for data collection was based on previous pedestrian observations that had determined Saturday to be the day of highest pedestrian activity on the "Strip". The data collection effort was also structured to identify variations in pedestrian activity by time of day and day of week including a Monday holiday weekend. The approach and method of pedestrian walkway volume and walking speed analysis was based upon the pedestrian level of service (LOS) procedures of the 2010 Highway Capacity Manual. Even though through the literature review there are recognized limitations to the manual's evaluation procedures, the use of the nationally recognized Highway Capacity Manual to evaluate and categorize pedestrian activity by its level of service metric is considered appropriate for this study. Upon reviewing the collected data and its associated LOS calculations, study recommendation and conclusions were developed.

2.1 Existing Conditions

Kimley-Horn and Associates conducted an inventory of existing conditions along the study corridor of Las Vegas Boulevard between Russell Road and Sahara Avenue. These efforts included the collection of existing pedestrian volume and walking speed data, historical vehicle volume data, walkway widths, location of news racks, bus stops, transit ridership, pedestrian containment, pedestrian/vehicle crash data and coordination with Clark County to document sidewalks in the public right-of-way and those within private easements.

The field inventory was performed in April and May 2012 by Kimley-Horn and Associates staff. The staff members walked the length of the study corridor a total of eight times to gather a comprehensive inventory of the pedestrian realm along Las Vegas Boulevard from Russell Road to Sahara Avenue. The field review included:

- Identification of permanent obstructions
- Non-functional driveways
- Existing no-obstructive use zones and accompanying white stripe
- Existing County ordinance 16.11 signs
- Existing sidewalk widths
- News rack locations
- Bus stop locations (and classification)
- Pedestrian containment (both on the walkway and in the median)
- General safety observations

The following sections detail the inventory of existing conditions along Las Vegas Boulevard from Russell Road to Sahara Avenue. The conducted research of public right-of-way and pedestrian easements, pedestrian/vehicle accident data, and vehicle volume data are also discussed.

2.1.1 Public Right-of-Way and Pedestrian Easements

Research conducted in close coordination with Clark County Public Works staff yielded a comprehensive exhibit that was prepared of the existing public walkways and the privately owned and maintained pedestrian walkways that are available to the public for pedestrian access. Exhibit A displays the existing public right-of-ways and pedestrian easements along Las Vegas Boulevard from Russell Road to Sahara Avenue. It should be noted that this exhibit is the summation of the best available information for this study. Picture 2.1 illustrates a location with both public and privately maintained walkways with a public pedestrian easement.



Picture 2.1 – Example of walkway with public ROW, pedestrian easement and private walkway.

2.1.2 Existing Walkway Widths (W)

To determine a pedestrian level of service along Las Vegas Boulevard, the total walkway width (W) and effective walkway width (W_E) need to be established. Through field measurements and survey records research, the walkway widths along study corridor were documented. Specifically, the walkway widths (W and W_E) were documented at each of the pedestrian volume data count locations and at various locations throughout the study corridor that were representative of the conditions along defined walkway segments. At these locations, the effective walkway widths (W_E) were calculated using the 2010 HCM methodology as described in Section 1.4.1. Shy distances were applied to permanent obstructions (i.e. fences, landscaping, trash enclosures, utility poles, bus shelters, fire hydrants, etc.) with the resulting width being the effective walkway widths (W_E).

Figure 2.1 shows the typical effective walkway widths (W_E) on the east and west sides of Las Vegas Boulevard. As a reference, the current design requirement for new construction within the Resort Corridor is to provide a minimum of ten feet of effective walk width (W_E) for all pedestrian facilities.

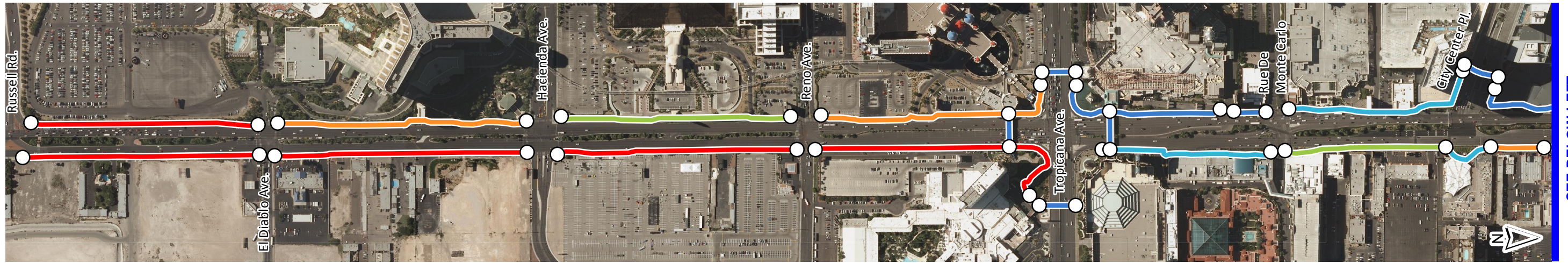

SEE BELOW LEFT

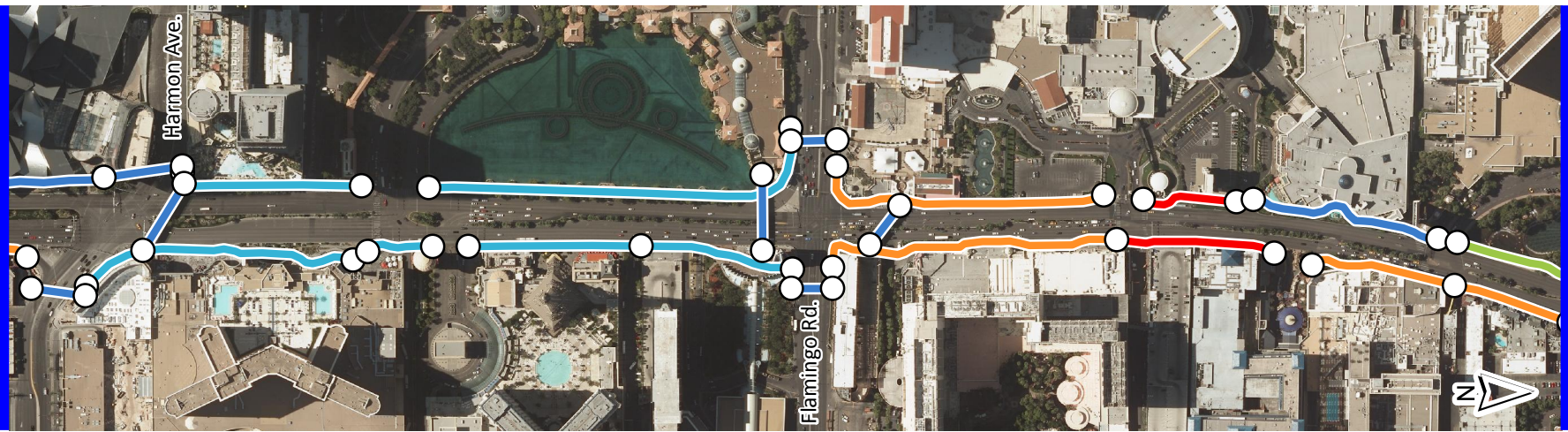

SEE ABOVE RIGHT

SEE RIGHT

SEE LEFT

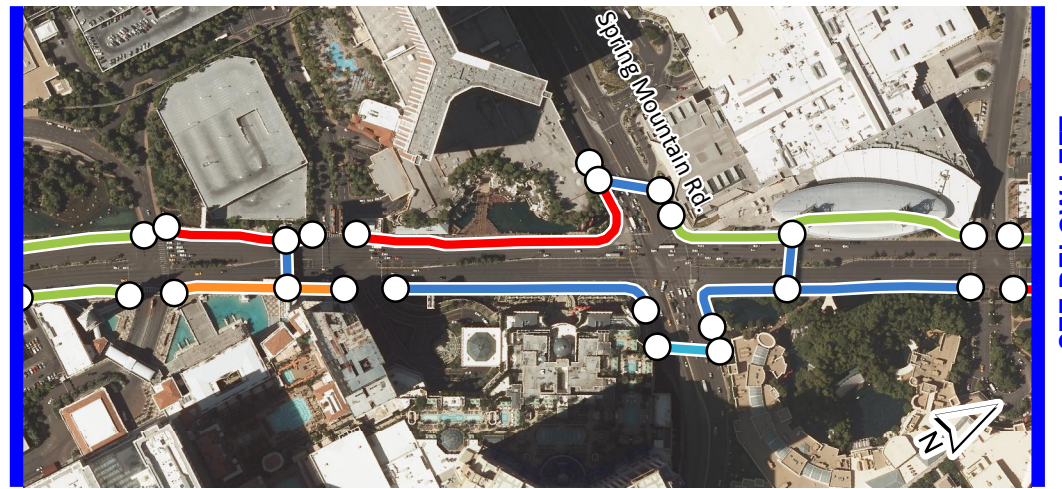



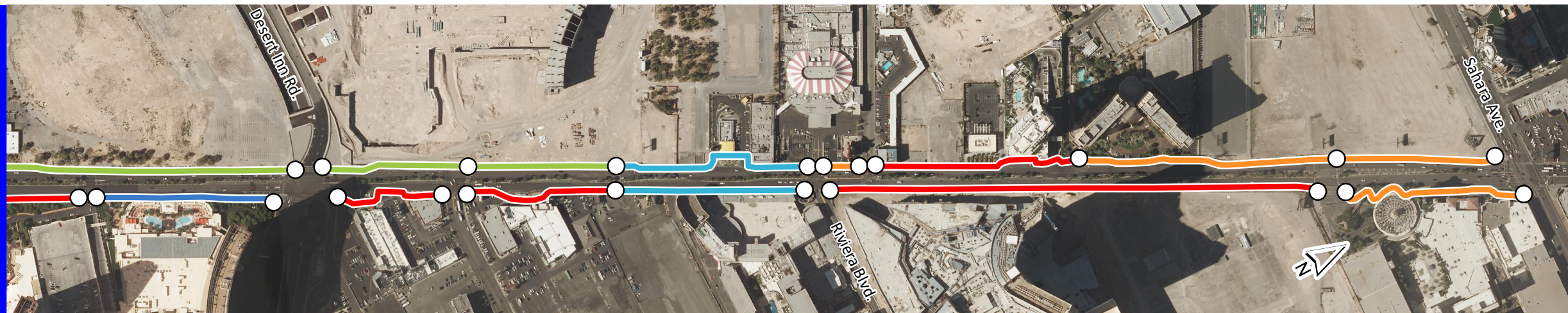



SEE BELOW LEFT



SEE ABOVE RIGHT

Legend

- Effective Walkway Width (W_e) (ft)
-  5.0 of less
 -  5.1 - 8.0
 -  8.1 - 10.0
 -  10.1 - 14.0
 -  Greater than 14.0
 -  Segment Limits

TYPICAL EFFECTIVE WALKWAY WIDTH (W_e) PER SEGMENT

FIGURE 2.1 9

2.1.3 Newsracks

The study corridor of Las Vegas Boulevard has many permitted obstructive uses per Clark County Code 16.11 on its walkways. One example of a permitted obstruction is the newsrack. Newsracks allow pedestrians to obtain various forms of literature, either free or for a nominal fee. Newsracks are only permitted in locations licensed by Clark County. These permitted locations are referred to as “medallion” locations. The location of each newsrack in the study corridor was field verified on April 18, 2012. A total of 237 individual newsracks at 40 locations were observed during the field visit, with 138 newsracks at 23 locations on the east side and 99 newsracks at 17 locations on the west. At all locations except one, the individual newsracks are clustered together in a group of six. At the time of the field study, one location (southernmost location on the west side of Las Vegas Boulevard within the study corridor) was found to have a cluster of only three newsracks. The locations of medallion and non-medallion newsracks are shown in Figure 2.2.

Newsracks are installed in various locations in relation to the walkway. Newsracks were typically placed at the front of the walkway (between the street and the walkway), at the back of the walkway or against a pedestrian containment barrier. Picture 2.2 through Picture 2.4 illustrate examples of these typical installations.



Picture 2.3 – Newsracks at Back of Walkway.



Picture 2.2 – Newsracks at Front of Walkway.



Picture 2.4 – Newsracks against Pedestrian Containment.

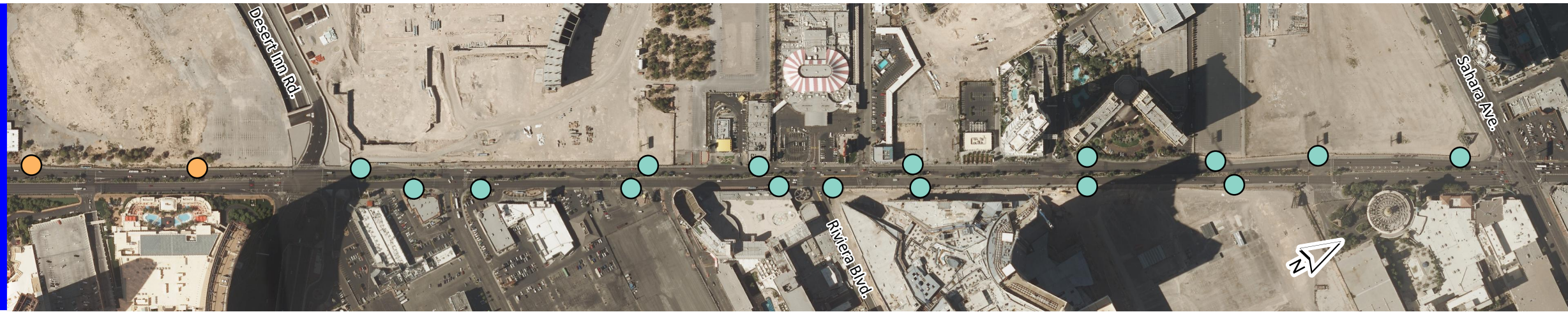

SEE ABOVE RIGHT

NEWSRACK LOCATIONS

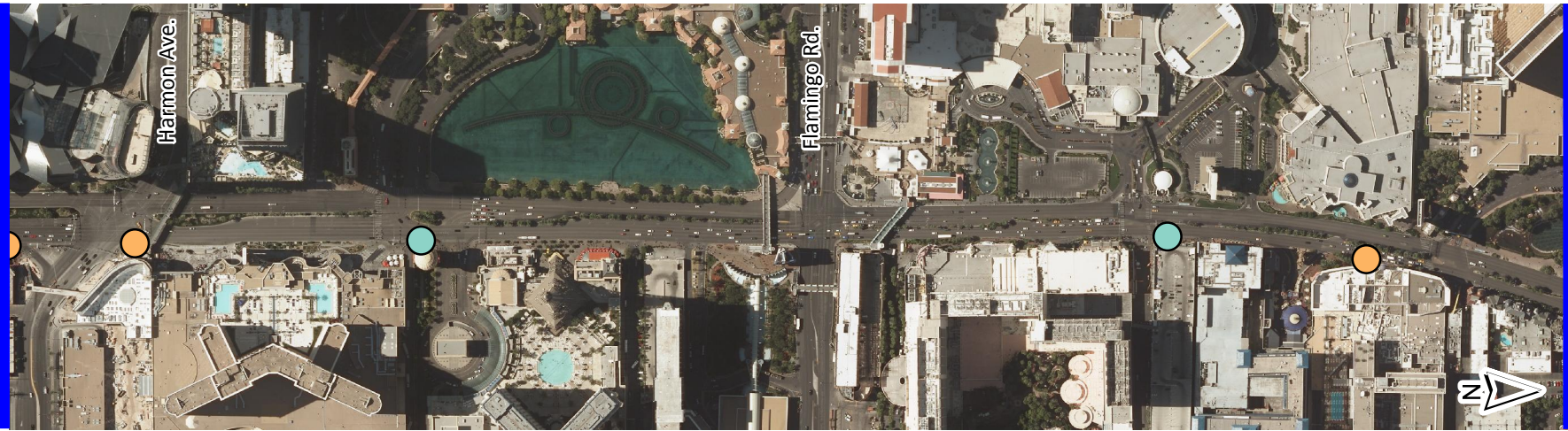

SEE ABOVE RIGHT

SEE RIGHT

SEE LEFT



SEE BELOW LEFT

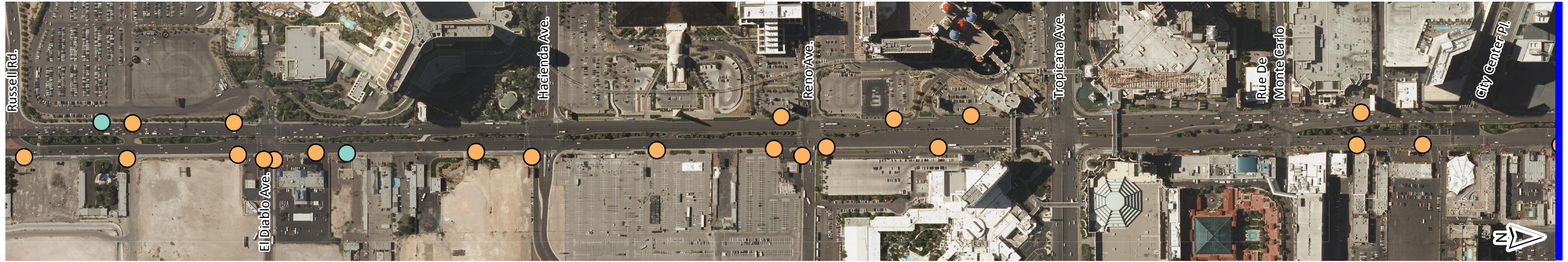

SEE BELOW LEFT

Legend

News Racks

- Medallion Locations
- Non-Medallion Locations

FIGURE 2.2 11

2.1.4 Bus Stops

The study corridor of Las Vegas Boulevard is serviced by two bus routes, the DEUCE and the SDX. Picture 2.15 shows both the typical double decker DEUCE bus and the SDX bus at the Wynn bus stop.



Picture 2.5 – SDX and DEUCE Buses at Wynn Bus Stop.

Twenty-Nine (29) bus stops are located along Las Vegas Boulevard between Russell Road and Sahara Avenue, two of which do not have a shelter structure. These 29 bus stops were all field-verified and classified into the following three types:

- **Type 1 – (Isolated)** – These bus stops are separate from the main pedestrian walkway; typically, a separate walkway is provided from the main walkway to access the bus stop and shelter. Figure 2.3 illustrates both graphically and pictorially a Type 1 bus stop. A total of five (5) Type 1 bus stops were found within the study corridor, with their locations shown on Figure 2.6.
- **Type 2 – (Front of Walk)** – Bus stops were classified as Type 2 if the pedestrian walkway was located behind the bus shelter. Figure 2.4 illustrates both graphically and pictorially a Type 2 bus stop. A total of ten (10) Type 2 bus stops were found within the study corridor, with their locations shown on Figure 2.6.

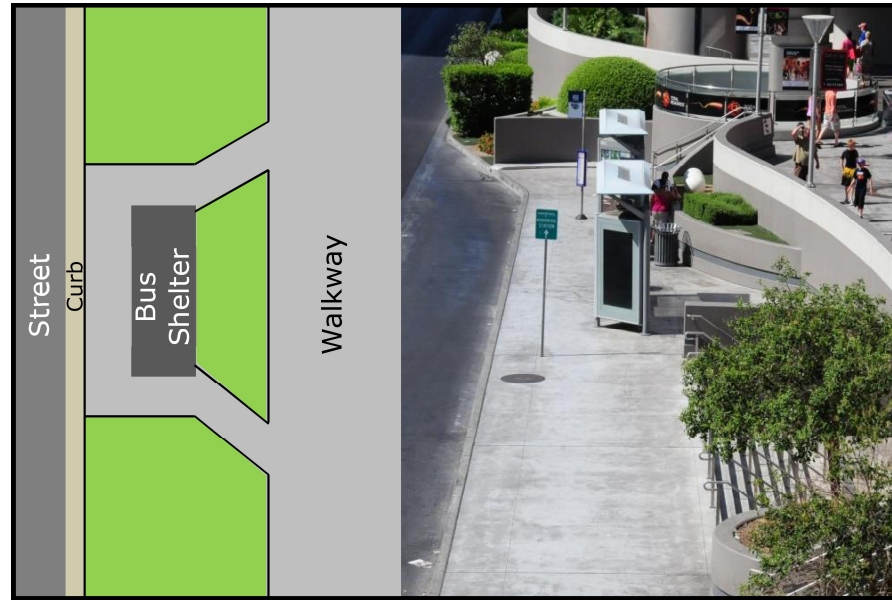

Figure 2.3 – Type 1 (Isolated) Bus Stop Example



Figure 2.4 – Type 2 (Front of Walk) Bus Stop Example

- **Type 3 – (Behind Walk)** – This classification was applied to bus shelters and 2 bus benches that are located behind the pedestrian walkway. Type 3 bus stops route pedestrian traffic between the bus shelter or bus benches and the street. Figure 2.5 illustrates both graphically and pictorially a Type 3 bus stop. A total of fourteen (14) Type 3 bus stops were found within the study corridor, with their locations shown on Figure 2.6.



Figure 2.5 – Type 3 (Behind Walk) Bus Stop Example

Table 2.1 summarizes the 29 bus stops by type, location and transit direction of travel.

Table 2.1 – Bus Stop Summary

	Type 1 (Isolated)	Type 2 (In Front of Walk)	Type 3 (Behind Walk)
BUS STOP NAME	Sky Condominiums (S)	Riviera (N)	Sahara (S)
	Convention Center (N)	Circus Circus (S)	Hilton Grand Vac. (N)
	Fashion Show (S)	Venetian (N)	Hilton Grand Vac. (S)
	Planet Hollywood (N)	Mirage (S)	Turnberry Place (N)
	MGM-Showcase (N)	Caesars Palace (S)	Convention Center (S)
		Flamingo (N)	Encore (S)
		Paris (N)	Wynn (N)
		Monte Carlo (S)	Treasure Island (S)
		Excalibur (S)	Bellagio (S)
		Four Seasons (N)	Polo Towers (N)
			Tropicana (N)
			Luxor (S)
			Luxor (N)
			Mandalay Bay (S)

(N) – Northbound Transit Stop, Eastside of Las Vegas Boulevard
(S) – Southbound Transit Stop, Westside of Las Vegas Boulevard

To supplement the field inventory data, ridership at each stop within the study corridor was obtained from the Regional Transportation Commission of Southern Nevada (RTC). Boarding and alighting data was provided by the RTC for Saturday, May 26 and Saturday, June 16, 2012.



SEE ABOVE RIGHT

BUS STOP TYPE AND LOCATION

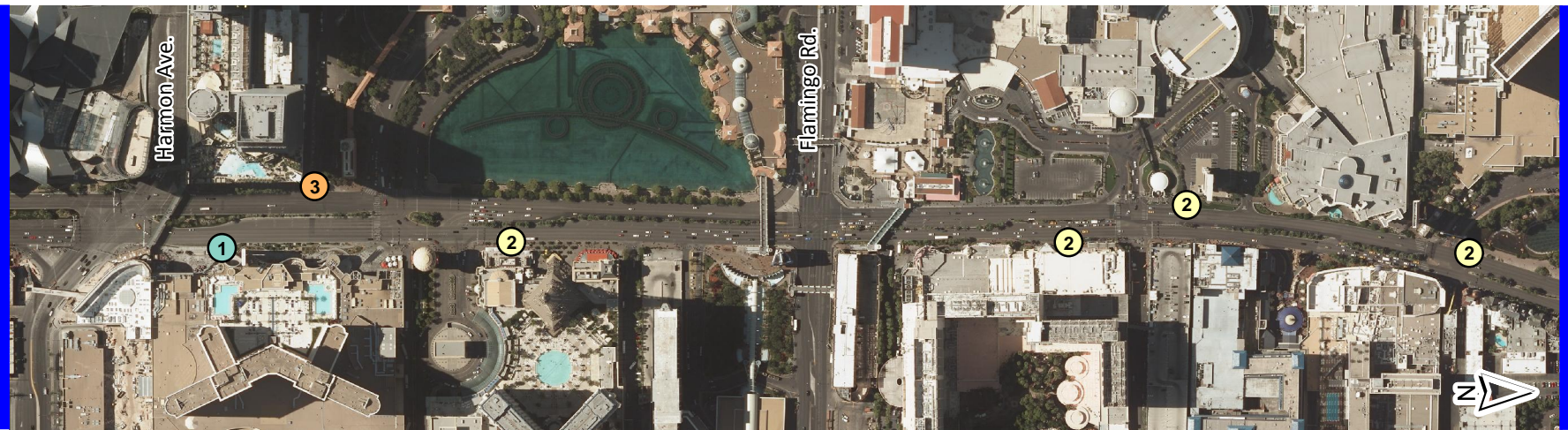

SEE ABOVE RIGHT

SEE RIGHT

SEE LEFT



SEE BELOW LEFT



SEE BELOW LEFT

Legend

Bus Stop

- ① Type 1 (Isolated)
- ② Type 2 (In Front of Walk)
- ③ Type 3 (Behind Walk)

FIGURE 2.6 13

2.1.5 Pedestrian/Vehicle Crash Data

With large numbers of pedestrian and vehicle traffic along Las Vegas Boulevard, pedestrian safety is an important issue. Figure 2.7 displays the 2010 Average Annual Daily Traffic (AADT) for Las Vegas Boulevard and the connecting street network. With vehicle demands of over 50,000 vehicles each day, pedestrian safety is inherently a concern.

A summary of the most recent crash data from the Nevada Department of Transportation (NDOT) showed that from October 2008 to September 2011, 2,433 crashes between vehicles and pedestrians occurred within Clark County. Of those 2,433 crashes, 63 or 2.6% occurred on Las Vegas Boulevard in the four-mile segment between Russell Road and Sahara Avenue. There were a total of 124 pedestrian/vehicular crashes in Clark County that resulted in fatalities for the three year period. Of those 124 crashes, 1 or 0.8% occurred within the study corridor. Picture 2.6 shows emergency vehicles on Las Vegas Boulevard.



Picture 2.6 – Emergency Vehicles on Las Vegas Boulevard.



Picture 2.7 – Vehicle Activity on Holiday Saturday of Memorial Day Weekend 2012.

Figure 2.8 shows the locations and severity of the pedestrian/vehicle crashes within the study corridor.

Upon reviewing Figure 2.8, one can see that the pedestrian/vehicle crashes occur throughout the full length of the “Strip” from Russell Road to Sahara Avenue. It can also be seen that 11 crashes occurred within intersections served by pedestrian bridges constructed with pedestrian containment measures. Picture 2.7 shows the typical evening traffic on the “Strip”.

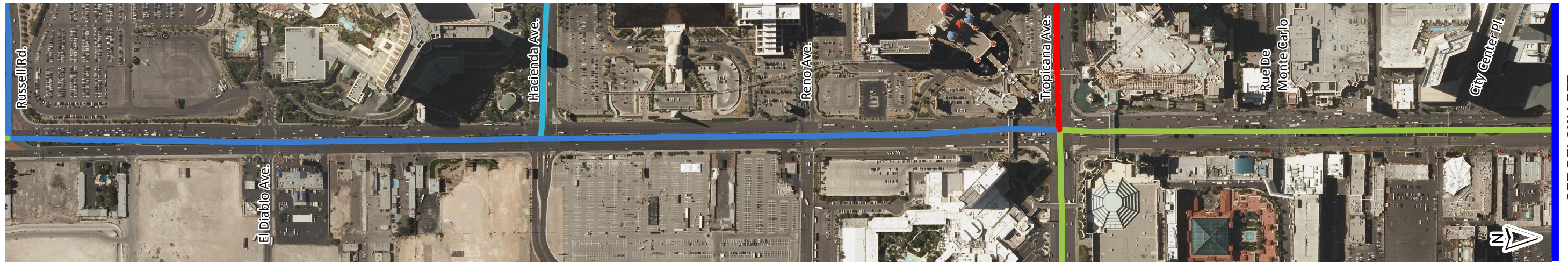

SEE BELOW LEFT

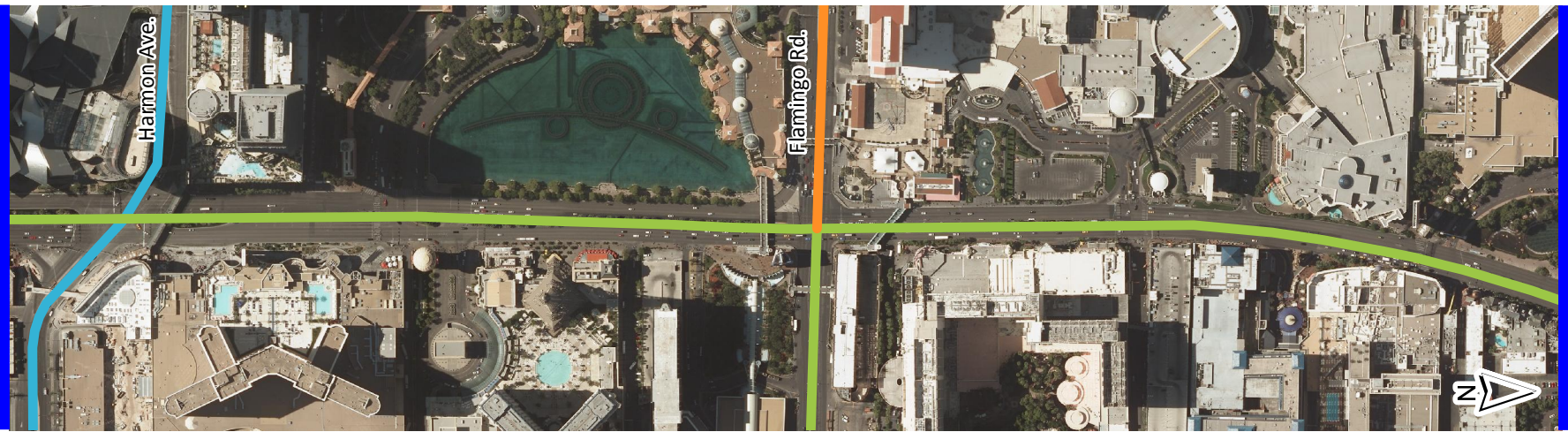

SEE ABOVE RIGHT

SEE RIGHT

SEE LEFT





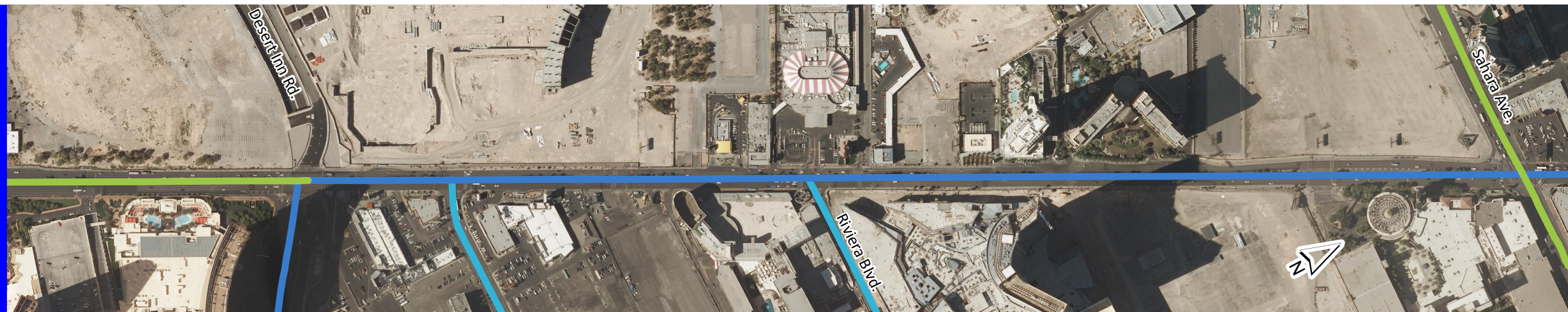

SEE BELOW LEFT



SEE ABOVE RIGHT

Legend

- 2010 AADT**
-  25,000 or Less
 -  25,001 - 50,000
 -  50,001 - 75,000
 -  75,001 - 100,000
 -  Greater than 100,000

2010 AVERAGE ANNUAL DAILY TRAFFIC (AADT) - VEHICLES

FIGURE 2.7 15

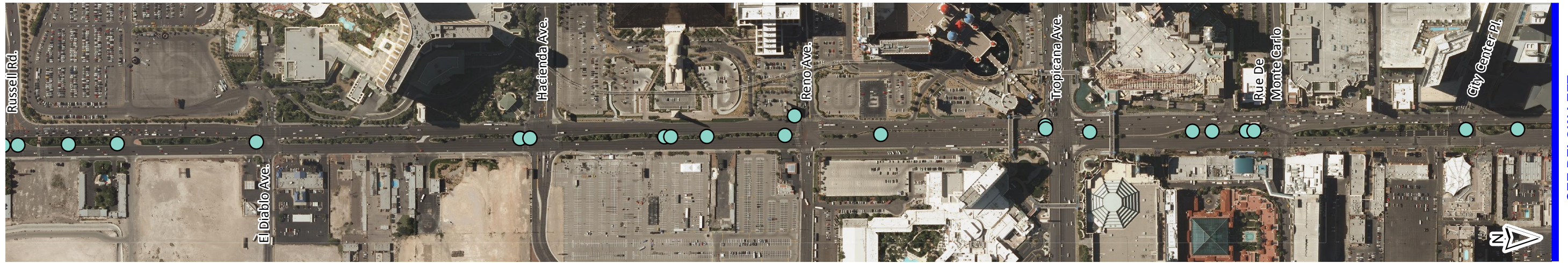

SEE BELOW LEFT

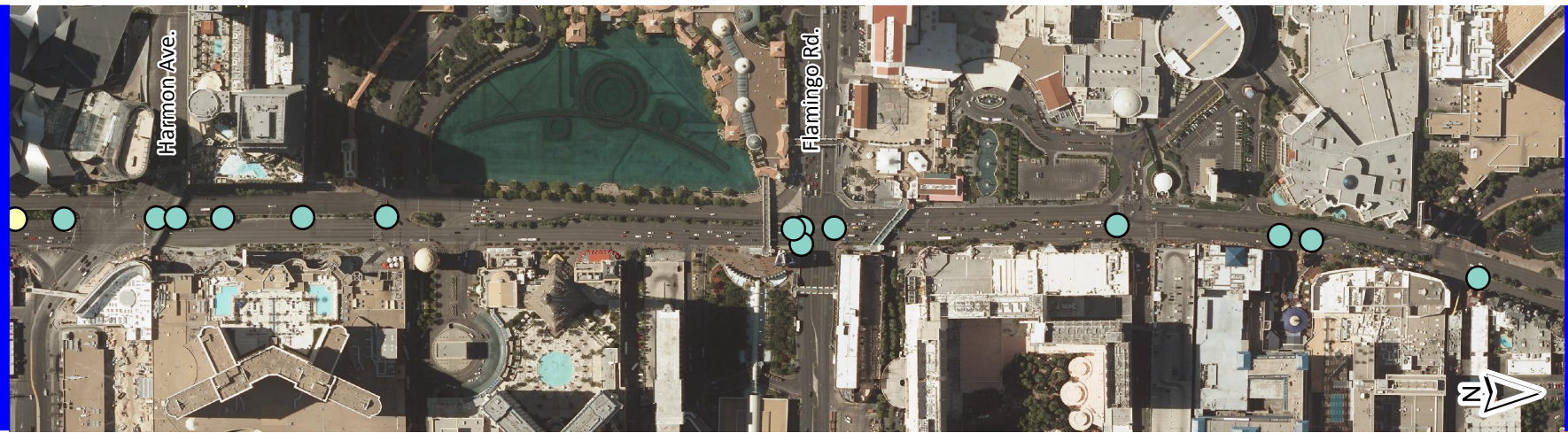

SEE ABOVE RIGHT

SEE RIGHT

SEE LEFT



SEE BELOW LEFT

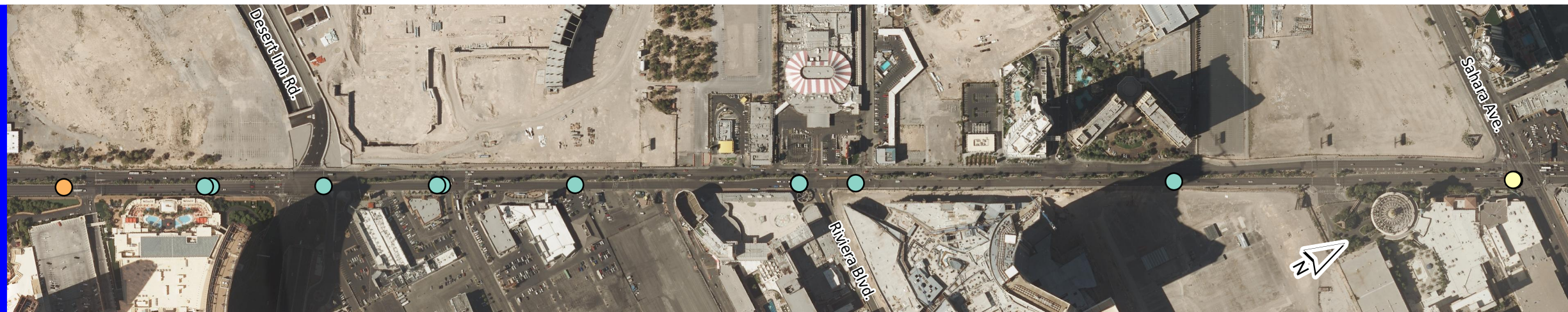

SEE ABOVE RIGHT

Legend

Pedestrian/Vehicle Crash Severity

- Pedestrian Fatality
- Pedestrian Injury
- Property Damage Only

Source: NDOT Safety Engineering
Locations are approximate based on NDOT georeferencing

PEDESTRIAN CRASH LOCATION AND SEVERITY - OCTOBER 2008 TO SEPTEMBER 2011

FIGURE 2.8 16

2.1.6 Pedestrian Containment

Pedestrian containment is a physical barrier or a system of barriers that act to restrict and direct pedestrian movements. They can also be used to separate pedestrians from adjacent hazards such as an adjacent roadway and its vehicle traffic. Pedestrian containment continues to evolve along Las Vegas Boulevard as new walkway and roadway projects are constructed. Pedestrian containment measures along Las Vegas Boulevard (the "Strip") have been developed over the years in many forms. Within the study corridor, pedestrian containment is located within the roadway median and on the curbside adjacent to the travel lanes of Las Vegas Boulevard. Pictures Picture 2.8 through Picture 2.12 show the types of containment barriers that have been constructed that include:

- Decorative concrete or brick walls
- Decorative metal fencing
- Concrete median barriers
- Rope and Cable barriers
- Elevated walkways
- Landscape treatments

The location and length of existing pedestrian containment was field verified as part of this study and is illustrated in Figure 2.9. A total of 13,360 linear feet of curbside containment was identified, along with 3,100 linear feet of median containment.



Picture 2.9 – Metal Fence Median Barrier.



Picture 2.11 – Back of Curb Cable Barrier.



Picture 2.8 – Back of Curb Concrete Wall and Landscape Treatment.

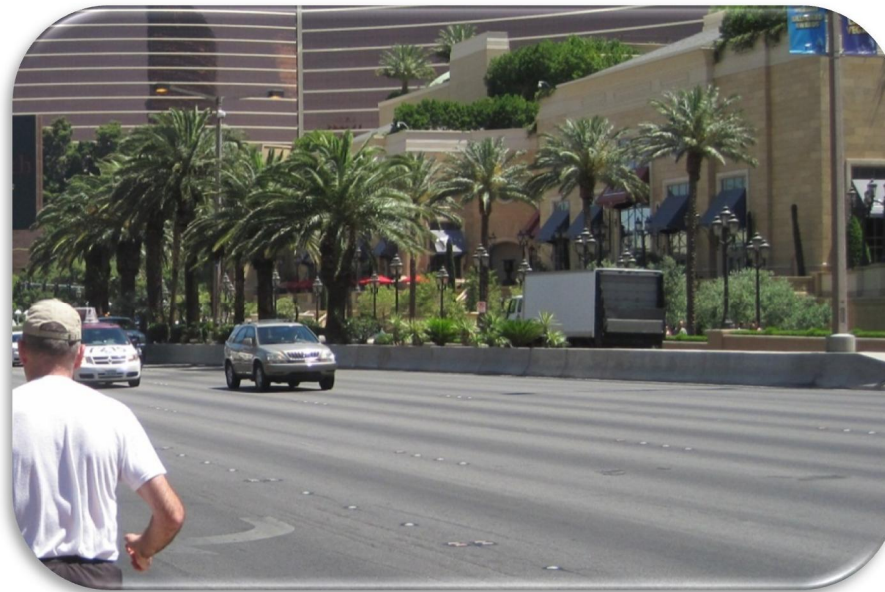

Picture 2.10 – Concrete Median Barrier.



Picture 2.12 – Back of Curb Elevated Landscaping Barrier.



SEE BELOW LEFT



SEE ABOVE RIGHT

SEE RIGHT
SEE LEFT



SEE BELOW LEFT



SEE ABOVE RIGHT

Legend

Pedestrian Containment

 Curb - 13,360 LF

 Median - 3,100 LF

PEDESTRIAN CONTAINMENT LOCATIONS

FIGURE 2.9

2.1.7 Construction Activities

Another key element documented during the course of the study, was the location of construction and maintenance activities within the study corridor that could influence walking speeds and pedestrian volumes during the observation periods. Some of the noted activities included:

- Renovations at the MGM Grand Hotel/Casino
- The Caesars Linq project along the frontage of the former O'Shea's Casino and Imperial Palace Hotel/Casino
- Sidewalk reconstruction at the Venetian Hotel/Casino
- Building / signage modifications at Harmon Center

Picture 2.13 through Picture 2.21 illustrate some of the construction and maintenance activities encountered during the data collection phase of the study.



Picture 2.13 – South Entrance to Pedestrian Walkway through Linq Construction.



Picture 2.14 – Pedestrian Walkway through Linq Construction.



Picture 2.15 – Pedestrian Bridge Detour at Harmon Center from Cosmopolitan Hotel/Casino.



Picture 2.16 – Caesars Linq Construction.

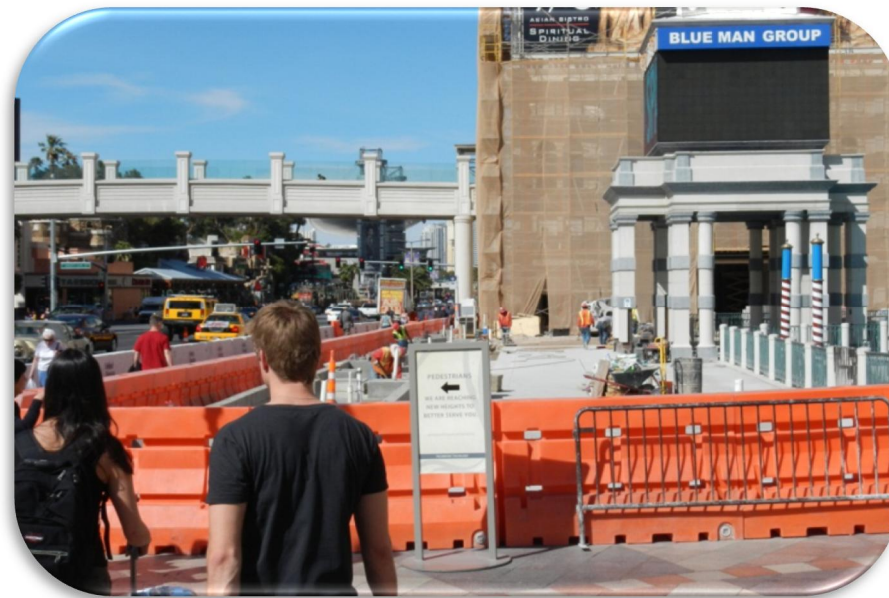

Picture 2.18 – Venetian Hotel/Casino Walkway Construction.

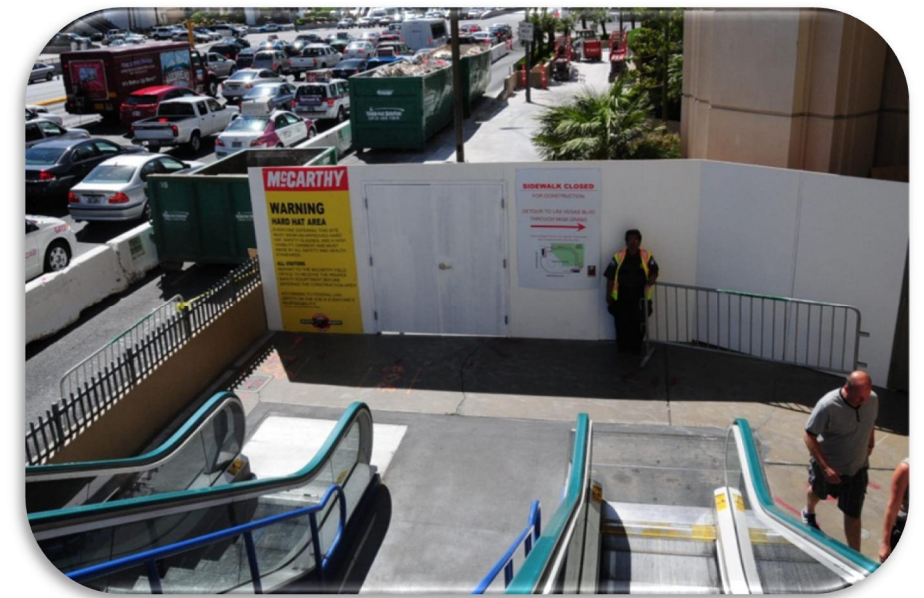

Picture 2.20 – MGM Grand Hotel/Casino Renovation Detour.



Picture 2.17 – Bus Turnout Construction at Harrah's Hotel/Casino.



Picture 2.19 – Building/Signage Modifications at Harmon Center.



Picture 2.21 – Landscaping/Utility Construction at the Flamingo Hotel/Casino.

2.2 Data Collection

To capture the variations in pedestrian activity and the pedestrian environment along Las Vegas Boulevard from Russell Road to Sahara Avenue, a data collection program was established for the study. The data collection program primarily focused on the collection of pedestrian volume data and walking speeds for the purpose of documenting the location of pedestrian congestion by time of day and day of week within the study corridor. The data collection effort was also intended to build upon and update the findings of the 1994 Lee Engineering *Las Vegas Boulevard South Pedestrian Study*. During the data collection phase of the study, non-permanent obstructions were observed. It is important to note that the term “non-permanent obstruction”, for the purposes of the data collection phase of the study and for this report, is defined as an individual who could obstruct the pedestrian walkway while engaging in any of the following activities within the walkway: hand billing, performing, soliciting or selling.

Several factors influenced the development of the data collection program:

- Determination of observation times (Day of week – Time of day)
- Location of pedestrian observation sites
- Method of pedestrian counting
- Method of walking speed determination
- Observation of non-permanent obstructions

From the conducted literature review, Saturday was first identified in the 1993 Clark County Public Works study as the day of peak pedestrian volume. The peak time periods of the day were reported to occur around 2:00 PM and in the late evening around 10:00 PM. These findings were reconfirmed by the year-long 2010 Caesars International Pedestrian Study (see Figure 1.5). The Caesars study also confirmed the peak pedestrian times could be expected to occur between 2:00 PM and midnight. In consultation with the County, the primary pedestrian volume data collection times for this study were identified for a Saturday of a holiday weekend and on a typical Saturday. Based upon the study schedule, May 26, 2012, the Saturday of Memorial Day Weekend, and June 16, 2012 were selected.

Memorial Day Weekend provided congested pedestrian conditions for Las Vegas Boulevard (the “Strip”). According to Priceline.com and Orbitz.com, the number one travel destination for Memorial Day Weekend 2012 was Las Vegas. Information compiled by the Las Vegas Convention and Visitors Authority determined the Resort Corridor hotel occupancy for the 2012 Memorial Day weekend as 96.0% (this total includes some hotels not located on Las Vegas Boulevard and within the study corridor). A number of large events were scheduled at numerous venues along the study corridor including concerts, comedians, and an Ultimate Fighting Championship (UFC) event. Picture 2.22 illustrates the activity level observed on Saturday, May 26, 2012.

The Las Vegas Convention and Visitors Authority verified June 16 as a typical summer Saturday with no significant events occurring and reported the Resort Corridor hotel occupancy for the 2012 weekend of June 16 as 94.7% (this total also includes some hotels not located on Las Vegas Boulevard and within the study corridor).

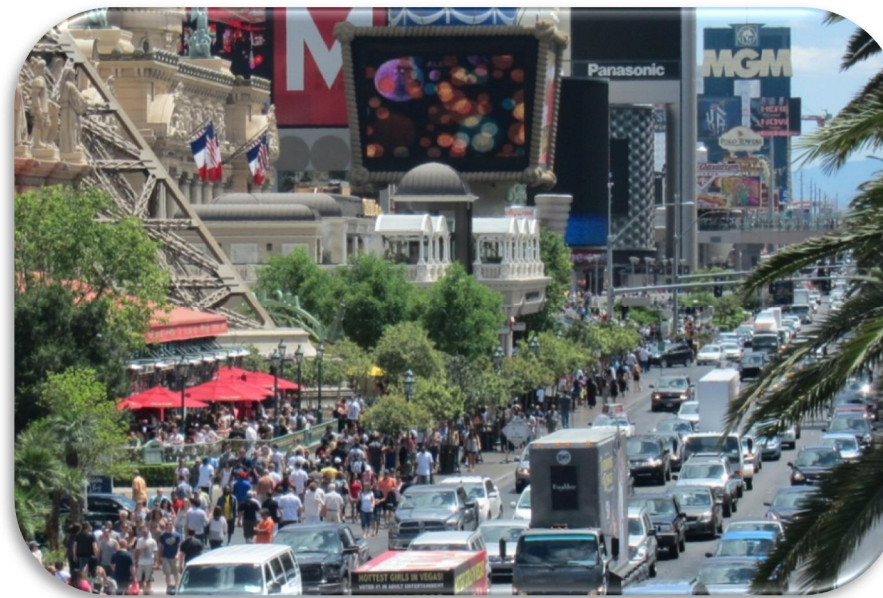

Picture 2.22 – Activity Level on Memorial Day Weekend.

To verify the daily and weekday pedestrian characteristics reported in the 2010 Caesars International Study for the sidewalk in front of Imperial Palace Hotel/Casino were applicable for other sections of the study corridor; additional seven-day pedestrian counts were included in the data collection program. Six video cameras were used to observe pedestrian activities for 14 days each. Four video cameras were installed by Clark County for the study and two Metropolitan Police Department observation cameras were used for the data collection. The seven-day observations were programmed to occur between May 25 – May 30 and June 15 – June 21 (including the two primary study days). The six observation sites selected to represent the study corridor include:

- Westside sidewalk at New York-New York Hotel/Casino
- Eastside sidewalk at Harley Davidson Cafe
- Westside sidewalk at Bellagio Hotel/Casino
- Pedestrian Bridge between Caesars Palace Hotel/Casino and Bill’s Gamblin’ Hall & Saloon
- Eastside sidewalk at Venetian Hotel/Casino
- Westside sidewalk at Treasure Island Hotel/Casino

The pedestrian observation sites for the data collection program were selected based upon the goal of documenting variations in pedestrian volumes along Las Vegas Boulevard between Russell Road and Sahara Avenue. The preferred method of pedestrian observation for the study was to use video recordings. Coordination with the gaming industry proved extremely helpful in identifying locations where existing surveillance cameras could be made available for the data collection program. Where video observation coverage was not available, manual count locations were identified. The pedestrian count locations identified for the study are summarized in Figure 2.10. The locations are on the east and west sides of Las Vegas Boulevard as well as the pedestrian bridges for the entire 4.2 miles of the study corridor. The observed pedestrians during the video

and manual counts were classified as assisted or unassisted. The assisted pedestrians were defined as pedestrians who use canes, wheelchairs or scooters. By classifying the pedestrian flow, the collected data can determine the percentage of individuals who may be traveling at a slower walking speed.

The pedestrian volume data used in this study is the result of a total of 192 hours of manual counts and 2,568 hours of recorded video at 38 unique locations within the study corridor. These 38 locations included 12 pedestrian bridges (9 video and 3 manual) and 24 walkway locations (14 video and 10 manual). This report and its conclusions are based upon approximately 4,835,000 observed pedestrians within the study corridor as counted between May 25 and June 22, 2012.

A walking speed study was developed to document variations in pedestrian walking speeds as a part of the data collection program. During the peak pedestrian periods (1:00 PM to 12:00 AM) of the primary pedestrian volume observation days, pedestrian walking speeds were observed. To be able to compare peak period walking speeds with non-congested conditions, a free-flow walking study was also conducted. The free-flow walking speed study was programmed to occur at the time of low (non-congested) pedestrian volumes within the study corridor. Using the year-long 2010 Caesars International Pedestrian Study (see Figure 1.5), 9:00 AM Wednesday morning was selected to observe free-flow walking speeds. For the study, Wednesday, April 25 was selected to conduct the free-flow study.

The collected pedestrian walking speed data for this study is the result of 160 man-hours of data collection by agents (walking individuals) walking a total of 355 miles. These efforts include completing 80 walking trips between Russell Road and Sahara Avenue. During these trips, a total of 4,329 time points were recorded. These time points represented 56 unique locations on the eastside and 55 locations on the west side of Las Vegas Boulevard. The time points and the distance between them determined the walking speeds for various segments of walkway (including all nine north/south pedestrian bridges) within the study corridor for the free-flow and peak period walking studies.

The following sections provide additional detail on the data collection program and its implementation during the study.

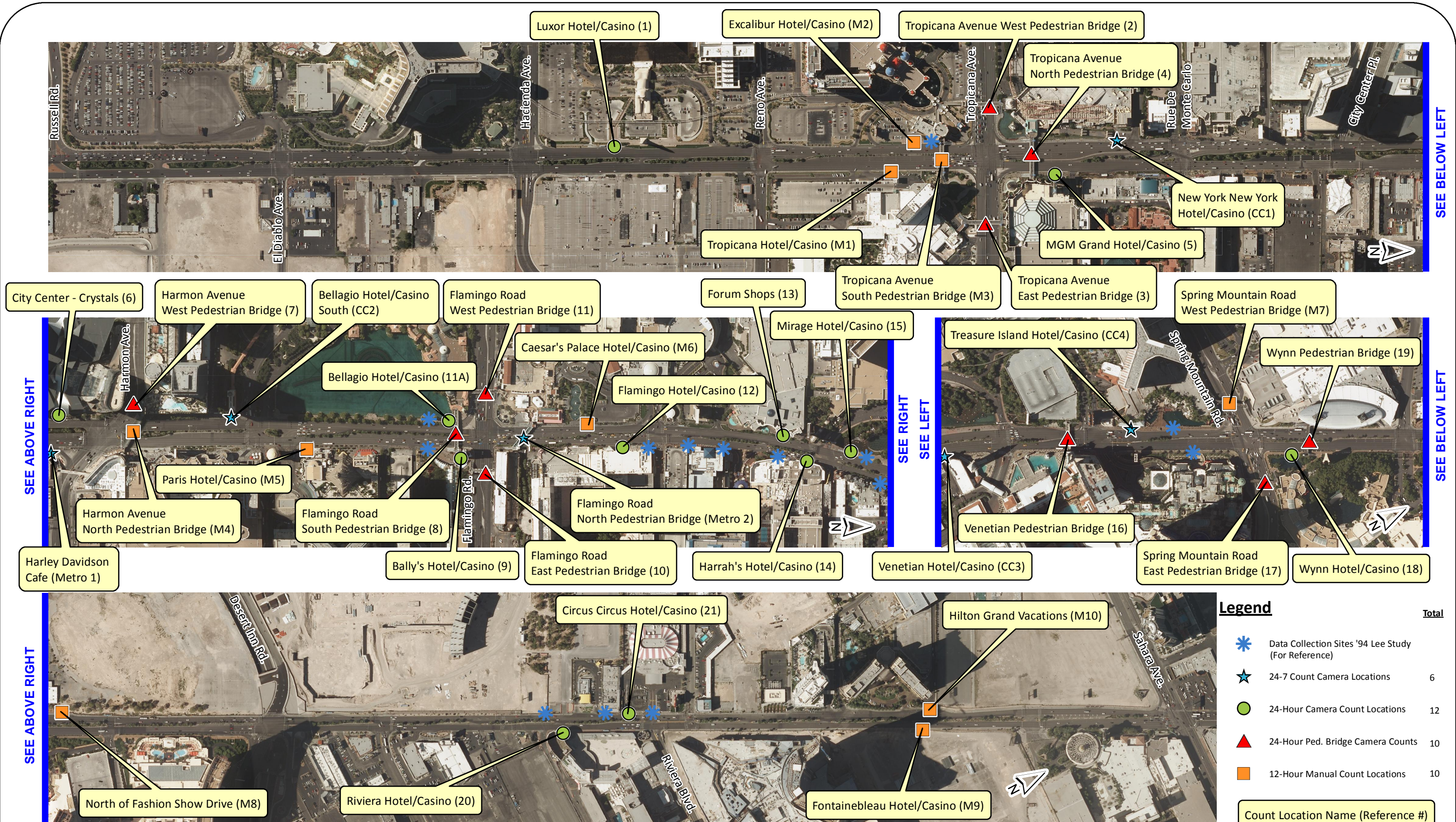

PEDESTRIAN VOLUME COUNT LOCATIONS

FIGURE 2.10 22

2.2.1 Pedestrian Counts - Video

According to the “Manual of Transportation Engineering Studies” (1994) by the Institute of Transportation Engineers (ITE), the use of video data collection allows for greater accuracy than other volume data counting methods. Video recordings create a permanent record that can be viewed repeatedly in slow motion for counting accuracy. Video data collection can also be less labor intensive requiring fewer observers in the field. Through close coordination with the gaming industry, property owners, Metropolitan Police Department, and Clark County Public Works, 29 surveillance cameras were made available for the study. The following properties contributed video recordings:

- MGM Resorts International (including the MGM Grand, Mandalay Bay, Luxor, Excalibur, New York-New York, City Center, the Bellagio, Mirage and Circus Circus),
- Caesars Entertainment (including Bally’s, the Flamingo and Harrah’s),
- InterContinental Alliance Resorts (including the Venetian and the Palazzo),
- Riviera Hotel/Casino, and
- The Forum Shops.

In addition, the Metropolitan Police Department (Metro) provided two surveillance cameras for the study. The Metro cameras were used to observe 14-days of pedestrian activity on the pedestrian bridge between Ceasars Palace Hotel/Casino and Bill’s Gambler’s Hall & Saloon at Flamingo Road and at a known geometrically constrained walkway location near the Harley Davidson Cafe at Harmon Avenue (see camera locations on Figure 2.10). Camera observation views for each location were selected by Kimley-Horn staff to assure that all video footage would provide suitable data for collecting pedestrian volume counts. It should be noted that as data was analyzed there were segments of time that were not available for pedestrian counting. Occasionally, the participating property owners required their cameras for surveillance functions. Once the security issue was resolved, the camera was returned to the study observation position and the data collection resumed. Clark County deployed four additional cameras for video data collection. Kimley-Horn coordinated with the County to install the cameras in strategic locations for video coverage at locations that were not covered by other cameras or manual counting. Each camera was manually adjusted to the desired location before each week-long study period. The cameras were removed following each data collection session and the video data was subsequently downloaded from the cameras. A typical camera installation is shown for the Treasure Island Hotel/Casino north of Siren’s Cove Boulevard and south of Spring Mountain Road in Picture 2.23.



Picture 2.23 – Clark County Camera at Treasure Island Hotel/Casino.

Once the video data was collected by Kimley-Horn in cooperation with the individual property owners and their surveillance/security departments, the videos were viewed and pedestrian volumes were documented in 15-minute increments by trained counting staff. Assisted walkers (pedestrians using canes, walkers, wheelchairs or scooters) were also identified in the videos and separately counted as part of the existing pedestrian conditions.

The video data collection effort for the study is summarized below by date and total hours observed for the study.

▪ Private Camera Locations			
18 locations	5/26/2012	=	400 hours
20 locations	6/16/2012	=	427 hours
▪ Metro Camera Locations			
2 locations	5 /25-6/1/2012	=	336 hours
2 locations	6/15-6/22/2012	=	336 hours
▪ County Camera Locations			
4 locations	5/26-6/1/2012	=	491 hours
4 locations	5/26-6/1/2012	=	<u>578 hours</u>
			2,568 hours

2.2.2 Pedestrian Counts - Manual

Manual pedestrian counts were collected at various locations on Las Vegas Boulevard from Russell Road to Sahara Avenue to supplement the video data. The manual counts were conducted from 12:00 PM to 12:00 AM (noon to midnight) on both Saturday, May 26 and Saturday, June 16, 2012. Picture 2.24 shows a manual counter documenting pedestrian traffic on the pedestrian bridge between the Harmon Center and the Cosmopolitan Hotel/Casino.



Picture 2.24 – Manual Counter on Pedestrian Bridge.

The manual counts were conducted by trained counting staff. JAMAR count boards (see Picture 2.25) were used to accurately record the volume of pedestrians passing a single point on the walkway at each count location. Manual counters were strategically placed on walkways and pedestrian bridges where video observation was not available. As a part of the manual counting, assisted walkers (pedestrians using canes, walkers, wheelchairs or scooters) were also identified and documented.

The 12-hour count period allowed the capture of pedestrian volume peaks in both the early afternoon and evening when pedestrian volumes have historically been the highest. In addition, during the May 26 count period when a high pedestrian volume location was identified, the counting staff was increased to assure an accurate count was obtained.

Figure 2.10 shows the location of each of the manual count locations numbered from south to north starting with M1. The Clark County cameras are labeled beginning with "CC1" and the Metro cameras are labeled "Metro1" and "Metro2". 38 locations were used for data collection throughout the study corridor.

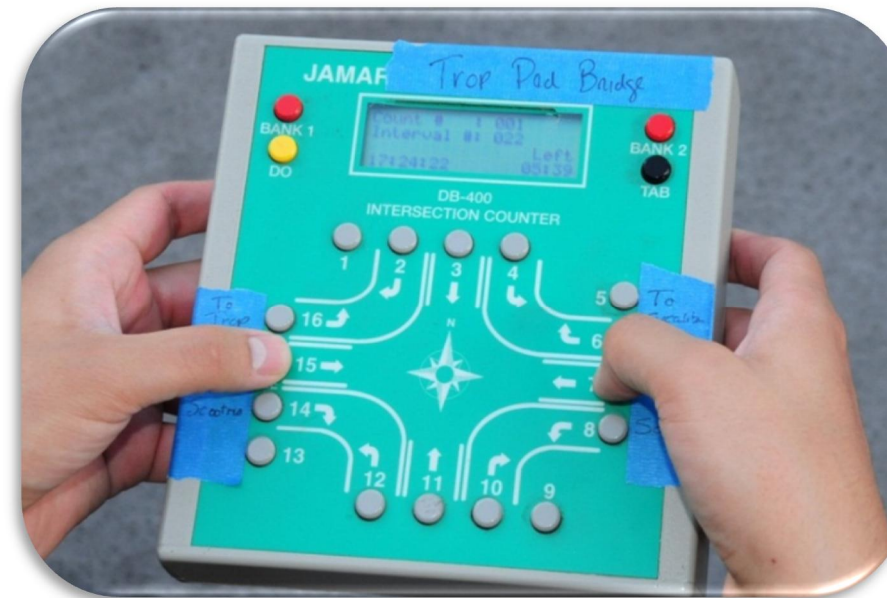

Picture 2.25 – JAMAR Count Board for Manual Pedestrian Volume Counts.

Following the Saturday, May 26 Memorial Day weekend count, the manual count data was reviewed. The purpose of the review was to maximize the efficiency of the manual counting effort for the June 16 data collection. Recognizing that the highest pedestrian volumes were most likely observed on May 26, the data was evaluated to identify count locations that maintained a level of service (LOS) of C. From the Memorial Day Weekend count data, all manual count locations that recorded 200 pedestrians or less during a 15-minute count period and also maintained an acceptable sidewalk LOS of C or better were removed from the counting program for Saturday, June 16. Four manual count locations and one video location were removed from further observation. The locations are identified on Figure 2.10, and included:

- 1 - Luxor Hotel/Casino - Video
- M1 - Tropicana Hotel/Casino
- M2 - Excalibur Hotel/Casino
- M9 - Fontainebleau Hotel/Casino
- M10 - Hilton Grand Vacations

As seen in Figure 2.10, these counting locations are either on the far north or south ends of the study corridor (see Picture 2.26 and Picture 2.27).

The manual data collection effort for the study is summarized below by date and total hours observed for the study.

- Manual Pedestrian Volume Counts

10 locations	5/26/2012	=	120 hours
6 locations	6/16/2012	=	<u>72 hours</u>
			192 hours



Picture 2.26 – Typical Pedestrian Conditions at North end of Study Corridor.

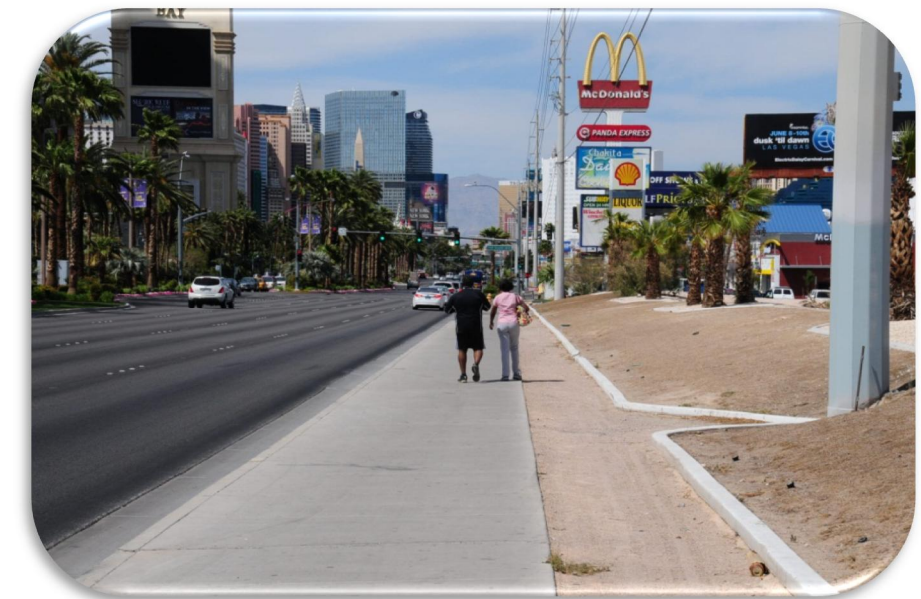

Picture 2.27 – Typical Pedestrian Conditions at South end of Study Corridor.

2.2.3 Pedestrian Walking Speeds

To supplement 2010 HCM methodology for calculating LOS based upon walkway volume, an in-field walking speed study was conducted along the entire length of the study corridor. From the literature review conducted for this study, no research was found that documented the average walking speed of a tourist, or specifically a pedestrian on Las Vegas Boulevard (the "Strip"). To document this walking speed and compare the "perceived level of service" that is provided by the existing walkway conditions, "agents" (walking individuals – see Picture 2.28 and Picture 2.29) were used to collect average walking speeds. The use of the word "agent" in this report refers to a trained engineer who travels in the pedestrian stream and walks with the surrounding pedestrians along the study corridor to collect average walking speed data.

The methodology followed for the pedestrian walking speed field study was adapted from the "Floating-car technique" as described in the Institute of Transportation Engineers "Manual of Transportation Engineering Studies". Using this technique requires that the agent "float" with the pedestrian traffic by safely passing as many pedestrians as pass the agent. The agent is to adjust their personal walking pace to match the individuals around them. This technique best reflects the pedestrian traffic stream under investigation and provides an "average" walking speed.



Picture 2.28 – Pedestrian Agent during Walking Data Collection (west "Strip" northbound).

Walking speed study work sheets were prepared for the study corridor. A set of four worksheets were prepared for the study. The four worksheet sets were organized for walking on either the east or west sides of Las Vegas Boulevard and from starting the walk from either the north or south ends of the study corridor. The clipboard size sheets provided a graphical representation of the walking route, data recording boxes at time points along the walk, and instructions for recording the location of non-permanent

obstructions. A sample walking speed data collection worksheet is shown in Figure 2.11.

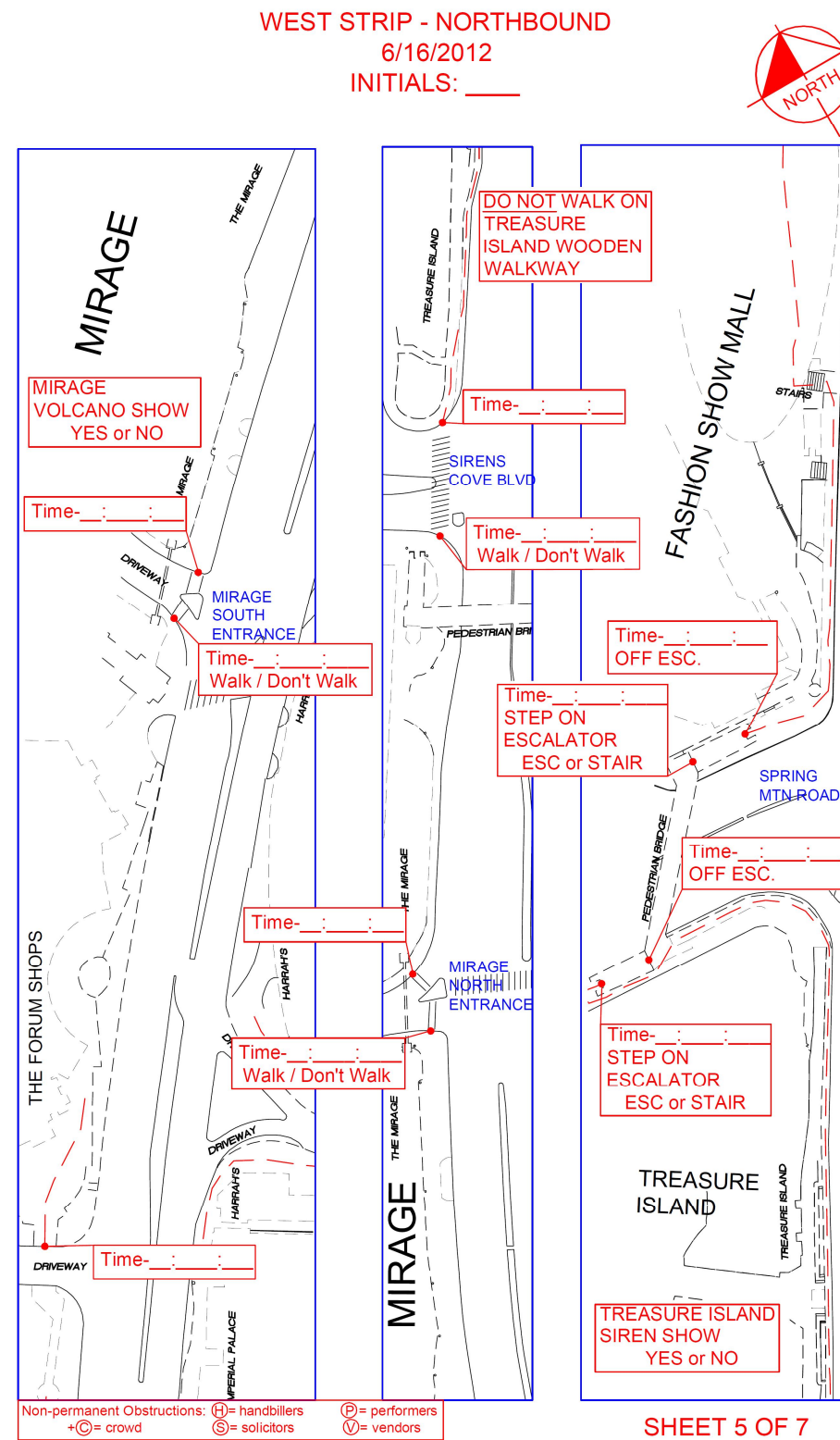

Figure 2.11 – Walking Speed Data Collection Worksheet

At the beginning of each walk, the agent would start a stop watch and record the continuous running clock time at each time point on the data collection form. These time points represented 56 unique locations on the eastside and 55 locations on the west side of Las Vegas Boulevard. The recorded time points and the distance between them determined the walk speeds for various segments of walkway. If needed, for a break, the agent could time themselves out and in to the walking speed study. The east and west sides of the study corridor were separated into segments by the time points. Twenty-five west segments and twenty-eight east segments were identified for the walk study, generally between signalized intersections and across pedestrian bridges (see Figure 2.12).

To conduct the free-flow walking speed study, four agents were used for the Wednesday, April 25 study. At the 9:00 AM start time, two agents began walking north from Russell Road, on each side of Las Vegas Boulevard, and two agents began walking south from Sahara Avenue on each side of Las Vegas Boulevard. The agents recorded their travel time at specified time point locations along the walk. Specific instructions and briefings were provided to each of the agents.



Picture 2.29 – Pedestrian Agent during Walking Data Collection (east "Strip" southbound).

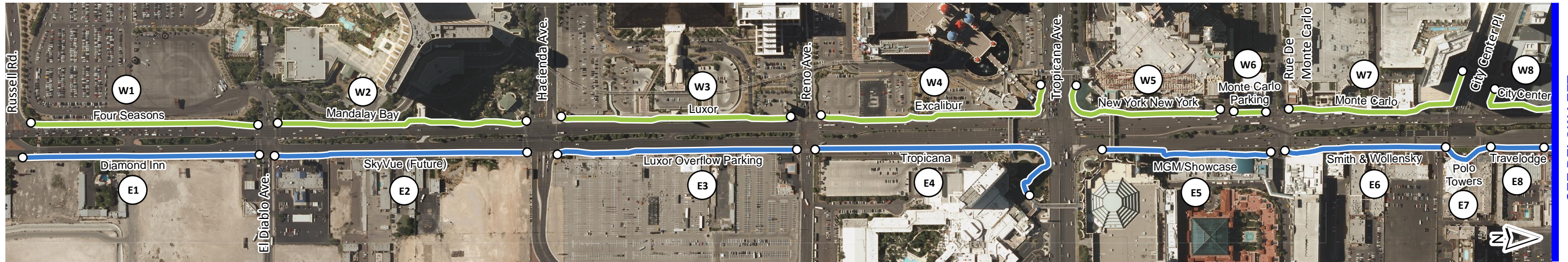

SEE BELOW LEFT



SEE ABOVE RIGHT

SEE RIGHT

SEE LEFT

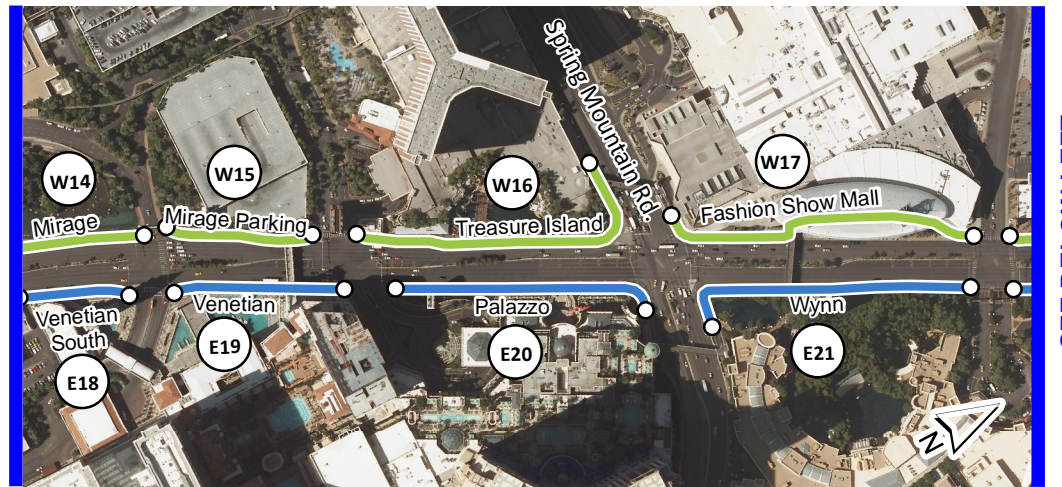

SEE BELOW LEFT



SEE ABOVE RIGHT

Legend

- Segment Limits
- West Segments - 25
- East Segments - 28

WALKING SPEED SEGMENTS

FIGURE 2.12 26

To ensure consistency in the pedestrian walking speed data collection effort, briefing sessions were held with each group of data collection agents prior to commencing the field studies. The following guidance was given to the agents and questions were clarified to ensure a unified approach to the data collection process:

- On the provided data collection worksheet – fill out all corresponding information for the before and after sections prior to beginning and after completing each walk.
- Walk the entire length of the study corridor, between Russell Road and Sahara Avenue.
- Record the time from the stopwatch at each signalized intersection, both upstream and downstream and at other locations specified on the data collection worksheets.
- Do not stop your progress unless continuing would put yourself in danger.
- Safety first. Obey all “DO NOT WALK” signals, even if other pedestrians are not doing so.
- Do not walk up escalators, let them carry you.
- Do not cross Las Vegas Boulevard, remain on your assigned side of the street.
- This is not a race; walk at the same pace as those around you, the data is not about you; it is about the pedestrians/tourists walking along Las Vegas Boulevard.
- If you encounter a stopped crowd (viewing an attraction, etc.), do your best to continue traveling through the crowd (i.e. do not stop to watch the fountains at the Bellagio), but remember to stay on the sidewalk, do not step into the street to pass people, safety first.
- Stay on the public sidewalk – follow the walking paths provided
 - Do not cross the Brooklyn Bridge at the New York-New York
 - Do not enter the roped-off area at Treasure Island
- Follow the floating-agent methodology for walking speed.
- The purpose of the field study is to document the average walking speed of a pedestrian on the Las Vegas Boulevard “Strip” at every location along the “Strip”. Do not walk as fast or as slow as you can, remember the floating-agent technique, if someone passes you, pass someone else and try to be representative of the average pedestrian walking speed.

Following the above methodology and procedure, 12 agents were used to document travel times along the study corridor during peak periods (1:00 PM to 12:00 AM) on Saturday, May 26 (the Saturday of the Memorial Day Holiday weekend) and again on Saturday, June 16 (a non-holiday weekend). To capture walking characteristics during peak pedestrian activity, agents were deployed in each direction (northbound and southbound) on both sides of Las Vegas Boulevard starting at 1:00 PM, 5:00 PM and 9:00 PM. The agents were divided into three four-person teams starting 20 minutes apart from each other. This methodology allowed data to be collected over the span of 60 minutes on both sides of the street in both the northbound and southbound directions. The resulting walking speeds for each segment were calculated and summarized.

2.2.4 Non-Permanent Obstructions

During the peak period walking speed study, non-permanent obstructions were also observed by the 12 walking speed agents. For the study, non-permanent obstructions (obstructive uses) are defined as individuals who could obstruct the pedestrian walkway while hand billing, performing, soliciting or selling. Under County Ordinance 16.11, an “obstructive use” means “obstructing, delaying, hindering, blocking, hampering or interfering with pedestrian passage, including passage to or from private property” (Obstructive Uses of Public Sidewalks - 16.11.020 – General Definitions, Clark County). On May 26 and June 16, the data collection agents were tasked with documenting the quantity, classification and location of non-permanent obstructions in the pedestrian walkway during each of their data collection walks. For the study, non-permanent obstructions were classified into four categories with the following definitions for uniformity in data collection:

- Hand billers – any person within the pedestrian walkway attempting to give away literature of any kind. No financial transaction occurs and the hand biller does not expect anything in return for the literature that is given.
- Performers – any person within the pedestrian walkway attempting to entertain with the expectation of receiving a tip. Performers may include anyone dressed in a costume expecting tips for photographs, or any display of talent for a tip.
- Solicitors – any person within the pedestrian walkway soliciting donations. The solicitor provides nothing to those who donate.
- Vendors – any person within the pedestrian walkway with the intent of selling some item. There is a financial transaction that takes place and some item is exchanged for money.

Picture 2.30 through Picture 2.33 illustrate various activities and their classification. Not all activity was considered to be a non-permanent obstruction as shown in Picture 2.34. Individuals who were stopped in the walkway were not documented as non-permanent obstructions unless they were involved in hand billing, performing, soliciting, or selling. These pictures were used to brief the agents prior to their data collection walks.

Recognizing the twelve walking speed agents collected data only along the north/south walkways and pedestrian bridges of the study corridor, an additional data collector/observer was included in the study to capture information on the east/west pedestrian bridges. The senior engineer assigned to these observations also conducted general observations of the pedestrian activities within the study corridor between Tropicana Avenue and Spring Mountain Road.

The walking speed study work sheets and associated non-permanent obstruction field data as completed by each agent for the study were compiled in the office and summarized in a spreadsheet format. Non-permanent obstructions were summarized by observation period, side of street, and by location within the corridor into the following categories:

- Within 50 feet of an intersection, driveway or crosswalk
- On pedestrian bridges
- Within 15 feet of a pedestrian bridge landing
- Within 15 feet of a bus stop
- Other

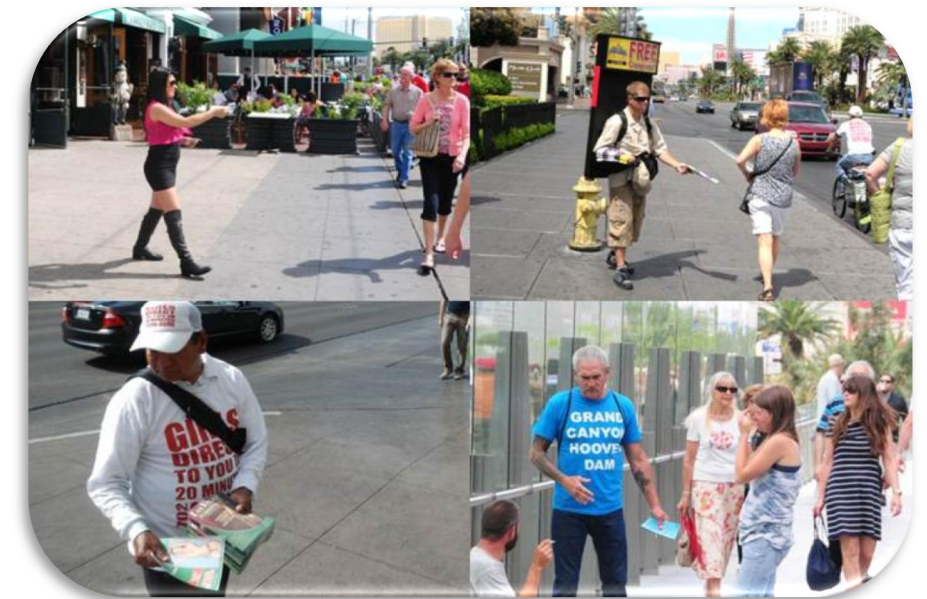

Picture 2.30 – Examples of Hand billers observed on Las Vegas Boulevard.



Picture 2.31 – Examples of Performers observed on Las Vegas Boulevard.



Picture 2.32 – Examples of Solicitors observed on Las Vegas Boulevard.



Picture 2.33 – Examples of Vendors observed on Las Vegas Boulevard.

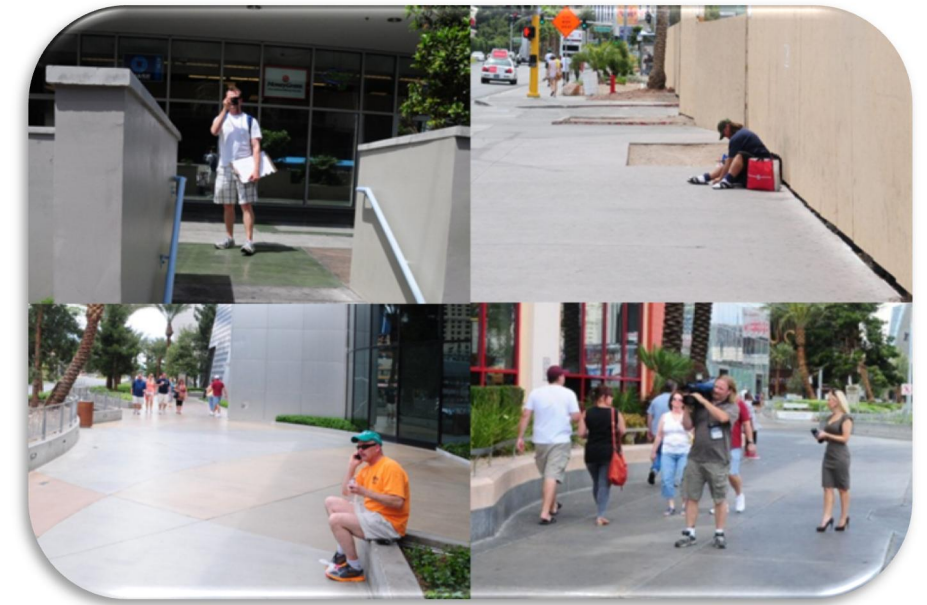

Picture 2.34 – Example of Individuals not considered for this Study as Non-Permanent Obstructions.

2.3 Data Analysis Methodology

This section details the methodology used to analyze the collected pedestrian volume, walking speed, and bus stop queuing data to determine pedestrian Level of Service (LOS) throughout the study corridor.

2.3.1 Pedestrian Volume Analysis – Level of Service Calculations

The 2010 Highway Capacity Manual (HCM) methodology was used for calculating the pedestrian flowrate LOS as used to determine an overall pedestrian level of service along the “Strip”, as well as LOS at specific locations of walkway restrictions (“pinch-points” or “bottlenecks”) along the study corridor. The analysis requires calculation of the following:

1. Determine the effective walkway width (W_E)
2. Calculate the pedestrian flow rate
3. Determine LOS

Determine the effective walkway width (W_E)

The following equation is for the calculation of effective walkway width:

Equation 2.1 – Effective Walkway Width (W_E)

$$W_E = W - W_o$$

where: W_E = effective walkway width (ft),

W or W_T = total walkway width at a given point along walkway (ft), and

W_o = sum of fixed-point object effective widths and linear-feature shy distances at a given point along walkway (ft).

The total walkway widths (W or W_T) for Equation 2.1 and the factors that influence the determination of the effective walkway widths (W_E) in Equation 2.1 were found using a combination of aerial imagery, available topographic surveys and field measurements. The 2010 HCM defines effective walkway width (W_E) as:

“the portion of a walkway that can be used effectively by pedestrians. Various types of obstructions and linear features... reduce the walkway area that can be effectively used by pedestrians... Linear features such as the street curb, [a] low wall, [or a] building face each have associated shy distances. The shy distance is the buffer that pedestrians give themselves to avoid accidentally stepping off the curb, brushing against a building face, or getting too close to other pedestrians standing under awnings or window shopping. Fixed objects, such as [a] tree, have effective widths associated with them. The fixed-object effective width includes the object’s physical width, any functionally

unusable space (e.g., the space between a parking meter and the curb of the space in front of a bench occupied by people’s legs and belongings), and the buffer given the object by pedestrians” (pg. 23-9, 2010 HCM).

The 2010 HCM recommends that walkway operational analysis evaluate “the portion of the walkway with the narrowest effective width (W_E), since this section forms the constraint on pedestrian flow” (pg. 23-10, 2010 HCM). Figure 2.13 shows graphically how effective walkway width (W_E) is calculated (adapted from the 2010 HCM).

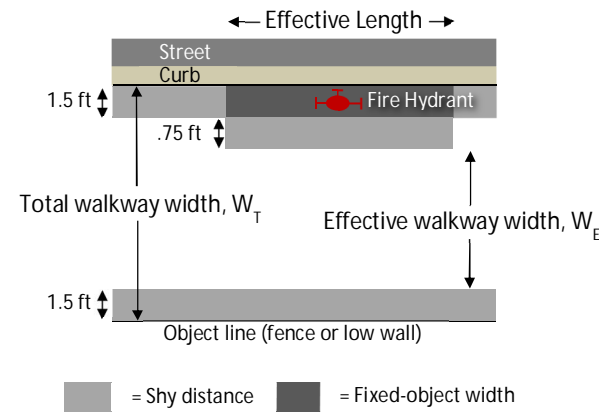

Figure 2.13 – Effective Walkway Width (W_E) Diagram

Table 1.2 as presented in Section 1.4.1 of the study, summarizes the HCM recommended effective width of various objects. The summation of the shy distances from each object within a cross section of walkway is subtracted from the total walkway width (W) to determine the effective walkway width (W_E) for that section of walkway.

The effective walkway widths (W_E) for the study corridor were calculated at each pedestrian volume count location and for restricted sidewalk locations as identified during the field inventory of the study corridor. The typical effective walkway widths (W_E) on the east and west sides of Las Vegas Boulevard as summarized in Figure 2.1 were geocoded in a Graphical Information System (GIS) database.

Using Equation 2.2, the walkway characteristics for the observed pedestrian volumes can be used to determine the walkway level of service.

Equation 2.2 – Pedestrian Flow Rate per Unit Width of Walkway

$$v_p = \frac{v_{15}}{15 \times W_E}$$

where: v_p = pedestrian flow per unit width (p/ft/min),

v_{15} = pedestrian flow rate during peak 15 min (p/h), and

W_E = effective sidewalk width (ft).

Table 2.2 from the 2010 HCM shows the level of service threshold criteria for pedestrian flowrates.

Table 2.2 – Pedestrian Level of Service

LOS	Flow Rate (p/min/ft)	Comments
A	≤5	Ability to move in desired path, no need to alter movements
B	>5 - 7	Occasional need to adjust path to avoid conflicts
C	>7 - 10	Frequent need to adjust path to avoid conflicts
D	>10 - 15	Speed and ability to pass slower pedestrians restricted
E	>15 - 23	Speed restricted, very limited ability to pass slower pedestrians
F	Variable	Speeds severely restricted, frequent contact with other users

To estimate the level of service for the sidewalks along Las Vegas Boulevard for the entire study corridor, the observed pedestrian flow rates were interpolated between data collection sites. Using computational spreadsheets to support a GIS database, the resulting sidewalk levels of service (LOS) were calculated for the two Saturdays of observation and for various times of day. Effective walkway width (W_E) calculations summarized in Figure 2.1 did not consider or include and potential reduction in walkway width due to non-permanent obstructions or bus stop queues. The LOS calculations are based on the existing walkway width less permanent obstructions. This approach allows for the calculation of the study corridor walkway level of service (LOS) without the variable impacts from non-permanent obstructions.

2.3.2 Walking Speed Analysis Methodology

Each walking speed data point collected by the agents was imported into Excel spreadsheets and analyzed to find the average walking speed for each segment of the study corridor. The free-flow walking speed, established during uncongested conditions, allowed for a comparison of each walkway segment through a range of pedestrian activity levels. Average walking speeds were also identified for each of the pedestrian bridges. The walking speed data on both the east and west sides of Las Vegas Boulevard were analyzed to identify variations in walking speeds. Overall walking speeds were evaluated to determine which segments of the study corridor may experience LOS less than C. With the determination of walking speeds by segment, the walking LOS can be categorized using the 2010 HCM. The HCM defines a walking speed LOS based upon the values in Table 2.3.

Table 2.3 – LOS and Average Speed Values

LOS	Average Speed (ft/s)	Comments
A	> 4.25	Ability to move in desired path, no need to alter movements
B	> 4.17 - 4.25	Occasional need to adjust path to avoid conflicts
C	> 4.0 - 4.17	Frequent need to adjust path to avoid conflicts
D	> 3.75 - 4.0	Speed and ability to pass slower pedestrians restricted
E	> 2.5 - 3.75	Speed restricted, very limited ability to pass slower pedestrians
F	≤ 2.5	Speeds severely restricted, frequent contact with other pedestrians

The walking speeds on the east and west sides of the “Strip” for the 1:00 PM period, 5:00 PM period, and 9:00 PM period were imported into GIS. Within GIS, the data was analyzed to create visual representations of the data at different times of day along the Resort Corridor. The use of GIS allowed the analysis to be performed continuously from Russell Road to Sahara Avenue on both sides of Las Vegas Boulevard displaying average pedestrian walking speeds for each walkway segment.

The following section details the statistical analysis of the walking speed data for use in determining a walking speed LOS.

Statistical Analysis

A t-test statistical analysis with a 95% confidence level was conducted and found that northbound travel and southbound travel were not statistically different. The same analysis of the east “Strip” and west “Strip” showed a statistical difference in walking speeds. These conclusions allowed the analysis of the walking data to be aggregated into east “Strip” walking speeds and west “Strip” walking speeds as no difference in northbound and southbound travel was found for either side of the “Strip”.

Data Aggregation

The statistically supported aggregation of northbound and southbound walking speed data allowed each segment walking speed to be averaged between six agents’ observed speeds on each side of the “Strip” in each data collection time. To illustrate, while 12 agents collected walking speed data between 1:00 PM and 4:00 PM, the aggregated data provides two representative samples, one for each side of the “Strip” (east and west). Aggregating the data is beneficial in representing the average walking speed as outliers and individual interpretation of the agents is combined. Along with average walking speeds at each point along the Resort Corridor, an overall “tourist” walking speed on the “Strip” was calculated using the data from 12 agents at three times throughout the day on two data collection Saturdays (May 26 and June 16, 2012).

2.3.3 Bus Stop Queuing Analysis Methodology

As of June 16, 2012, there were 29 bus stops on Las Vegas Boulevard in the Resort Corridor between Russell Road and Sahara Avenue (15 southbound and 14 northbound). Figure 2.6 shows the locations of the 29 bus stops. An analysis was conducted for bus stop queuing using the following methodology.

Ridership data was provided by the Regional Transportation Commission of Southern Nevada (RTC) for both Saturday, May 26, 2012 and Saturday, June 16, 2012. This ridership data was an aggregation of the two transit lines that serve the Resort Corridor (“DEUCE on The Strip” and “Strip & Downtown Express - SDX”). The express bus utilizes only four stops in the southbound direction and four stops in the northbound direction while the DEUCE stops at each of the 15 southbound stops and 14 northbound stops. Table 2.4 lists the stops shared between the two transit lines:

Table 2.4 – Shared Bus Stops within Resort Corridor

Southbound	Northbound
Fashion Show Mall	Wynn
Bellagio	Paris
Excalibur	Showcase Mall/MGM Grand
Mandalay Bay	Mandalay Bay

The DEUCE operates on headways between 12 and 15 minutes from 7:00 AM to 11:30 PM and the SDX runs on 12-15 minute headways between 9:00 AM and 10:30 PM. The aggregated data from the RTC was collected in 15 minute time increments and was separated into bus boardings and alightings. This data was used to determine the maximum number of bus riders queued at each of the 29 bus stops by using the maximum boardings in a 15 minute time period.

The maximum boardings were then used to determine the space required to provide a LOS C or better queuing area based on the 2010 HCM queuing space requirements.

2.4 Pedestrian Simulation Model

To more fully understand the impact of obstructions to the LOS provided by Las Vegas Boulevard, pedestrian simulation modeling was used. An analysis of the collected data revealed certain areas of concern and interest for inclusion in the simulation models. Simulation models at four locations were created to simulate the effects of an obstruction on the pedestrian flows.

2.4.1 Model Background

In order to analyze various walkway segments with and without obstructions, the Advanced Land-Transportation Performance Simulation™ (ALPS™) software was utilized. ALPS™ is a suite of modeling and analysis programs that have been under development by Kimley-Horn and Associates, Inc., for over 30 years and allows the modeler to create simulations that encompass the various pedestrian and vehicular movements within a multi-modal transportation environment. ALPS embodies a unique demand modeling and operational analysis system that has been developed for studies of airport environments, multimodal travel corridors, transportation systems, urban districts/major activity centers, and intermodal facilities.

ALPS is an integrated suite of computer programs that have been created and applied with a “systems engineering” perspective, meaning that the multimodal systems that are modeled are viewed as interrelated subsystems. The ALPS model is demand driven, with activity generated based on pedestrian data. ALPS™ simulates pedestrian activity based on pedestrian volumes, speeds, and group size, among other variables. The assembly of roadways, curbs, parking facilities, transit systems, pedestrian walkways, elevators, ticket processing counters, security screening points, concession areas, and other such subsystems can all be simulated to study how changes to one subsystem affect the performance and operation of all other subsystems.

ALPS has been used for numerous types of projects throughout the United States (i.e., baseball stadiums, casinos, airports, downtown environments, etc.) for detailed modeling of transportation operations (including roadways, terminal curbs, ground transportation centers, rental car facilities, and parking facilities), terminal operations and planning, and transit system evaluation and operational analysis. The latest ALPS models include animations which provide great benefit in communicating alternatives to clients and other stakeholders.

2.4.2 Model Methodology

The pedestrian volumes were used along with the geometric constraints of each location to provide a visual and mathematical model of pedestrian movement within the study corridor at walkway segments of interest. For each of the four models differing scenarios were contemplated, with no obstructions and with obstructions. Conservative analysis assigned a 2.25-foot reduction to the effective walkway width at each location for an obstruction.

3 DATA EVALUATION

Quantitative and qualitative measures are important when addressing safety concerns and general experience enhancements. This section of the report presents both the numerical results from the data collection effort, as well as the qualitative assessments made by Kimley-Horn and Associates staff.

Numerical results are provided for the data collection and analysis with regard to pedestrian volumes from the video and manual counts and resulting level of service values along the entire study corridor from Russell Road to Sahara Avenue. The results from the pedestrian walking speed study and non-permanent obstructions data collection are also presented. In addition, bus stop queuing analysis results are summarized, along with a discussion on the results of the pedestrian simulation models and their implications.

3.1 Pedestrian Volumes

The pedestrian volume data from each count location was evaluated and plotted graphically to show peak periods of pedestrian traffic and identify maximum volumes. (The pedestrian volume data collected for this study is included on a CD at the back of the report.)

Figure 3.1 and Figure 3.2 show a summary of the maximum 15-minute pedestrian volumes at each count location from the Luxor Hotel/Casino near the south end of the study area and continuing to the Hilton Grand Vacations near the north end of the study area on the Memorial Day weekend holiday Saturday and a typical Saturday respectively.

The individual count location data was separated into three sections for ease of data comparison as follows:

- Outer Study Area (Russell Road – Flamingo Road and Spring Mountain Road – Sahara Avenue)
(see Figure 3.4 through Figure 3.12)
- Inner Study Area (Flamingo Road – Spring Mountain Road)
(see Figure 3.13 through Figure 3.27)
- Pedestrian Bridges
(see Figure 3.28 through Figure 3.41)

Figure 3.4 and Figure 3.41 provide a visual summary of the maximum 15-minute pedestrian volume at each count location for each count day (May 26 and June 16, 2012).

In determining the pedestrian volumes, individuals using wheel chairs, scooters or walkers were categorized as “assisted walkers”. This was done to document the number of assisted walkers in the pedestrian stream. Evaluation of the data showed that a limited number of pedestrians were assisted walkers. For example, the 24-hour count conducted at the Bally’s Plaza recorded 99,346 pedestrians of which 46 were assisted walkers or 0.05% of the daily volume (and only 0.17% of the peak hour volume). The maximum number of assisted walkers (see Picture 3.1) observed within the

collected data set for a 15-minute period was a total of three. Although the percentage of assisted walkers was found to be minimal, their presence demonstrates the importance of providing accessible walkways. The walking speed analysis was not adjusted to reflect assisted walkers as they are not expected to cause significant walking speed level of service reductions. Assisted walkers are included in the reported total pedestrian volumes.

The maximum number of pedestrians observed in a 15-minute period was 2,633 between Bellagio South and the Cosmopolitan Hotel/Casino during the time of 9:30 PM and 9:45 PM on Saturday, May 26, 2012 of Memorial Day weekend. The east side of Las Vegas Boulevard was found to have a maximum 15 minute pedestrian volume of 2,124 in front of the Paris Hotel/Casino between 4:00 PM and 4:15 PM also on Saturday, May 26, 2012. A total of 11 (of 38) locations were observed with more than 1,500 pedestrians in 15-minutes on May 26, 2012. This is compared to a total of 5 (of 32) locations observed with more than 1,500 pedestrians in 15-minutes during June 16, 2012. A maximum volume of 1,500 pedestrians in 15 minutes represents a pedestrian LOS C on an effective width walkway of 10 feet.



Picture 3.1 – Assisted Walker.

3.1.1 Evaluation Summary

Generally, on the holiday Saturday of May 26, 2012, a LOS of B or better was provided in the outer areas of the study corridor from Russell Road to Tropicana Avenue and from Spring Mountain Road to Sahara Avenue. The following evaluation is based solely on the volume at each count location and the associated walkway widths at those locations. Within the inner portion of the study corridor, from Tropicana Avenue to Spring Mountain Road the LOS calculations generally showed that the walkways provided a pedestrian volume LOS C or better except for the following count locations:

- Metro1 – Harley Davidson Cafe – LOS E
- 11 – Flamingo Road West Pedestrian Bridge – LOS D
- 12 – Flamingo Hotel/Casino – LOS D
- M6 – Caesars Palace Hotel/Casino – LOS D
- 13 – Forum Shops – LOS D
- 14 – Harrah’s Hotel/Casino – LOS D
- 15 – Mirage Hotel/Casino – LOS E
- CC3 – Venetian Hotel/Casino – LOS E

It is important to note that the LOS evaluation and the associated figures (Figure 3.4 through Figure 3.41) were completed assuming the full effective walkway width (W_E) was available for pedestrian traffic. When a non-permanent obstruction is present, the effective walkway width (W_E) is reduced and the LOS of the walkway can also be reduced. In some cases, the LOS F threshold can be exceeded for the observed pedestrian volumes. With the presence of one non-permanent obstruction standing on the side of the walkway within the pedestrian flow, a reduction of 2.25 feet from the effective walkway width (W_E) was applied. Under these conditions the following count locations were calculated to degrade to LOS F:

- Metro 1 – Harley Davidson Cafe
- CC3 – Venetian Hotel/Casino
- CC4 – Treasure Island Hotel/Casino

Weeklong Data

Figure 3.3 summarizes the weekly and hourly count data collected within the study corridor. As illustrated in the figure, the day of week and average hourly variations are generally consistent with the findings from the Caesars International year-long study in front of the Imperial Palace Hotel/Casino. The exception is that Monday was found to have less pedestrian volume and was found to be similar to Tuesday, Wednesday, or Thursday daily pedestrian volumes for the average data collected at six locations from Tropicana Avenue to Spring Mountain Road. The additional daily count data at multiple locations within the study corridor confirms the Caesars International data to be reasonably representative of the study corridor.

Typical Saturday

Data collected on the typical Saturday (June 16, 2012) showed similar characteristics as the data collected on the holiday Saturday (May 26, 2012). The main distinction between the two days was that the total pedestrian volumes on the typical Saturday were generally lower than those of the holiday Saturday. The pedestrian volume peaking hourly trends were generally the same and in many cases the maximum peak 15-minute period at a count location was observed at the same time of day.

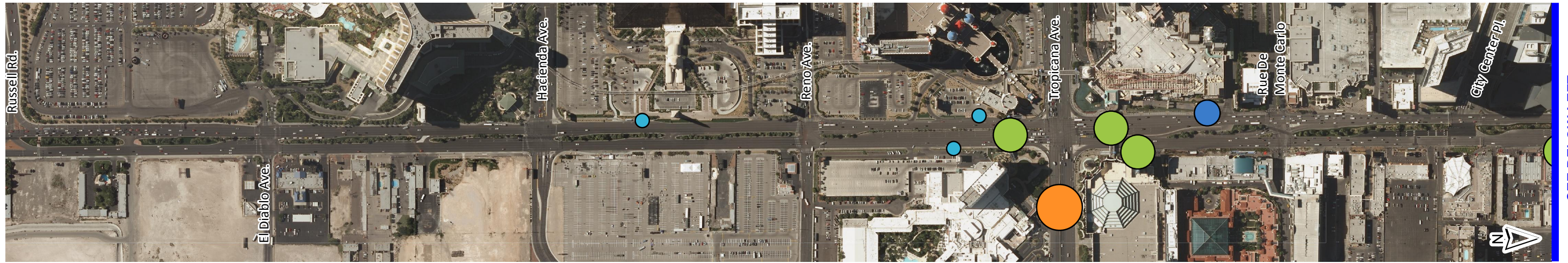

SEE BELOW LEFT

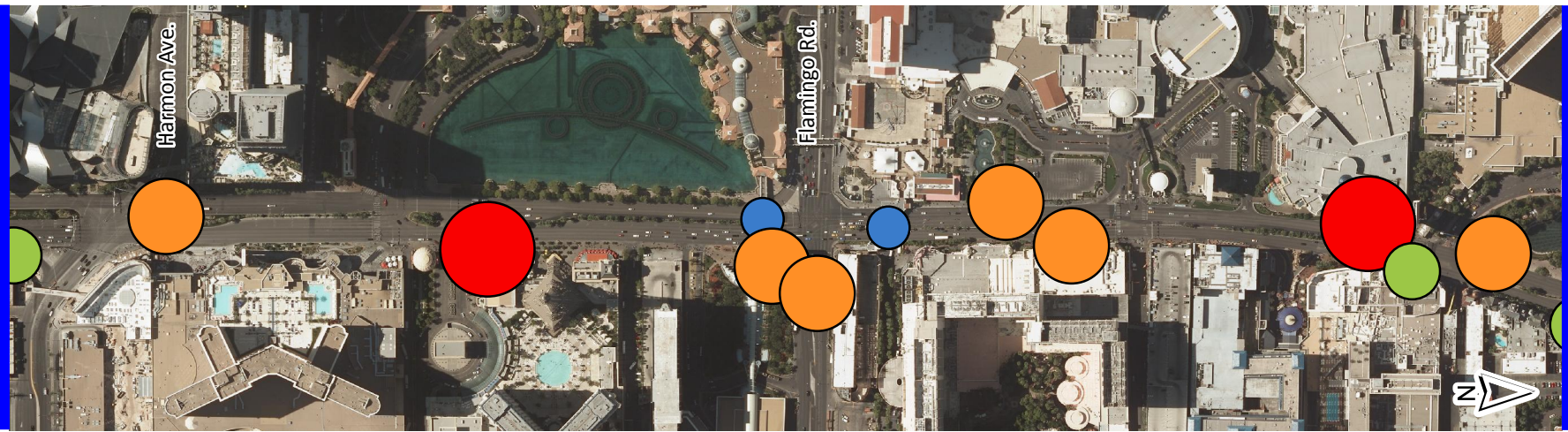

SEE ABOVE RIGHT

SEE RIGHT

SEE LEFT

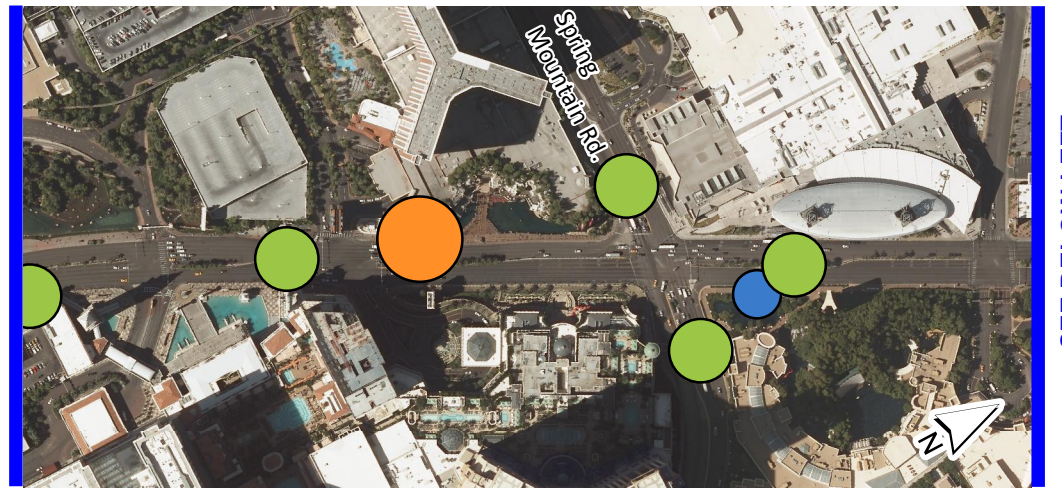

SEE BELOW LEFT

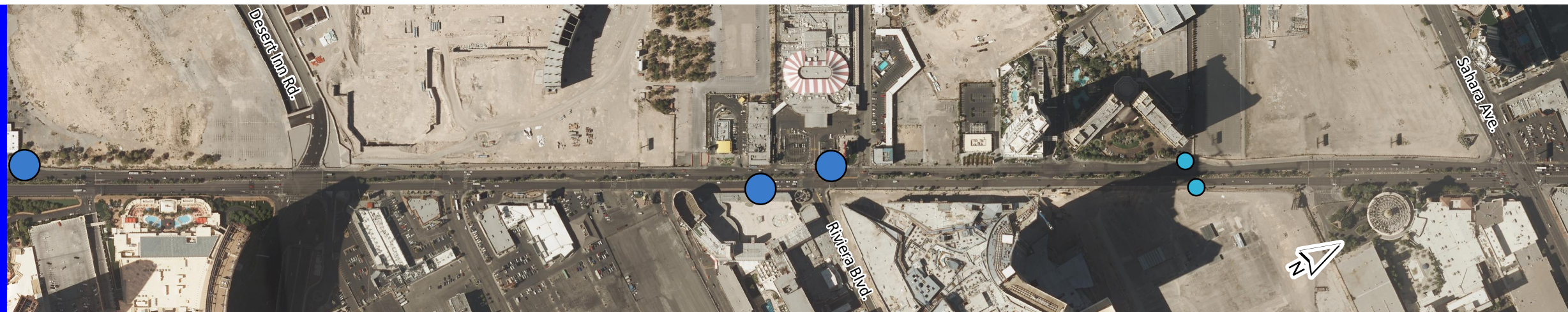

SEE ABOVE RIGHT

Legend

Max. 15-Minute Pedestrian Volume at Count Locations

- 200 or Less
- 201 - 800
- 801 - 1,400
- 1,401 - 2,000
- Greater than 2,000

**PEDESTRIAN VOLUME - MAX 15 MINUTES
MAY 26, 2012**

FIGURE 3.1 32

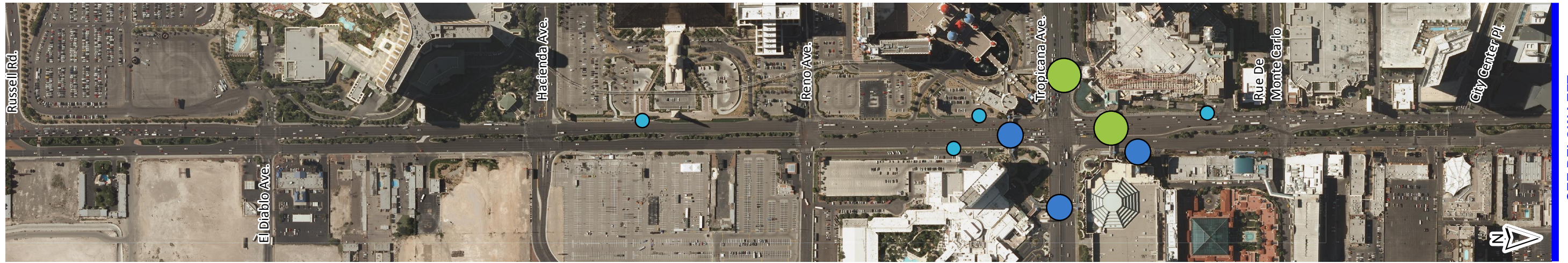

SEE BELOW LEFT



SEE ABOVE RIGHT

SEE RIGHT

SEE LEFT

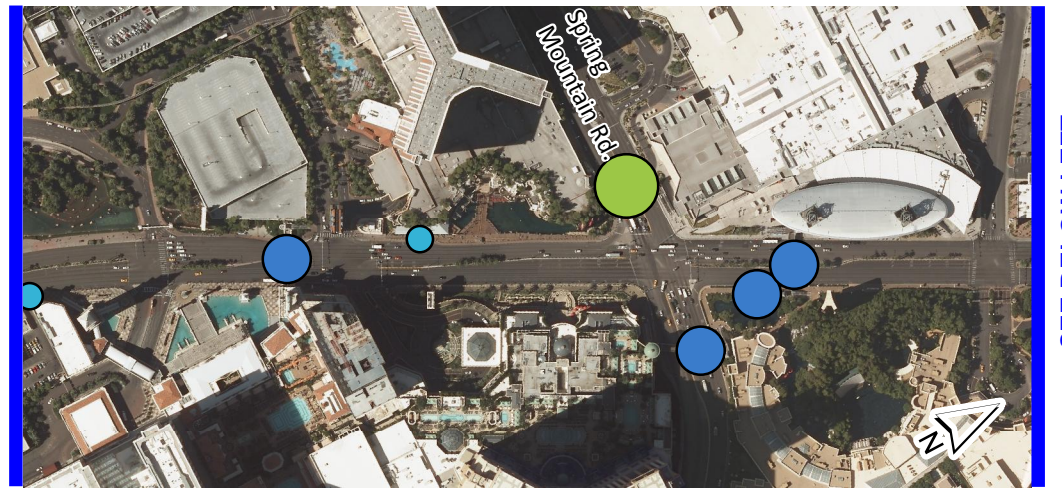

SEE BELOW LEFT

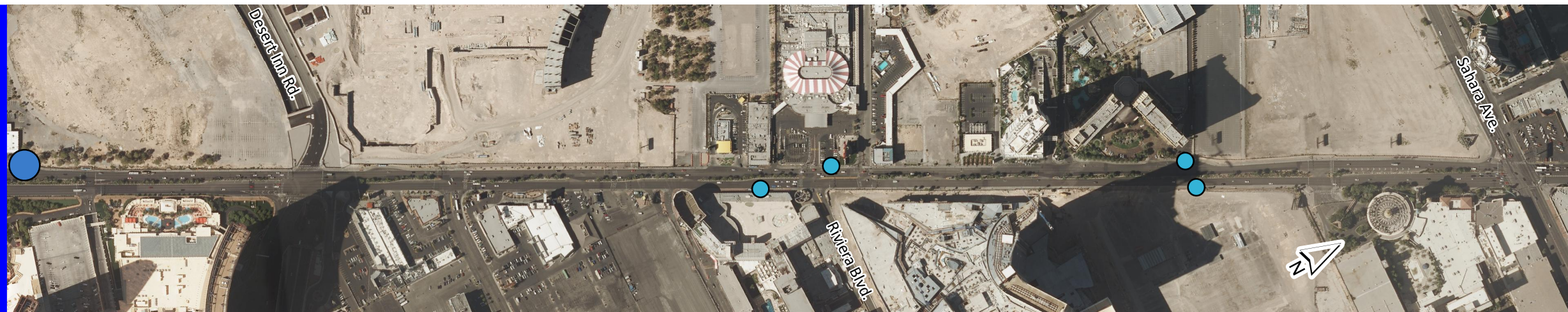

SEE ABOVE RIGHT

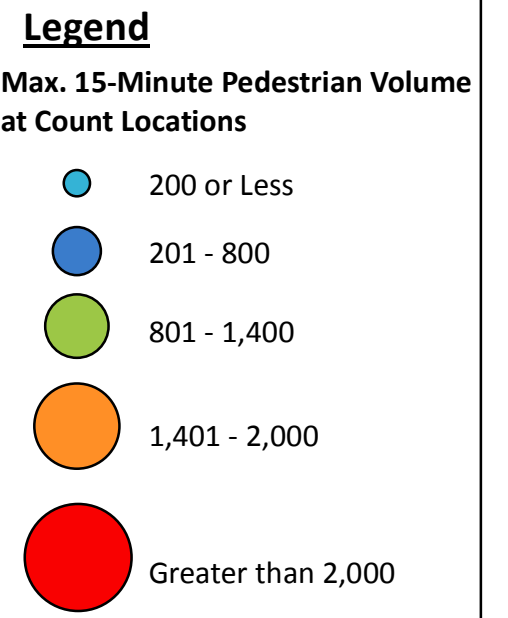

PEDESTRIAN VOLUME - MAX 15 MINUTES
JUNE 16, 2012

FIGURE 3.2 33

Imperial Palace Hotel/Casino - Average Observed Daily Pedestrians by Day of Week

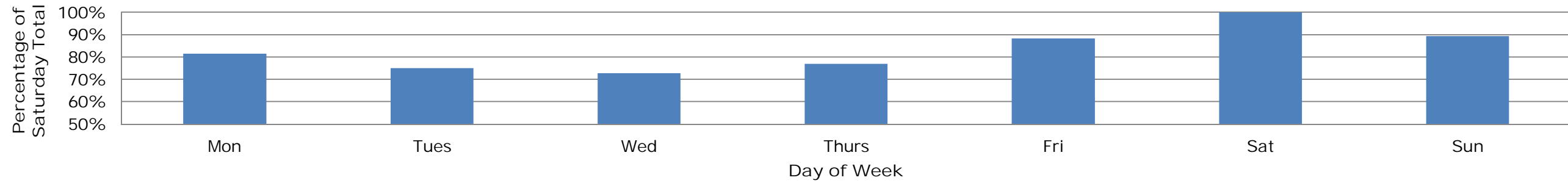

Tropicana Avenue to Spring Mountain Road - Average Observed Daily Pedestrians by Day of Week

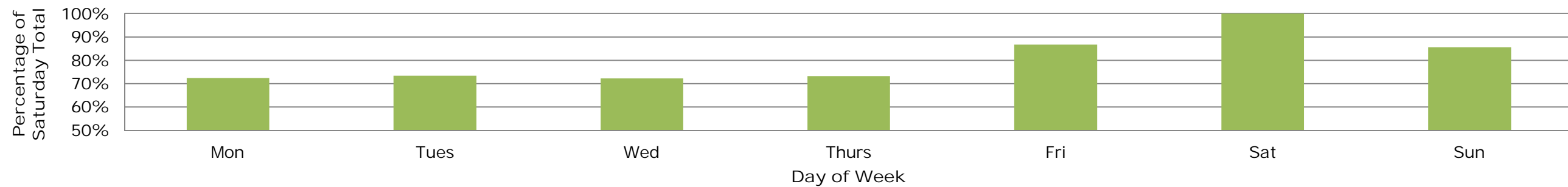

Imperial Palace Hotel/Casino - Average Observed Pedestrians per 15-Minutes by Time

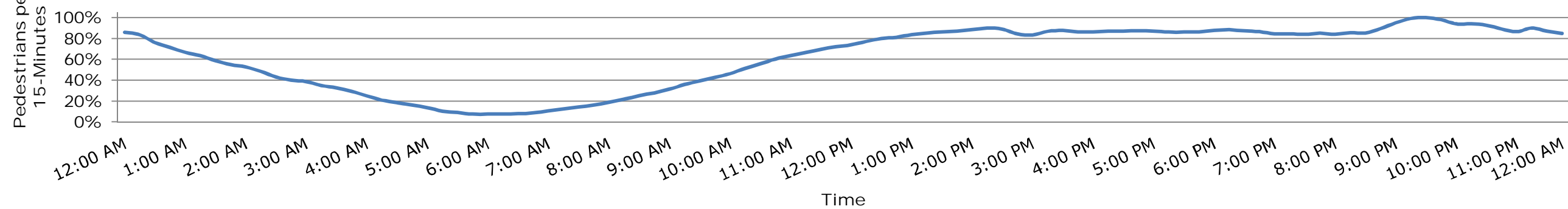

Tropicana Avenue to Spring Mountain Road - Average Observed Pedestrians per 15-Minutes by Time

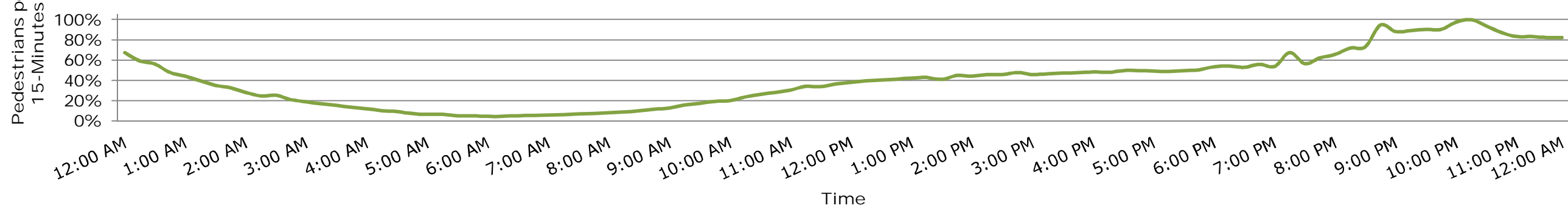

PEDESTRIAN VOLUME TREND COMPARISON

FIGURE 3.3

3.1.2 Outer Portion of the Study Corridor

The pedestrian volumes within the outer portion of the study corridor (Russell Road to Tropicana Avenue and Spring Mountain Road to Sahara Avenue) were generally lower than the inner portion. The maximum 15-minute pedestrian volume observed south of Tropicana Avenue was 200 at the Excalibur Hotel/Casino and the maximum north of Spring Mountain Road was 341 at the Riviera Hotel/Casino. The existing walkway widths adequately serve the observed pedestrian volumes in these areas. An acceptable LOS of B or better was observed throughout the outer portion of the study corridor throughout all of the study observations. Picture 3.2 and Picture 3.3 show the typical conditions of the outer portion of the study corridor.

Data was collected at a total of nine locations in the outer portion of the study area, which were:

- 1 – Luxor Hotel/Casino - Figure 3.4
- M1 – Tropicana Hotel/Casino - Figure 3.5
- M2 – Excalibur Hotel/Casino - Figure 3.6
- 18 – Wynn Hotel/Casino - Figure 3.7
- M8 – North of Fashion Show Drive - Figure 3.8
- 20 – Riviera Hotel/Casino - Figure 3.9
- 21 – Circus Circus Hotel/Casino - Figure 3.10
- M9 – Fontainebleau Hotel/Casino - Figure 3.11
- M10 – Hilton Grand Vacations - Figure 3.12

Table 3.1 summarizes the maximum 15-minute pedestrian volumes and the LOS for each count location on both the Holiday and Typical Saturday. As discussed in Section 2.2.2, count locations with a maximum 15-minute pedestrian volume less than 200 were not counted on the typical Saturday. Pedestrian volumes data was collected on both May 26 and June 16, 2012 at the following locations:

- 18 – Wynn Hotel/Casino
- M8 – North of Fashion Show Drive
- 20 – Riviera Hotel/Casino
- 21 – Circus Circus Hotel/Casino

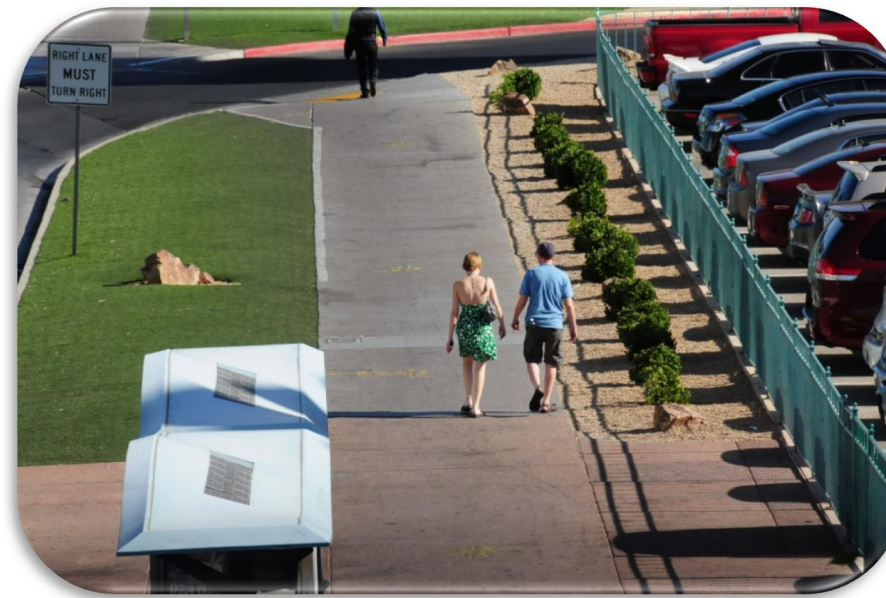

Picture 3.2 – Typical Pedestrian Activity on South end of Study Corridor.



Picture 3.3 – Typical Pedestrian Activity on North end of Study Corridor.

Table 3.1 – Data Summary for Outer Portion of the Study Corridor

Holiday Saturday - May 26, 2012											
West Side						East Side					
ID	Name	W _E	Max 15-min Volume	Time of Max Volume	LOS	ID	Name	W _E	Max 15-min Volume	Time of Max Volume	LOS
1	Luxor	7.0	121	12:15PM - 12:30PM	A	M1	Tropicana	3.5	68	11:00PM - 11:15PM	A
M2	Excalibur	9.8	200	10:45PM - 11:00PM	A	18	Wynn	11.8	264	12:30AM - 12:45AM	A
M8	N of Fashion Show	3.2	312	10:15PM - 10:30PM	B	20	Riviera	13.8	341	8:45PM - 9:00PM	A
21	Circus Circus	8.7	216	9:45PM - 10:00PM	A	M9	Fontainebleau	5.3	129	5:30PM - 5:45PM	A
M10	Hilton Grand	6.7	75	4:30PM - 4:45PM	A						

Typical Saturday - June 16, 2012											
West Side						East Side					
ID	Name	W _E	Max 15-min Volume	Time of Max Volume	LOS	ID	Name	W _E	Max 15-min Volume	Time of Max Volume	LOS
M8	N of Fashion Show	3.0	262	10:15PM - 10:30PM	B	18	Wynn	11.8	324	12:00AM - 12:15AM	A
21	Circus Circus	8.7	201	10:00PM - 10:15PM	A	20	Riviera	13.8	187	9:15PM - 9:30PM	A

Luxor Hotel/Casino (Location ID: 1)
 Video Count Location: 2,040 ft. South of Tropicana Avenue
 Walkway Width (W) = 10 feet
 Effective Walkway Width (W_E) = 7 feet

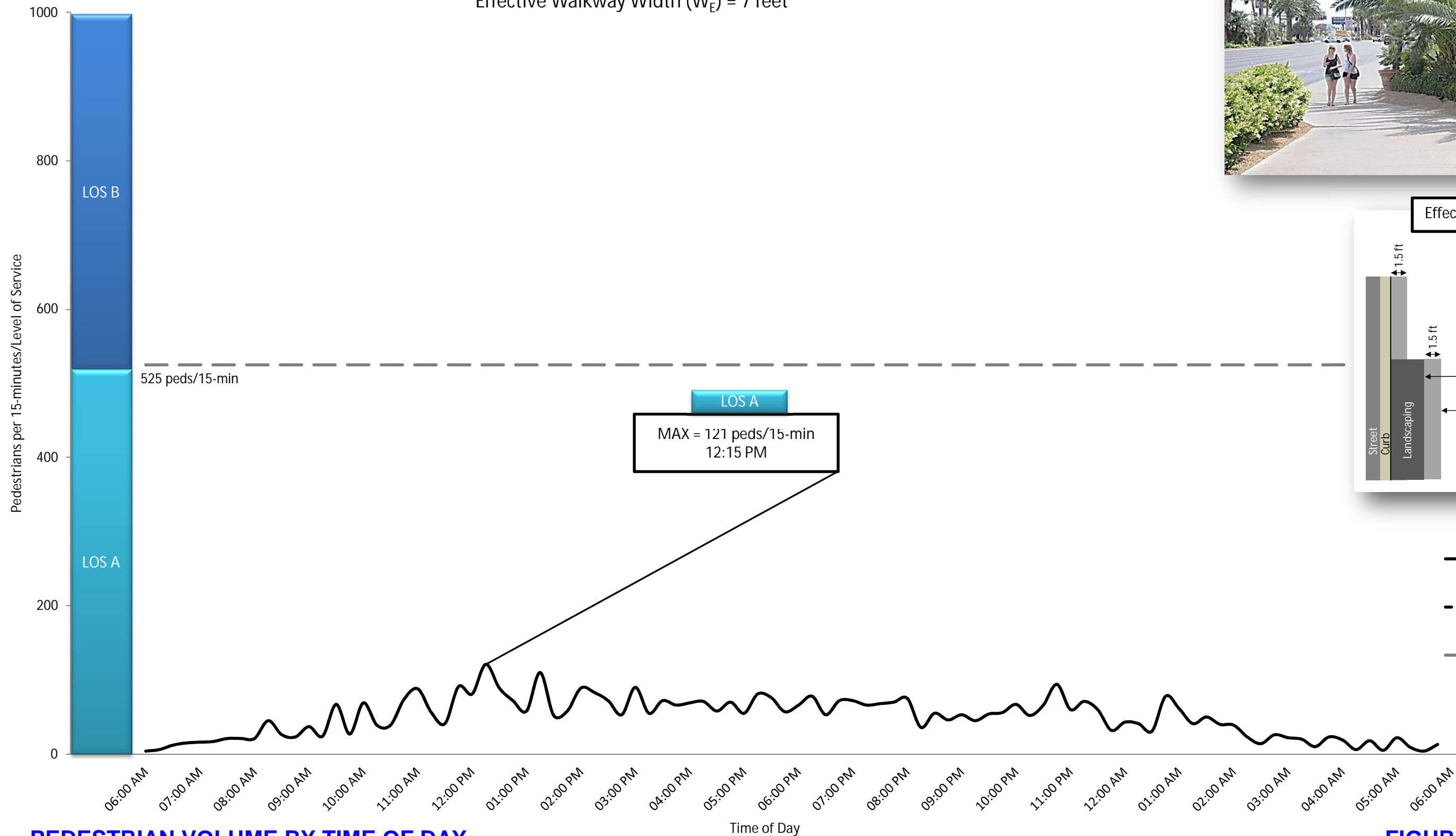
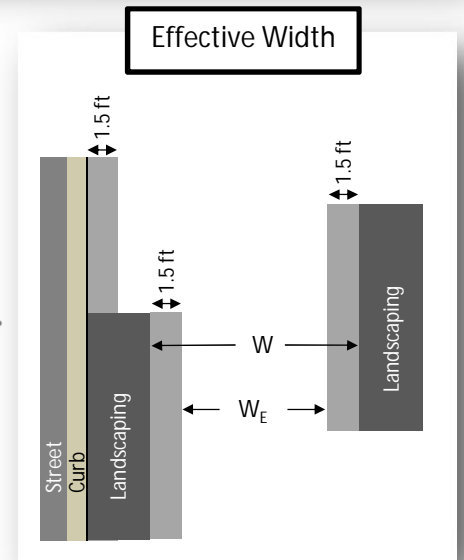

PEDESTRIAN VOLUME BY TIME OF DAY

Tropicana Hotel/Casino (Location ID: M1)
 Manual Count Location: 530 ft. South of Tropicana Avenue
 Walkway Width (W) = 5.8 feet
 Effective Walkway Width (W_E) = 3.5 feet

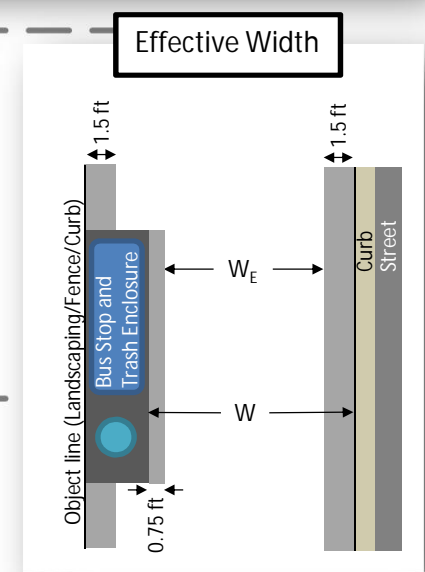
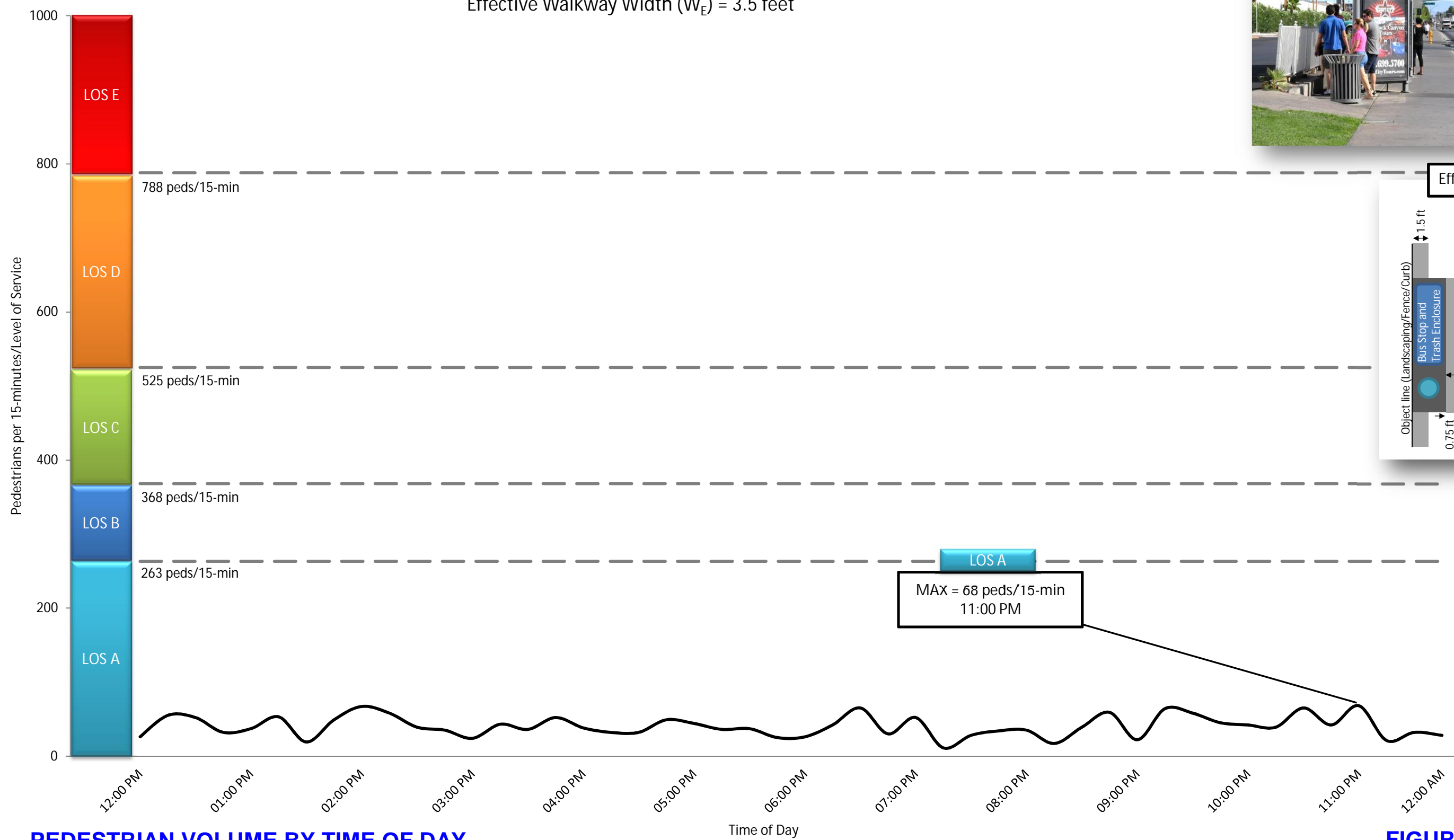

PEDESTRIAN VOLUME BY TIME OF DAY

Excalibur Hotel/Casino (Location ID: M2)
 Manual Count Location: 370 ft. South of Tropicana Avenue
 Walkway Width (W) = 12 feet
 Effective Walkway Width (W_E) = 9.8 feet

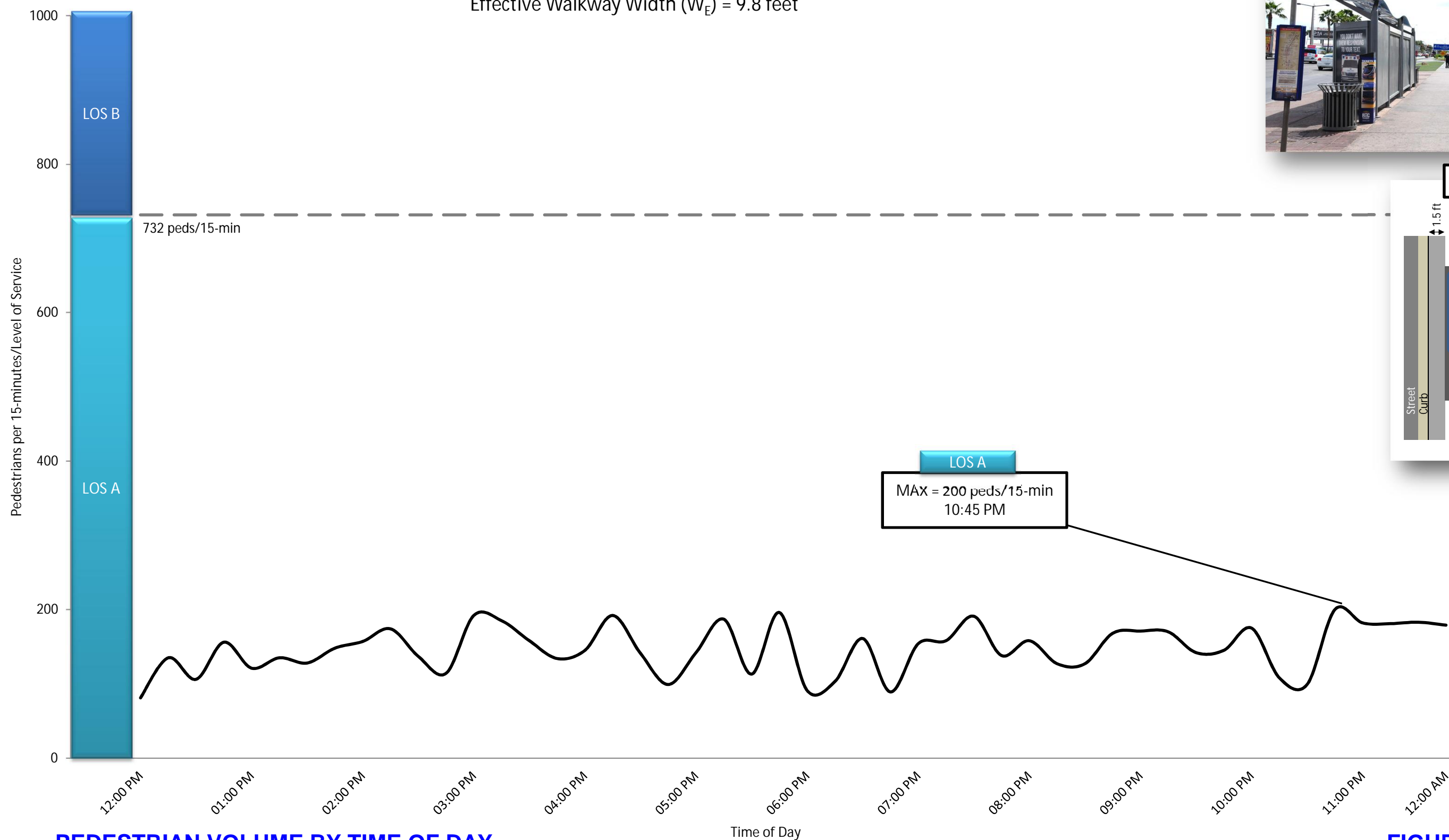
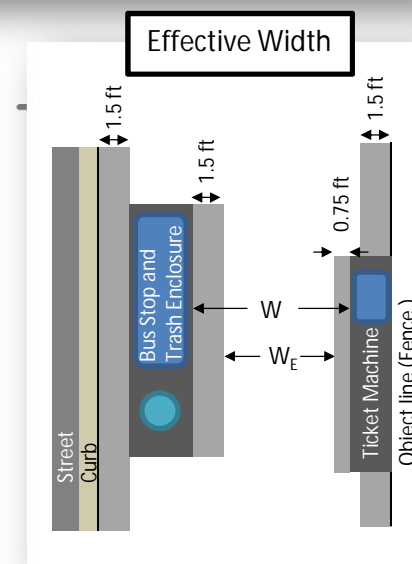

PEDESTRIAN VOLUME BY TIME OF DAY

FIGURE 3.6

Wynn Hotel/Casino (Location ID: 18)
 Video Count Location: 390 ft. North of Spring Mountain Road
 Walkway Width (W) = 14.8 feet
 Effective Walkway Width (W_E) = 11.8 feet

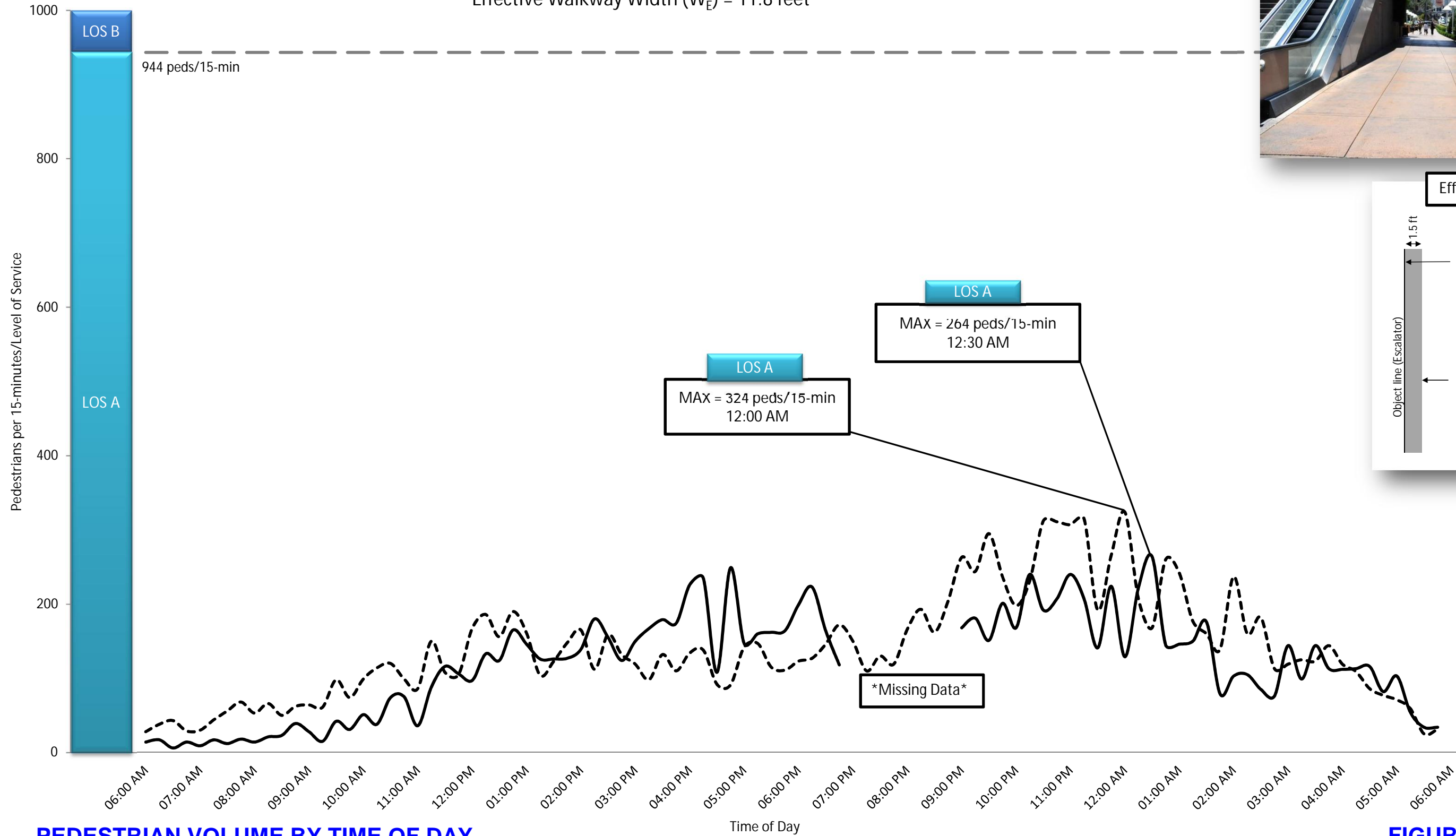
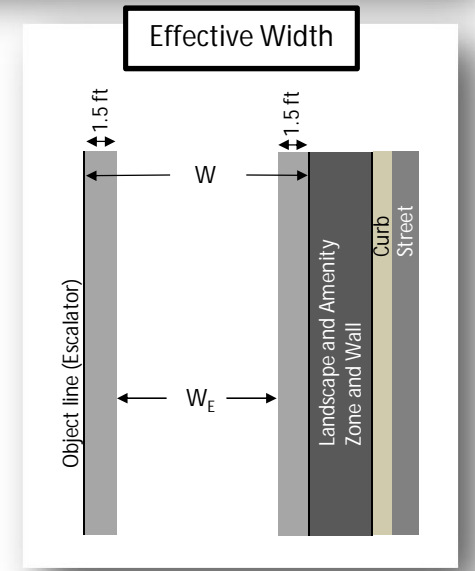
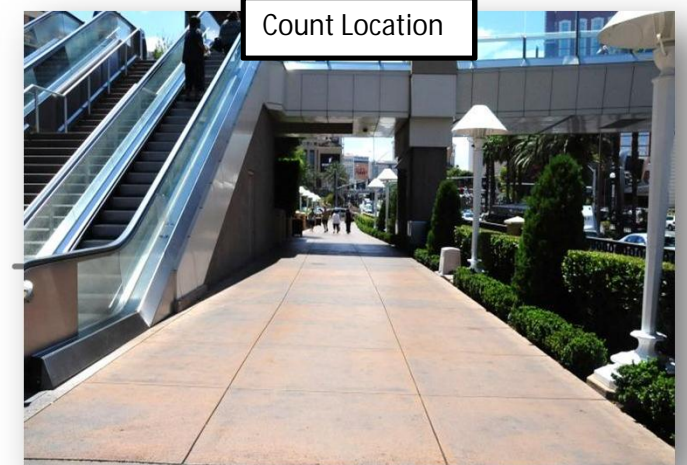

PEDESTRIAN VOLUME BY TIME OF DAY

FIGURE 3.7

North of Fashion Show Drive (Location ID: M8)
 Manual Count Location: 250 ft. North of Fashion Show Drive
 Walkway Width (W) = 6.2 feet
 Effective Walkway Width (W_E) = 3.2 feet

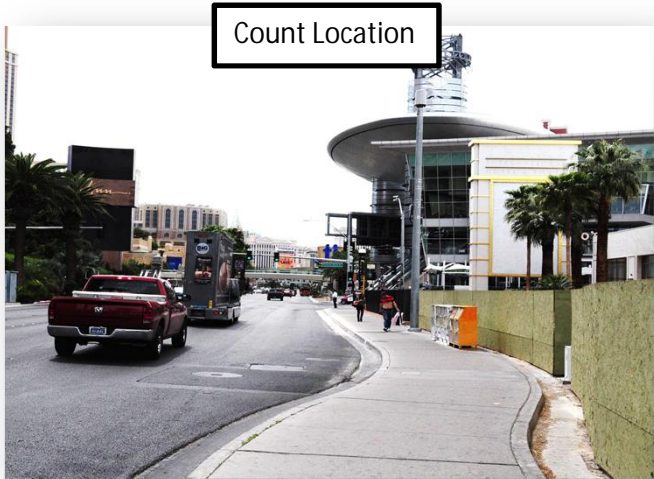

Count Location

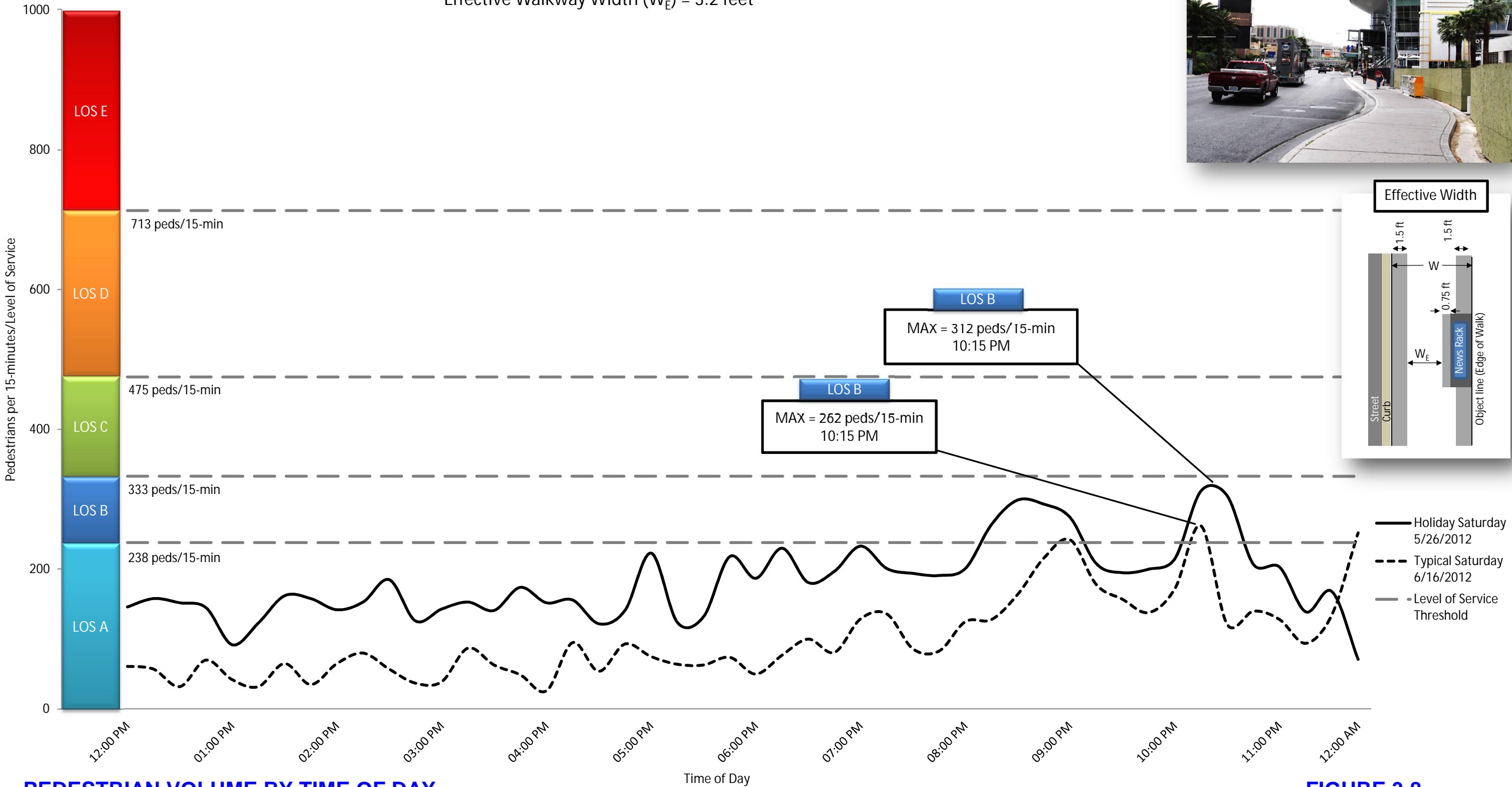

PEDESTRIAN VOLUME BY TIME OF DAY

Riviera Hotel/Casino (Location ID: 20)
 Video Count Location: 1,700 ft. North of Desert Inn Road
 Walkway Width (W) = 19 feet
 Effective Walkway Width (W_E) = 13.8 feet

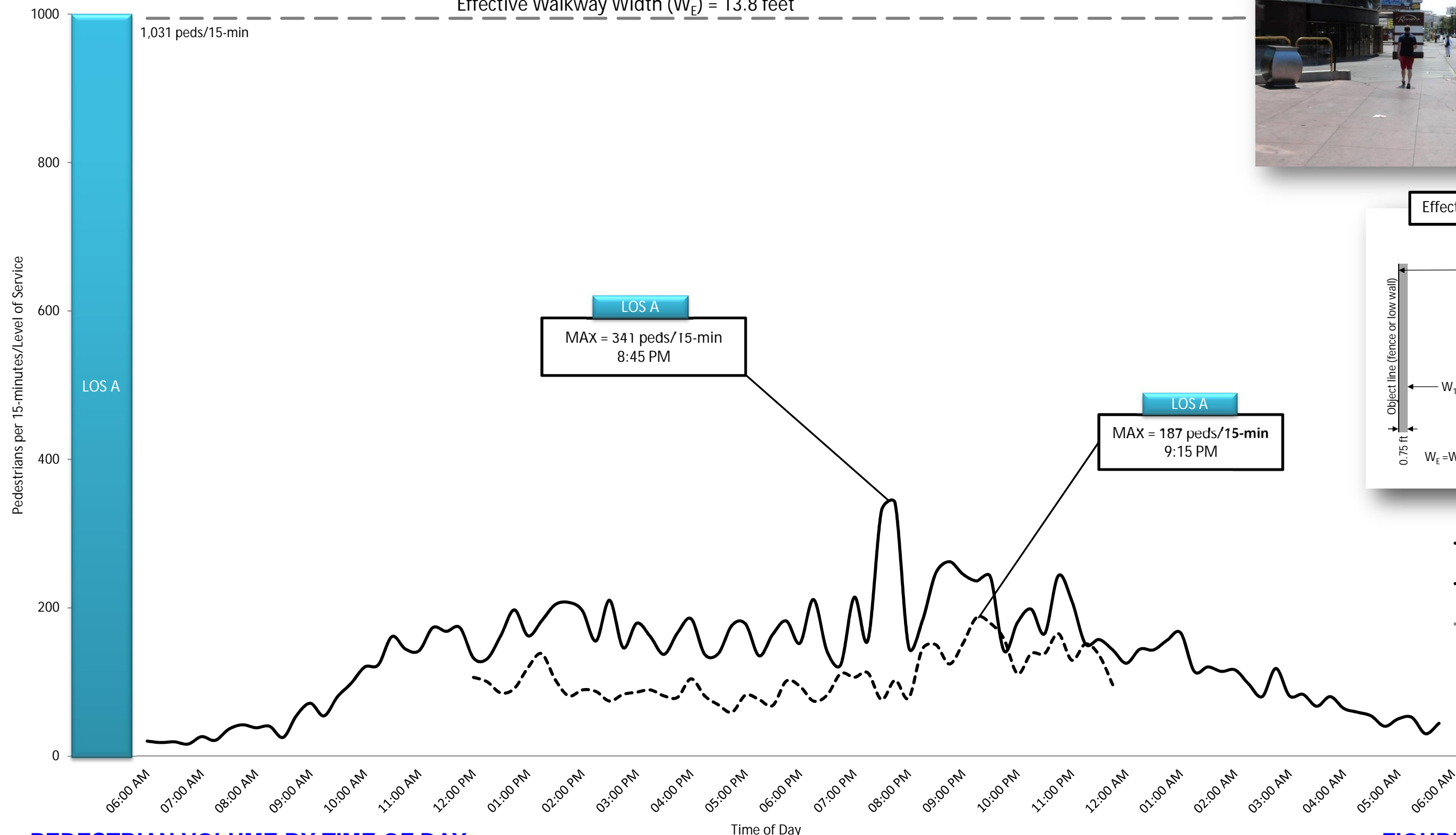
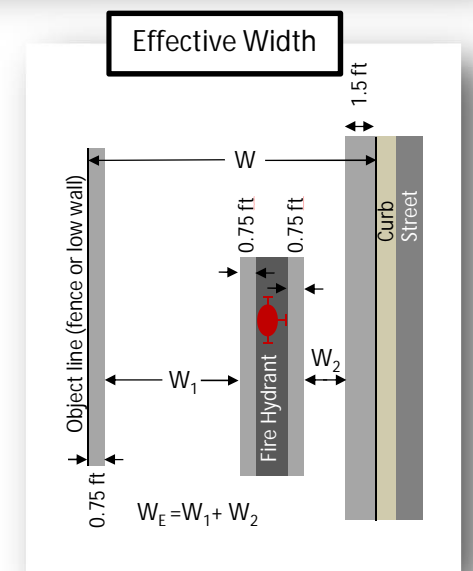

PEDESTRIAN VOLUME BY TIME OF DAY

FIGURE 3.9

Circus Circus Hotel/Casino (Location ID: 21)
 Video Count Location: 2,100 ft. North of Desert Inn Road
 Walkway Width (W) = 11.7 feet
 Effective Walkway Width (W_E) = 8.7 feet

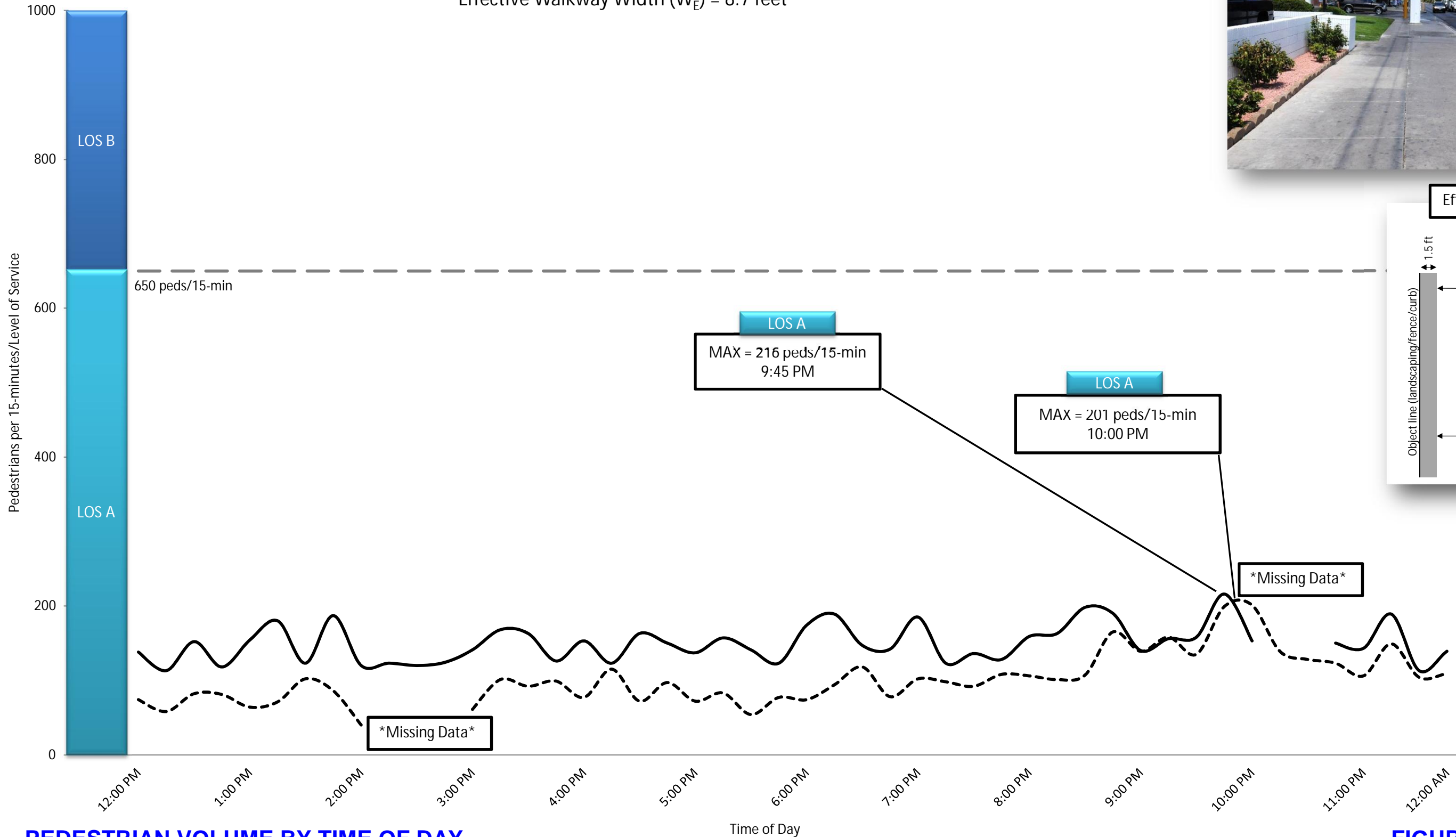
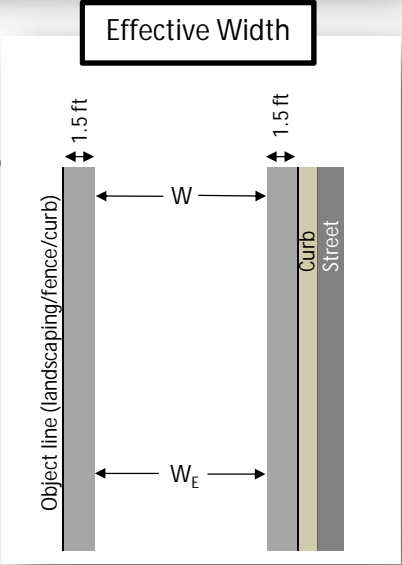
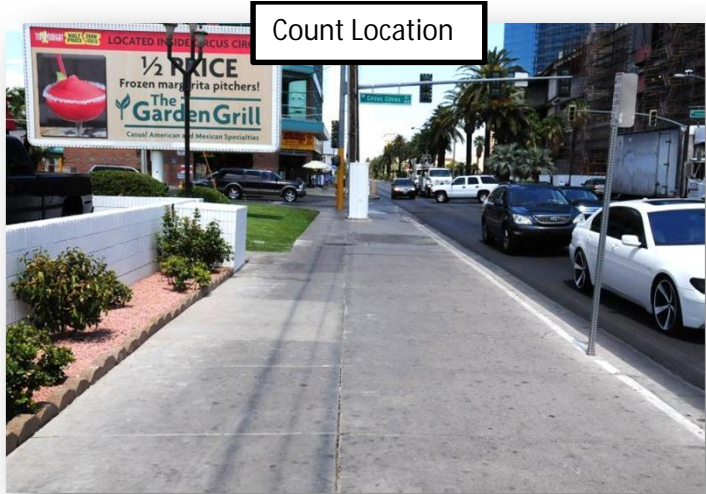

PEDESTRIAN VOLUME BY TIME OF DAY

FIGURE 3.10 42
 Kimley-Horn and Associates, Inc.

Fontainebleau Hotel/Casino (Location ID: M9)
 Manual Count Location: 1,330 ft. South of Sahara Avenue
 Walkway Width (W) = 7.5 feet
 Effective Walkway Width (W_E) = 5.3 feet

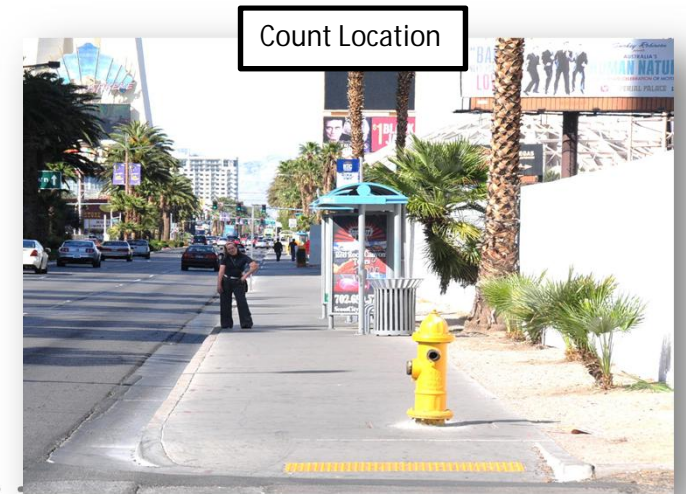

Count Location

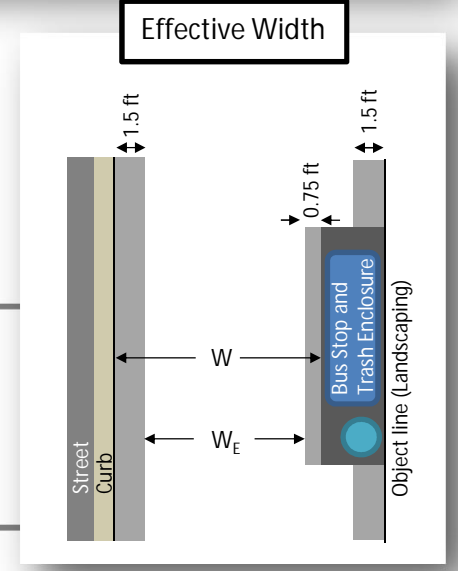
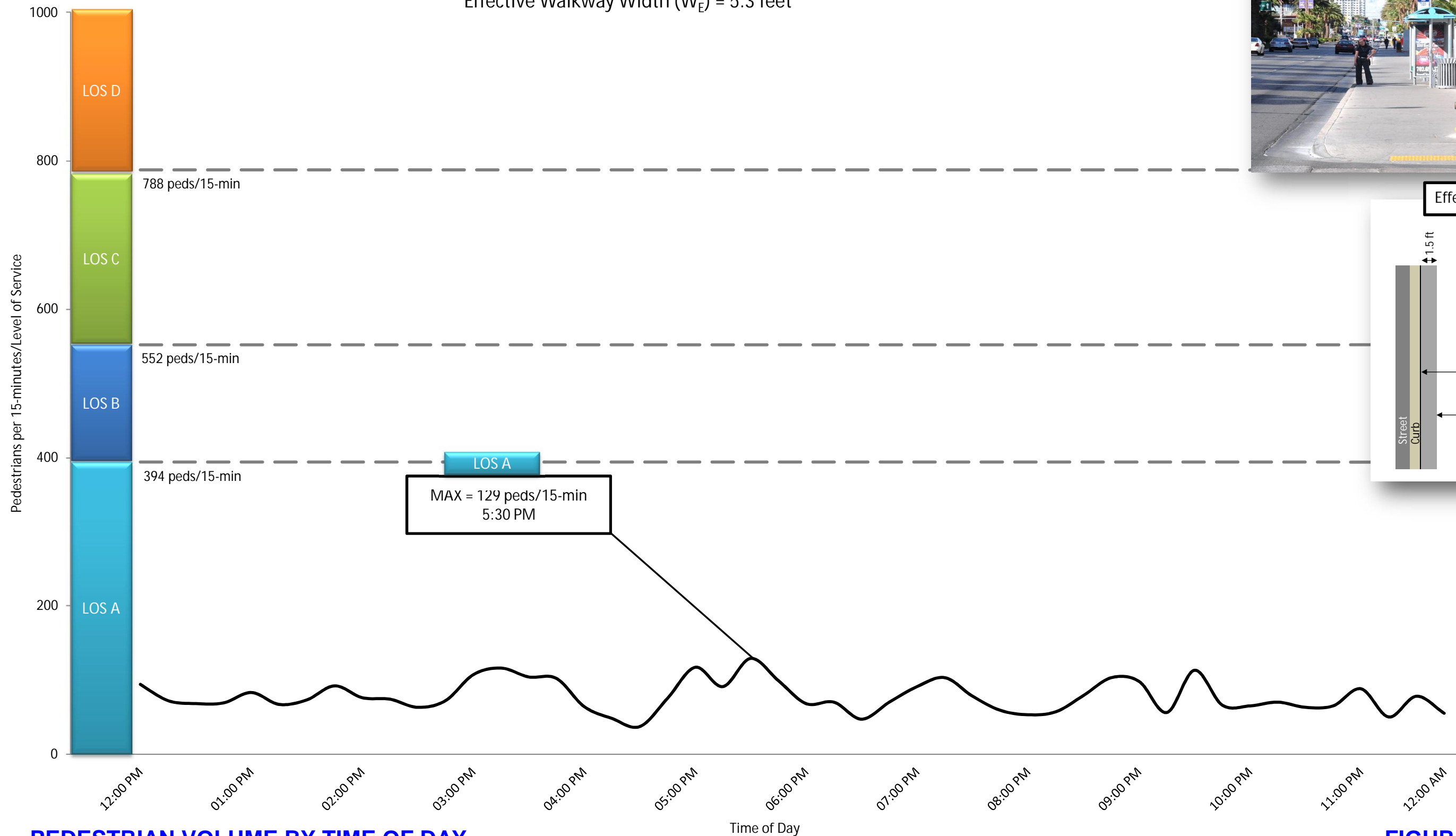

- Holiday Saturday 5/26/2012
- - - Typical Saturday 6/16/2012 No Counts
- Level of Service Threshold

PEDESTRIAN VOLUME BY TIME OF DAY

Hilton Grand Vacations (Location ID: M10)
 Manual Count Location: 1,460 ft. South of Sahara Avenue
 Walkway Width (W) = 9.7 feet
 Effective Walkway Width (W_E) = 6.7 feet

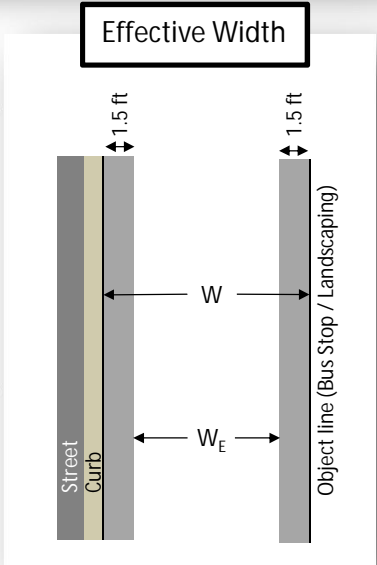
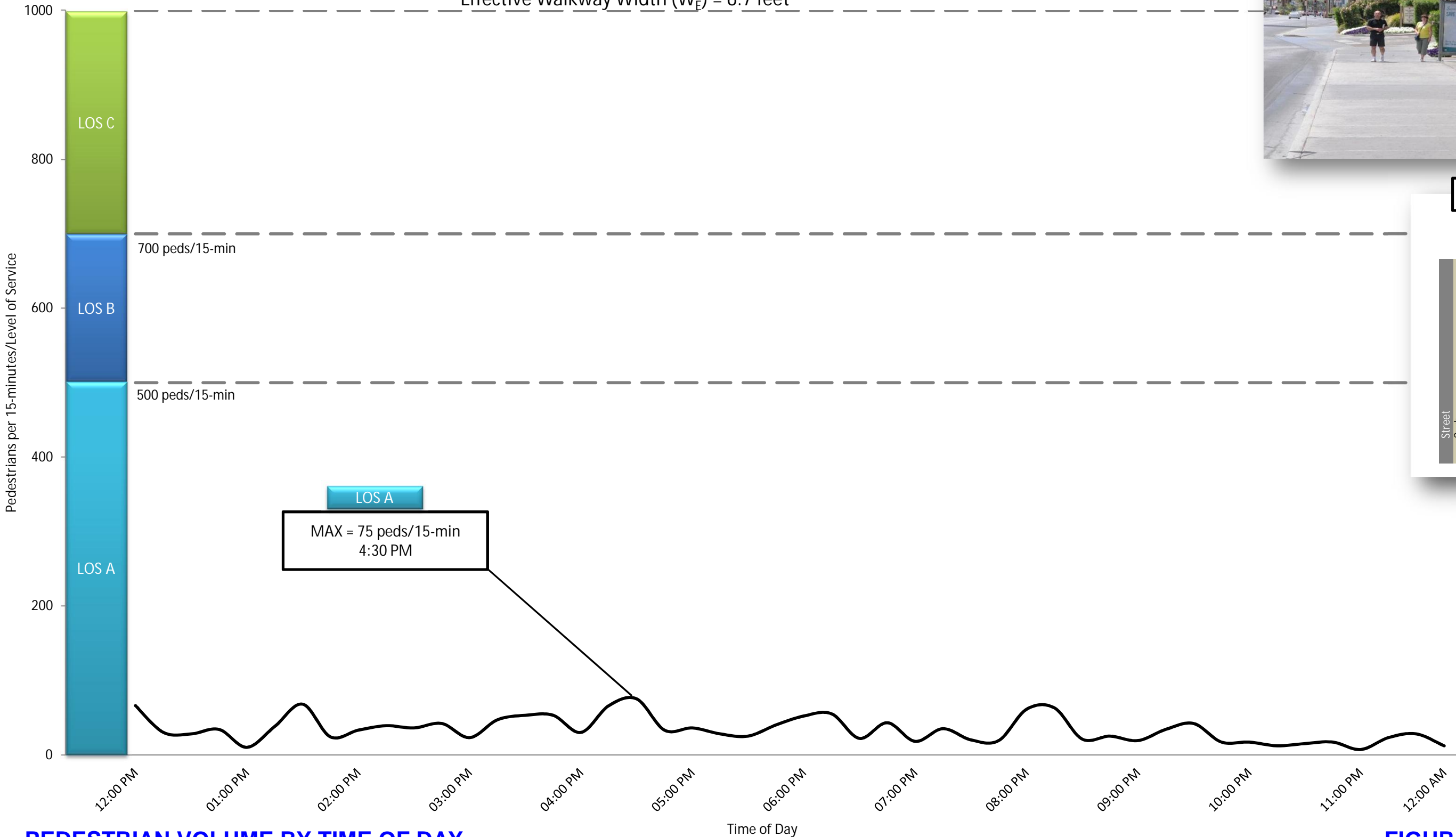

- Holiday Saturday 5/26/2012
- - - Typical Saturday 6/16/2012 No Counts
- Level of Service Threshold

PEDESTRIAN VOLUME BY TIME OF DAY

3.1.3 Inner Portion of the Study Corridor

The inner portion of the study corridor between Tropicana Avenue and Spring Mountain Road generally experienced higher pedestrian volumes than the outer portion of the study corridor.

Within the inner portion of the study corridor significant short term pedestrian volume peaking was observed near Tropicana Avenue and the MGM Grand Hotel/Casino around 9:15 PM on May 26, 2012. These peaks were attributed to the UFC event that was held at the MGM Grand Garden Arena during the data collection period. The event concluded around 9:00 PM and resulted in recognizable pedestrian peaks on the Tropicana Avenue south pedestrian bridge (see Figure 3.28) as well as other surrounding walkways and pedestrian bridges.

There are three recurring outdoor attractions within the inner portion of the study corridor on the "Strip". They are located on the west side of Las Vegas Boulevard and are free to the public. These attractions draw the attention of passers-by and are also destinations for pedestrians intending on watching the free shows. The attractions are listed below as well as their duration and show schedule during the data collection period.

- The Bellagio Fountain - Picture 3.4
 - Approximate 5 minute duration
 - Every 30 minutes from 12:00 PM to 7:00 PM
 - Every 15 minutes from 7:00 PM to 12:00 AM



Picture 3.4 – Bellagio Fountains – Daily Attraction.

- The Mirage Volcano - Picture 3.5
 - approximate 5 minute duration
 - Hourly from 8:00 PM to 12:00 AM



Picture 3.5 – Mirage Volcano – Daily Attraction.

- The Sirens of Treasure Island - Picture 3.6
 - Approximate 18 minute duration
 - Every 90 minutes from 7:00 PM to 11:30 PM

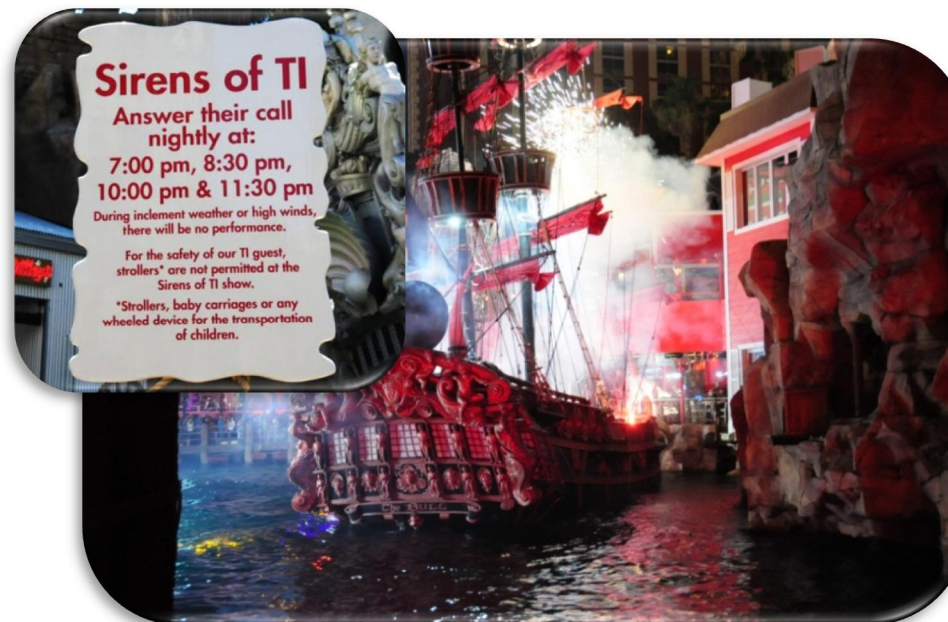

Picture 3.6 – Sirens of Treasure Island – Daily Attraction.

The Mirage Volcano and the Sirens of Treasure Island attractions were observed to impact pedestrian traffic. Pedestrians slow their walking speed during the attractions to move through the crowds and to also catch a glimpse of the show. Walking speeds are also significantly slower immediately following the end of the show, as in many cases there is a significant crowd of pedestrians exiting the show area. Figure 3.25 (Saturday May 26, 2012 - Memorial Day weekend) shows the impact to pedestrian volumes in front of the Mirage due to the volcano attraction. The graph illustrates three peaks in pedestrian volume. The 8:00 PM and 9:00 PM shows combined into a single peak with walkway volumes dropping off after the 9:00 PM show. Two additional peaks were observed after the, 10:00 PM and 11:00 PM Mirage Volcano shows. The LOS E threshold is exceeded after the 8:00 PM show at the Mirage Hotel/Casino which corresponds with the maximum 15-minute peak pedestrian volume of 1,963 pedestrians for Saturday, May 26, 2012 of Memorial Day weekend.

Pedestrian volume data was collected at the following 15 locations between Tropicana Avenue and Spring Mountain Road:

- CC1 – New York-New York Hotel/Casino - Figure 3.13
- 5 - MGM Grand Hotel/Casino - Figure 3.14
- 6 – City Center – Crystals - Figure 3.15
- Metro1 – Harley Davidson Café - Figure 3.16
- CC2 - Bellagio Hotel/Casino South - Figure 3.17
- M5 - Paris Hotel/Casino - Figure 3.18
- 9 – Bally’s Hotel/Casino - Figure 3.19
- 11A – Bellagio Hotel/Casino - Figure 3.20
- 12 - Flamingo Hotel/Casino - Figure 3.21
- M6 – Caesars Palace Hotel/Casino - Figure 3.22
- 13 – Forum Shops - Figure 3.23
- 14 – Harrah’s Hotel/Casino - Figure 3.24
- 15 – Mirage Hotel/Casino - Figure 3.25
- CC3 – Venetian Hotel/Casino - Figure 3.26
- CC4 – Treasure Island Hotel/Casino - Figure 3.27

Pedestrian volumes were found to exceed LOS C at the following locations:

- Metro1 – Harley Davidson Cafe
- 12 - Flamingo Hotel/Casino
- M6 – Caesars Palace Hotel/Casino
- 13 – Forum Shops
- 14 – Harrah’s Hotel/Casino
- 15 – Mirage Hotel/Casino
- CC3 – Venetian Hotel/Casino

The time periods when LOS C was found to be exceeded are identified by a red rectangle on the volume graph with the time periods identified.

Table 3.2 shows the summary of data collected within the inner portion of the study corridor. Note that private video data was not provided for every location on both the holiday and typical Saturday. Picture 3.7 through Picture 3.9 show typical walkway activity for the inner portion of the study corridor.

Table 3.2 - Data Summary for Inner Portion of the Study Corridor

Holiday Saturday - May 26, 2012											
West Side						East Side					
ID	Name	W _E	Max 15-min Volume	Time of Max Volume	LOS	ID	Name	W _E	Max 15-min Volume	Time of Max Volume	LOS
CC1	New York-New York	8.3	1043	11:00PM - 11:15PM	C	5	MGM Grand	18.4	1343	9:30PM - 9:45PM	A
CC2	Bellagio South	21.5	2633	9:30PM - 9:45PM	C	Metro1	Harley Davidson	5.0	1140	4:00PM - 4:15PM	E
M6	Caesars Palace	6.8	1684	9:15PM - 9:30PM	D	M5	Paris	10.3	2124	4:15PM - 4:30PM	C
13	Forum Shops	12.0	2092	11:30PM - 11:45PM	D	9	Bally's	28.0	1780	4:15PM - 4:30PM	A
15	Mirage	8.7	1963	8:45PM - 9:00PM	E	12	Flamingo	8.5	1459	9:45PM - 10:00PM	D
						14	Harrah's	6.7	1242	2:30PM - 2:45PM	D
						CC3	Venetian	6.3	1323	8:45PM - 9:00PM	D

Typical Saturday - June 16, 2012											
West Side						East Side					
ID	Name	W _E	Max 15-min Volume	Time of Max Volume	LOS	ID	Name	W _E	Max 15-min Volume	Time of Max Volume	LOS
CC1	New York-New York	8.3	358	11:30PM - 11:45PM	C	5	MGM Grand	18.4	739	10:00PM - 10:15PM	A
6	Crystals	17.7	619	10:00PM - 10:15PM	A	Metro1	Harley Davidson	5.0	1290	10:00PM - 10:15PM	E
CC2	Bellagio South	21.5	1595	10:00PM - 10:15PM	A	M5	Paris	10.3	1417	10:00PM - 10:15PM	B
11A	Bellagio	15.0	1573	10:30PM - 10:45PM	B	9	Bally's	28.0	880	12:30PM - 12:45PM	A
M6	Caesars Palace	6.8	1338	9:15PM - 9:30PM	C	14	Harrah's	6.7	1152	9:00PM - 9:15PM	D
13	Forum Shops	12.0	1787	10:15PM - 10:30PM	C	CC3	Venetian	6.3	1737	11:15PM - 11:30PM	E
15	Mirage	8.7	754	8:00PM - 8:15PM	B						
CC4	Treasure Island	1.7	287	10:15PM - 10:30PM	D						



Picture 3.7 – Pedestrian Activity at New York-New York Holiday Saturday.



Picture 3.8 – Pedestrian Activity at Venetian Hotel/Casino Holiday Saturday.



Picture 3.9 – Pedestrian Activity at Bellagio Hotel/Casino South Typical Saturday.

New York New York Hotel/Casino (Location ID: CC1)
 Video Count Location: 780 ft. North of Tropicana Avenue
 Walkway Width (W) = 10.5 feet
 Effective Walkway Width (W_E) = 8.3 feet



Count Location

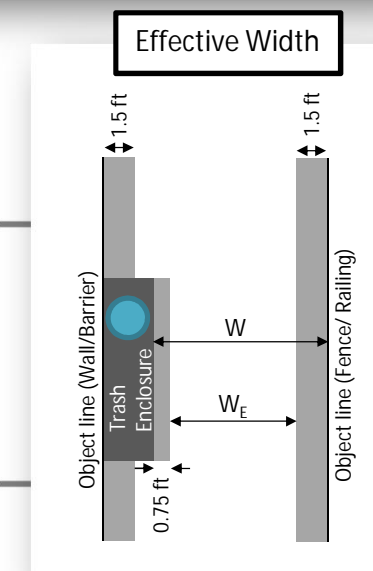
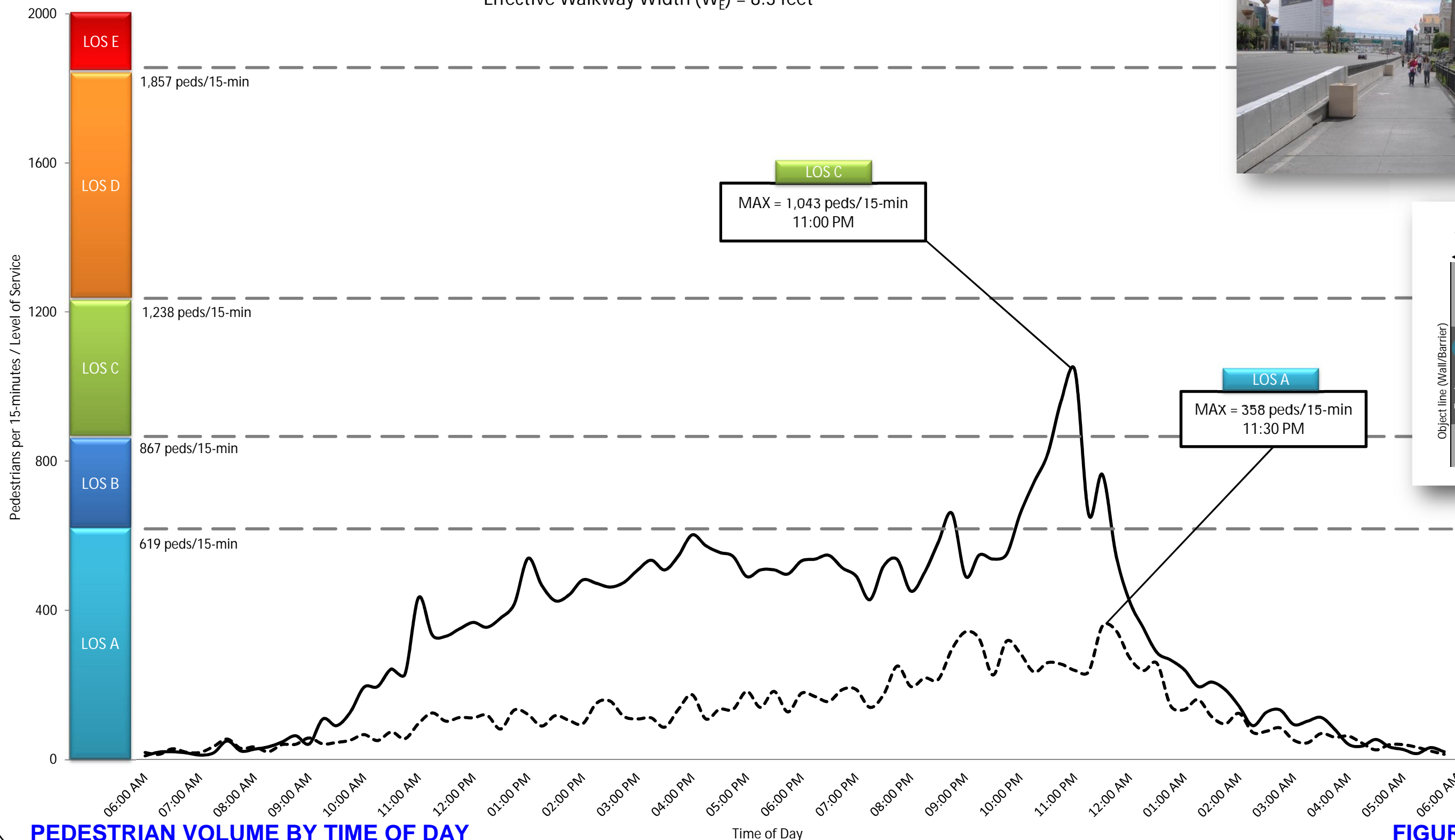

PEDESTRIAN VOLUME BY TIME OF DAY

MGM Grand Hotel/Casino (Location ID: 5)
 Video Count Location: 310 ft. North of Tropicana Avenue
 Walkway Width (W) = 20.7 feet
 Effective Walkway Width (W_E) = 18.4 feet

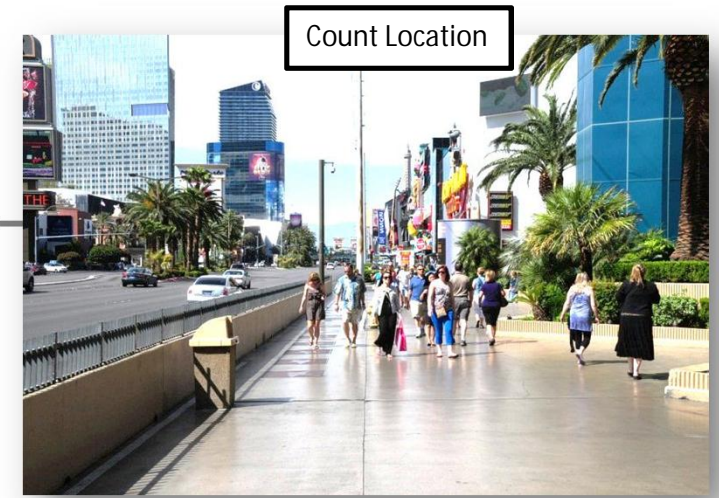

Count Location

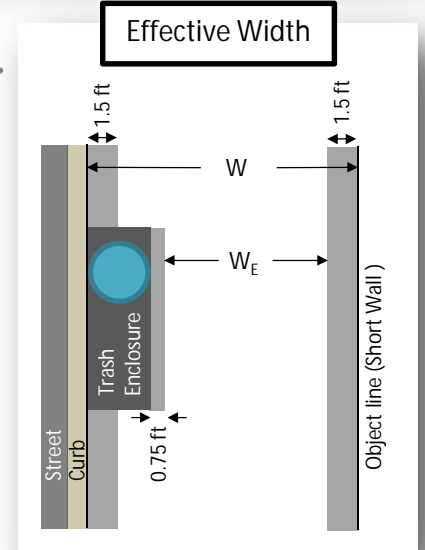
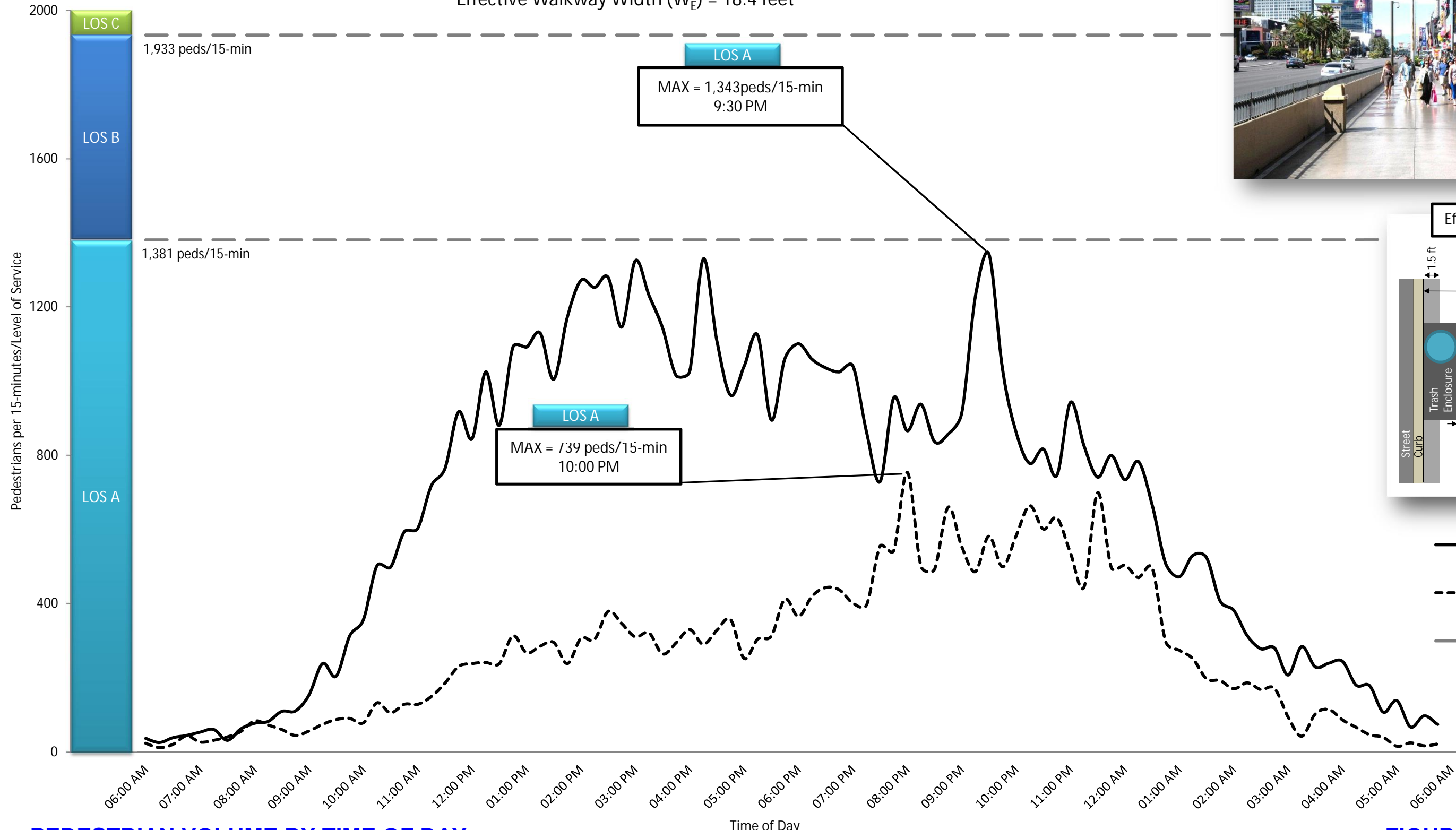

- Holiday Saturday 5/26/2012
- - - Typical Saturday 6/16/2012
- Level of Service Threshold

PEDESTRIAN VOLUME BY TIME OF DAY

City Center - Crystals (Location ID: 6)
 Video Count Location: 460 ft. South of Harmon Avenue
 Walkway Width (W) = 20.7 feet
 Effective Walkway Width (W_E) = 17.7 feet

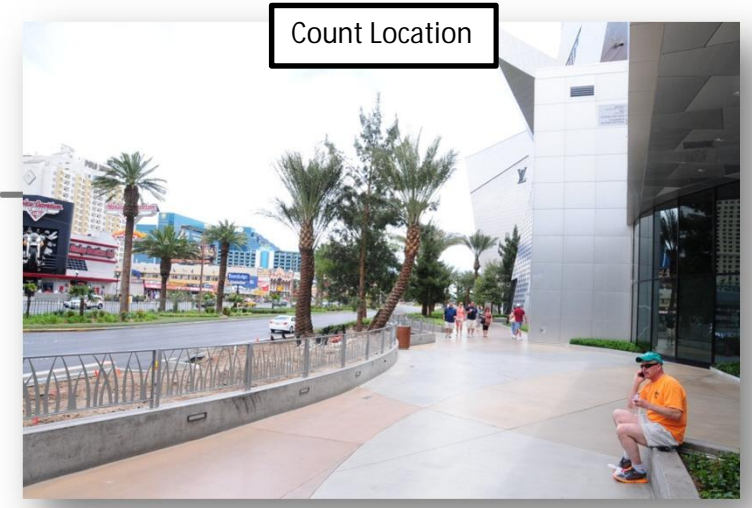

Count Location

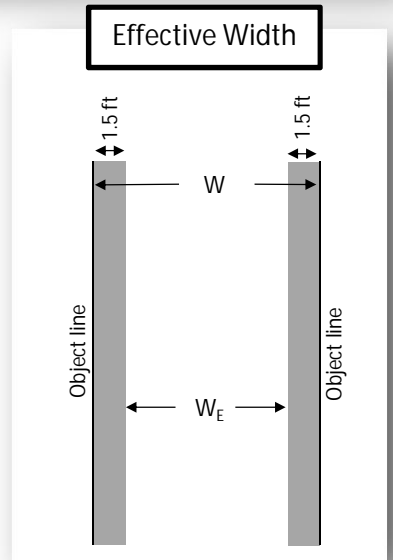
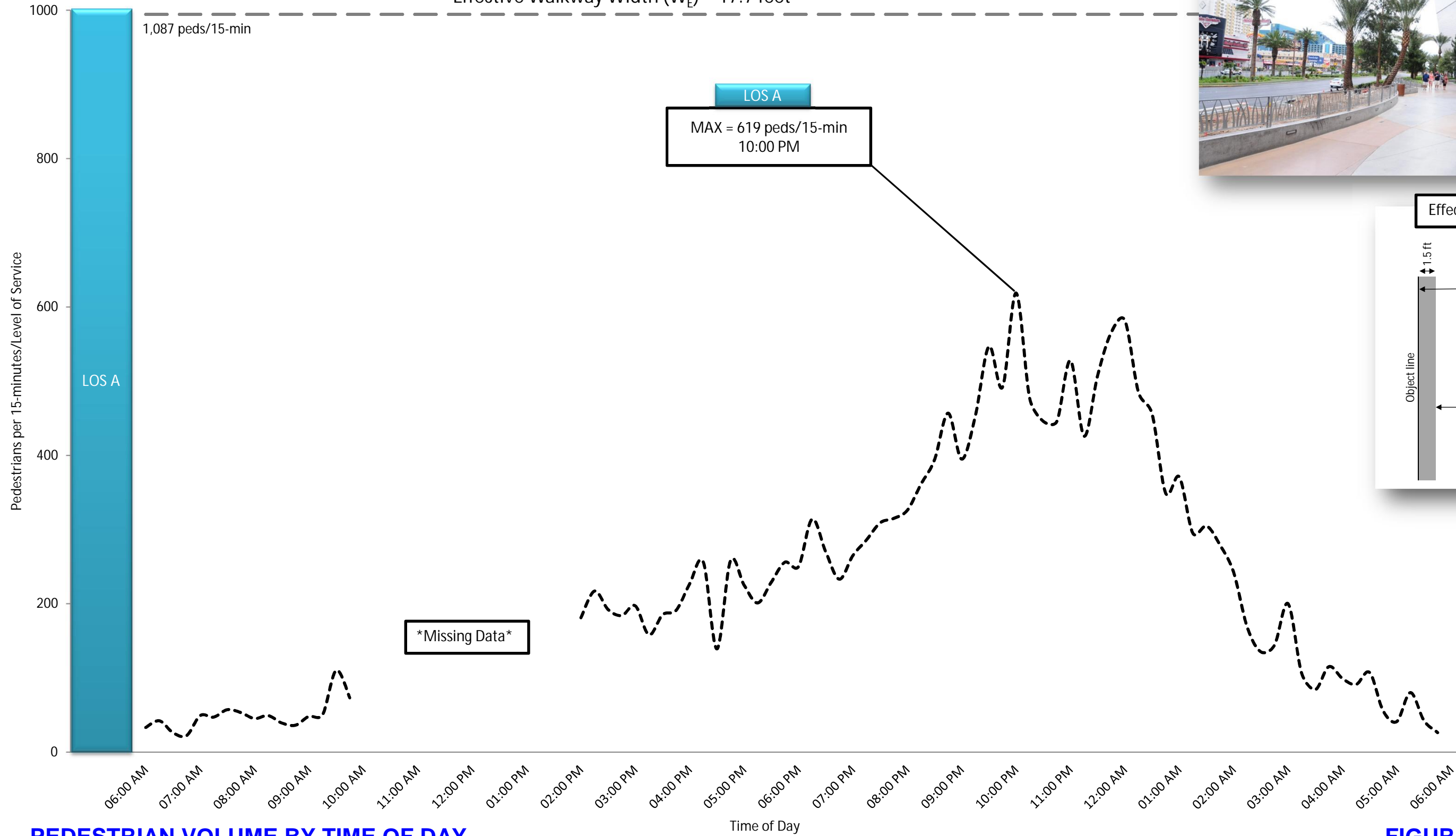

- Holiday Saturday 5/26/2012 Not Collected
- - - Typical Saturday 6/16/2012
- Level of Service Threshold

PEDESTRIAN VOLUME BY TIME OF DAY

Harley Davidson Cafe (Location ID: Metro1)
 Video Count Location: 270 ft. South of Harmon Avenue
 Walkway Width (W) = 8 feet
 Effective Walkway Width (W_E) = 5 feet

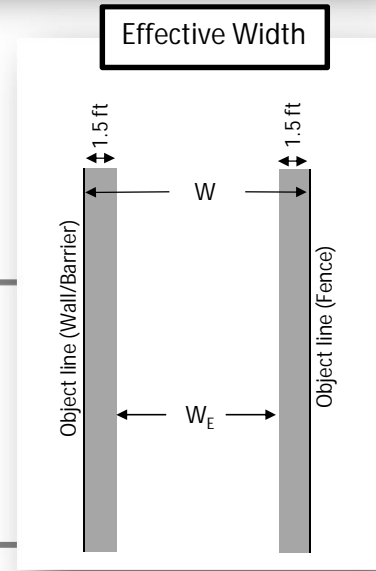
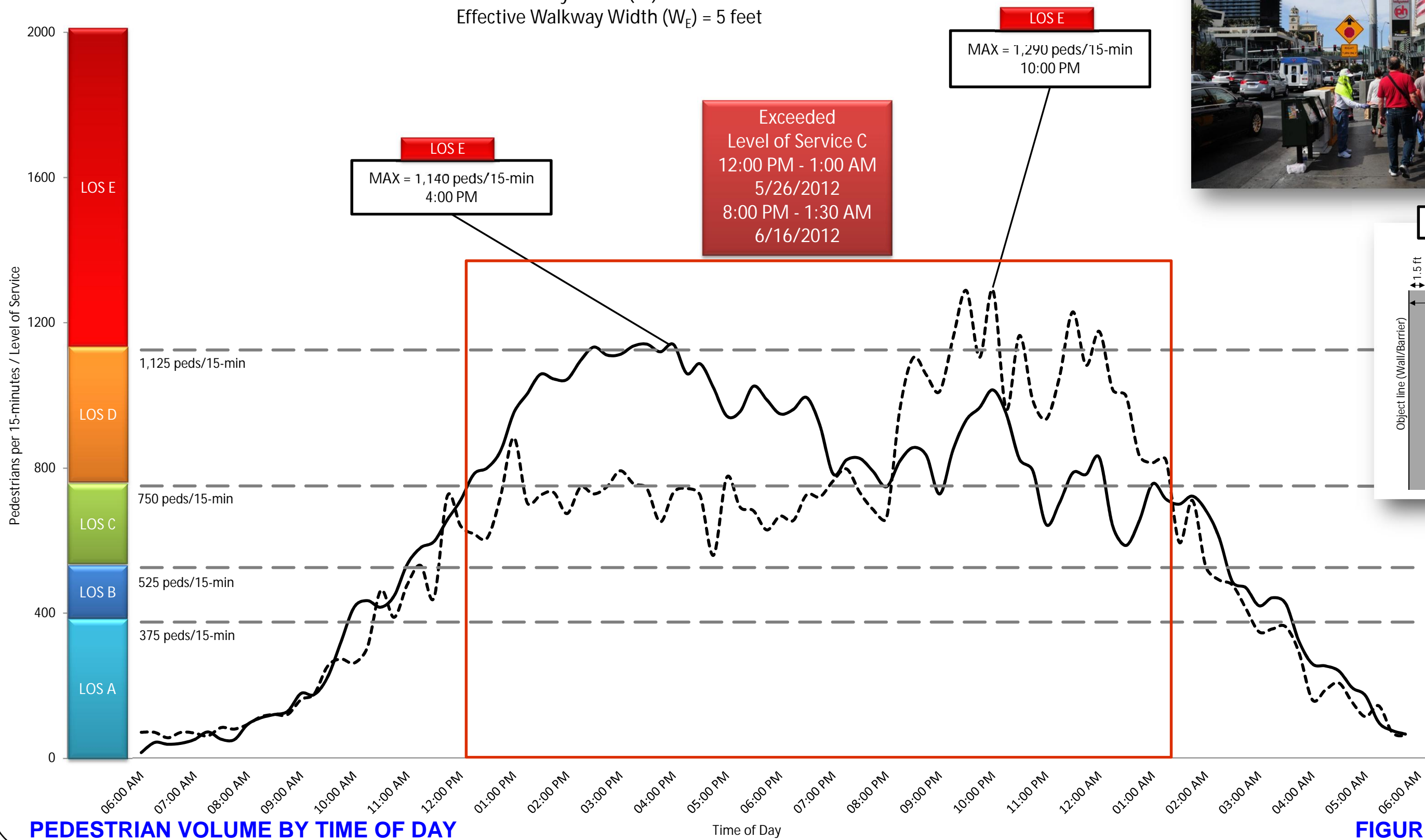
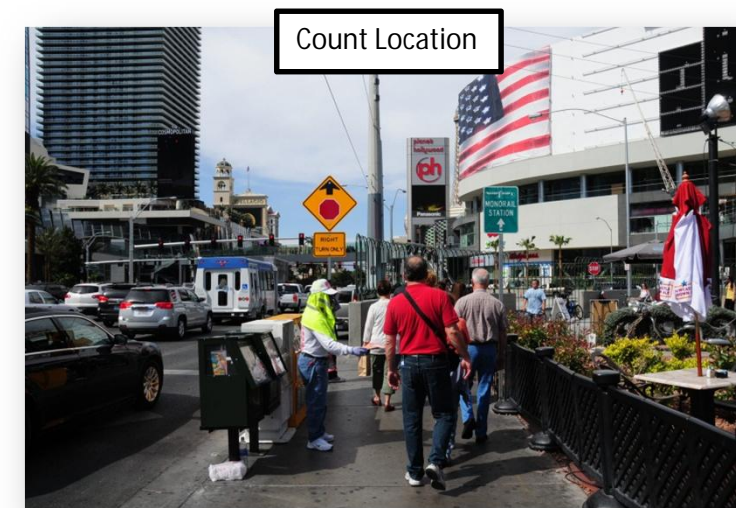

PEDESTRIAN VOLUME BY TIME OF DAY

Bellagio Hotel/Casino South (Location ID: CC2)
 Video Count Location: 580 ft. North of Harmon Avenue
 Walkway Width (W) = 27 feet
 Effective Walkway Width (W_E) = 21.5 feet

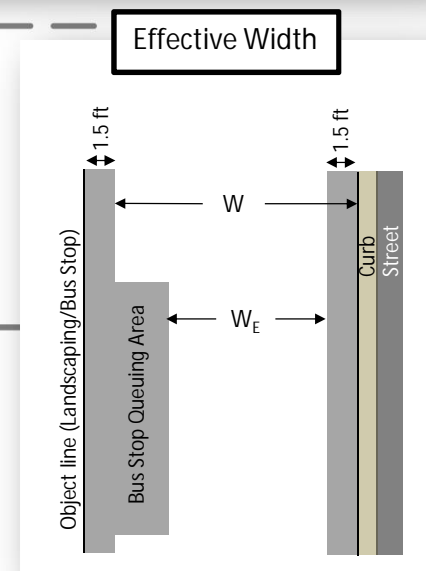
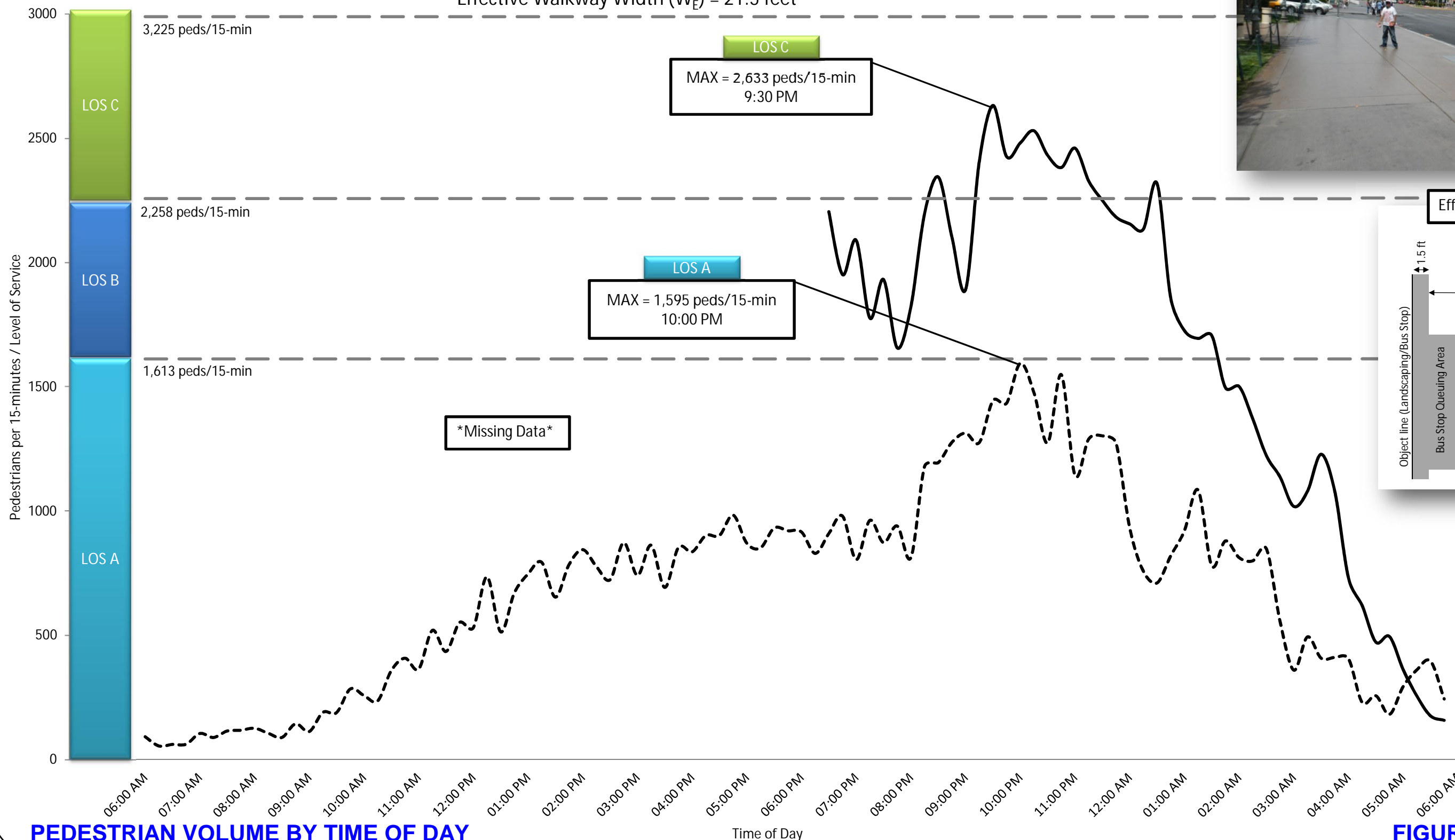

PEDESTRIAN VOLUME BY TIME OF DAY

Paris Hotel/Casino (Location ID: M5)
 Manual Count Location: 970 ft. South of Flamingo Road
 Walkway Width (W) = 16.8 feet
 Effective Walkway Width (W_E) = 10.3 feet

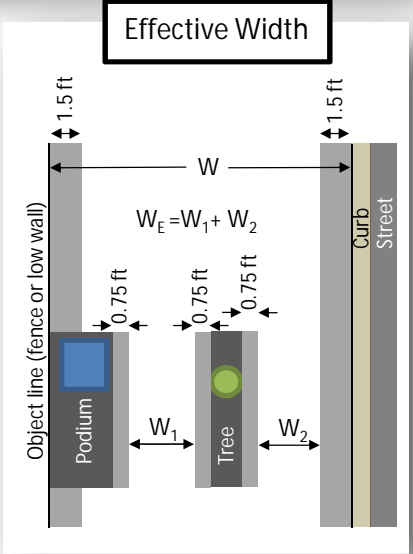
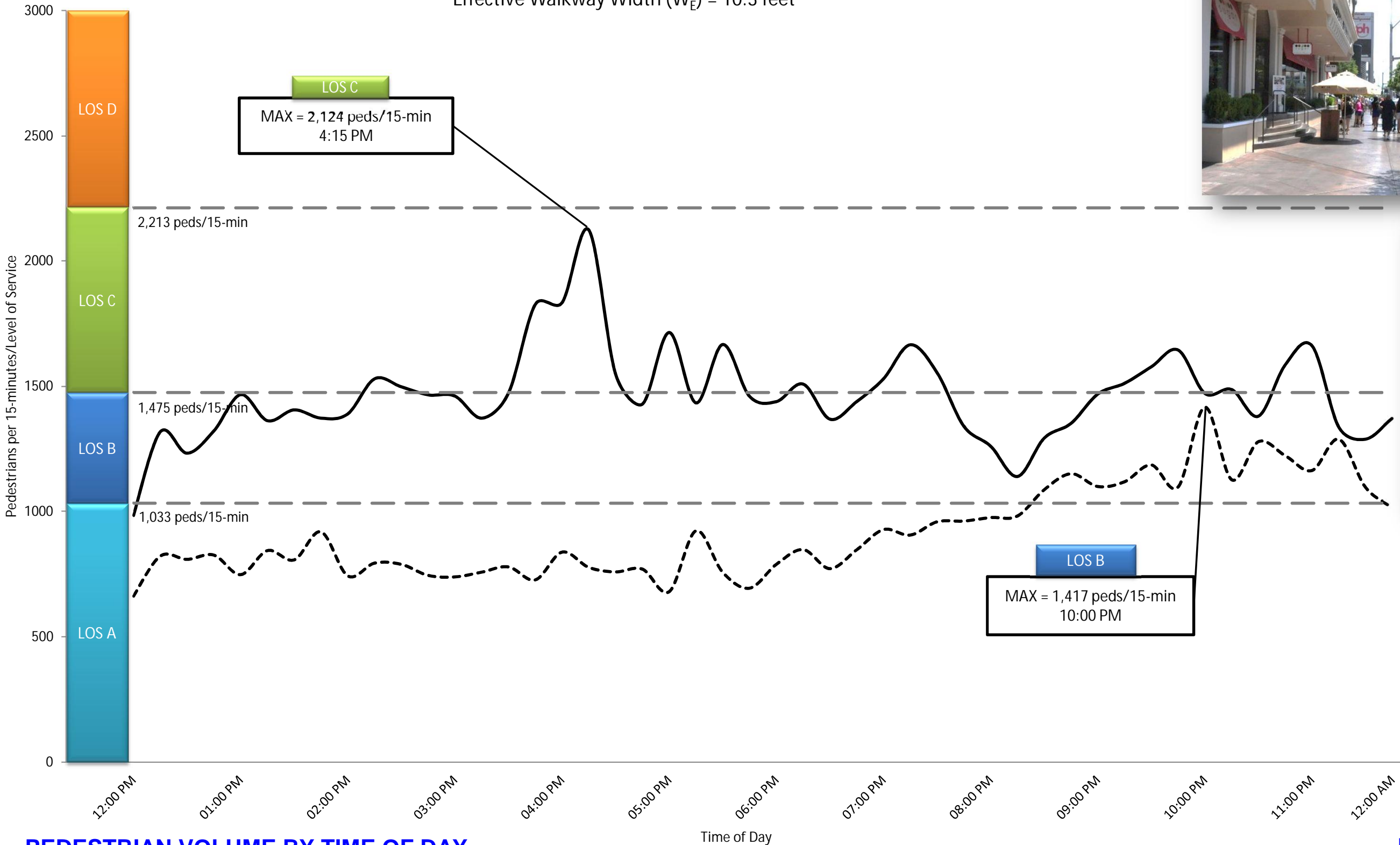
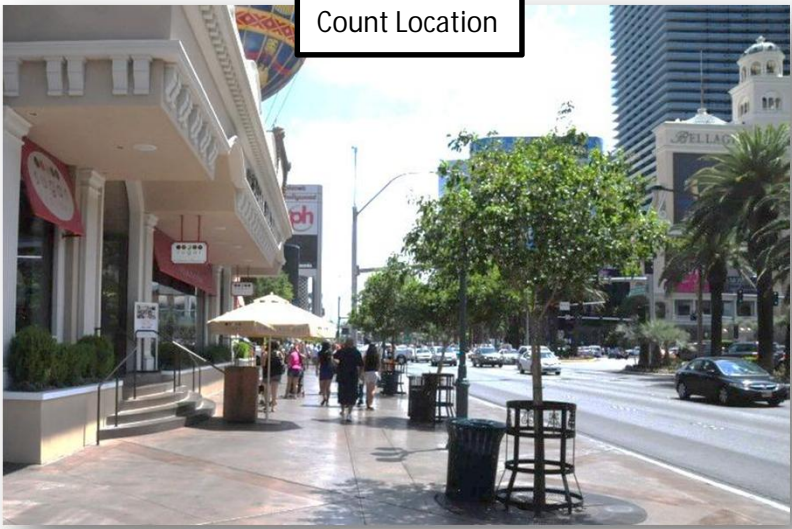

- Holiday Saturday 5/26/2012
- - - Typical Saturday 6/16/2012
- - - Level of Service Threshold

PEDESTRIAN VOLUME BY TIME OF DAY

Bally's Hotel/Casino (Location ID: 9)
 Video Count Location: 170 ft. South of Flamingo Road
 Walkway Width (W) = 43.5 feet
 Effective Walkway Width (W_E) = 28 feet

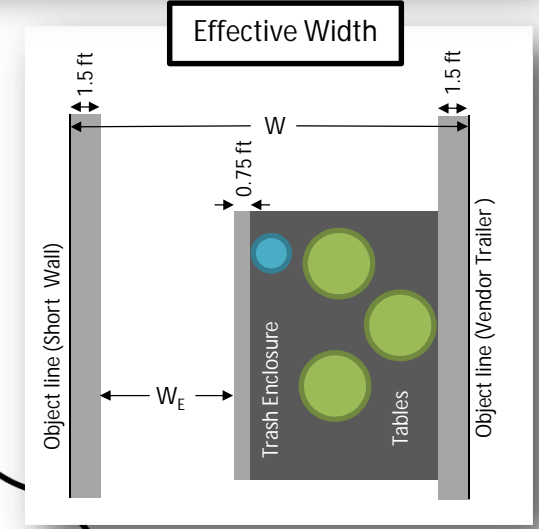
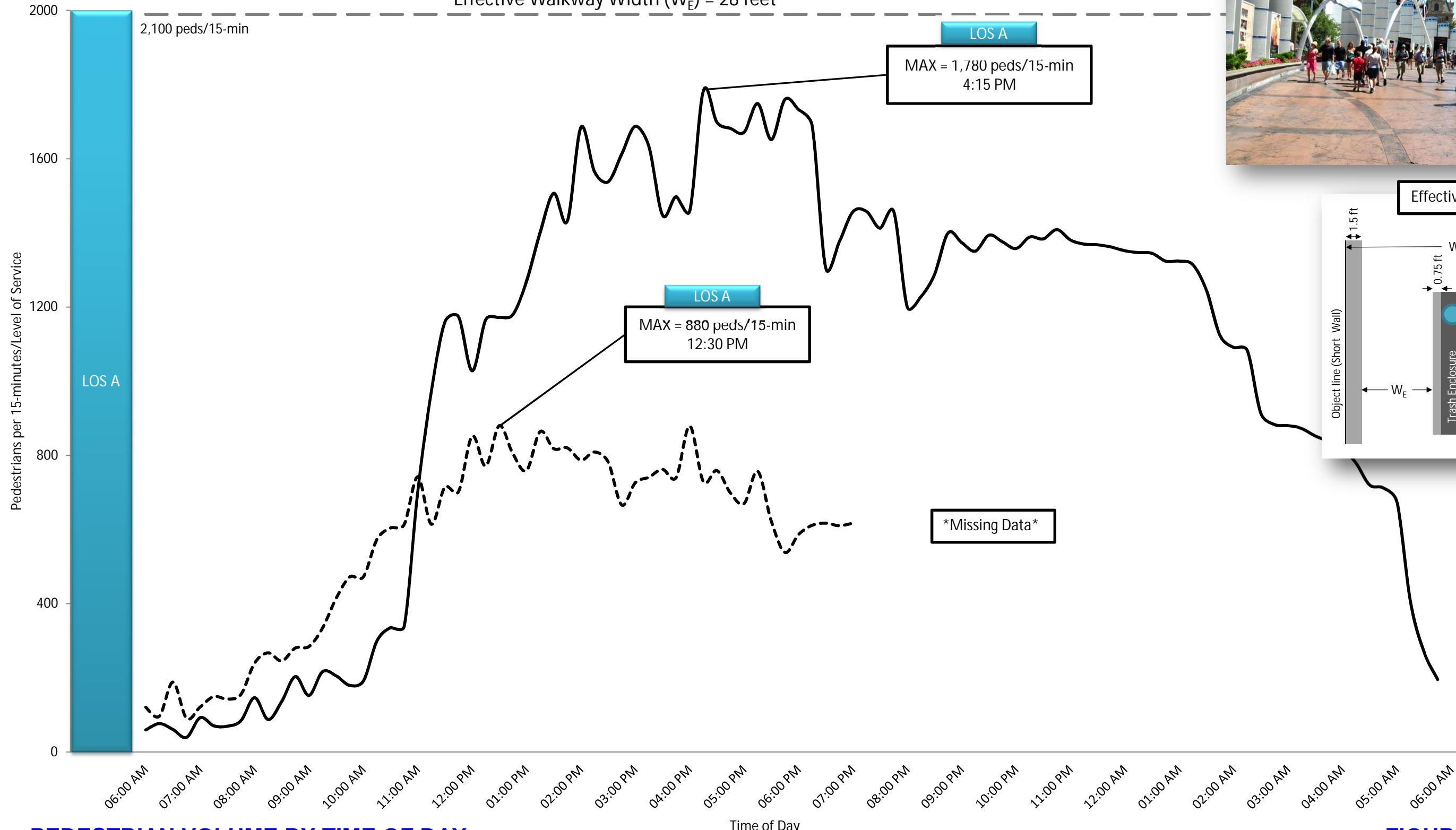
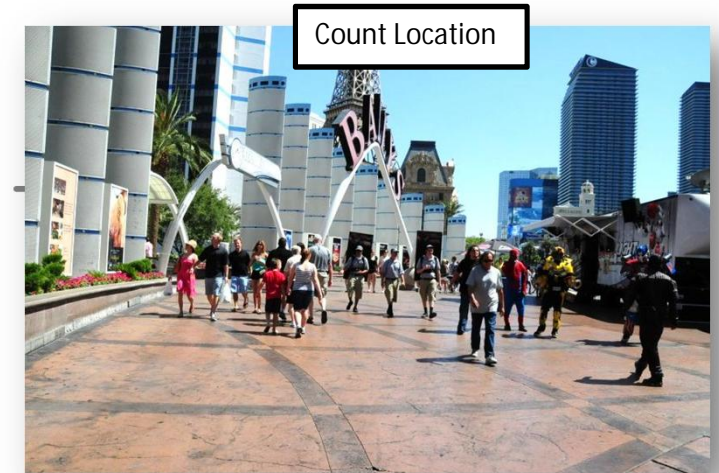

- Holiday Saturday 5/26/2012
- - - Typical Saturday 6/16/2012
- Level of Service Threshold

PEDESTRIAN VOLUME BY TIME OF DAY

Bellagio Hotel/Casino (Location ID: 11A)
 Video Count Location: 190 ft. South of Flamingo Road
 Walkway Width (W) = 18 feet
 Effective Walkway Width (W_E) = 15 feet



LOS B
 MAX = 1,543 peds/15-min
 10:30 PM

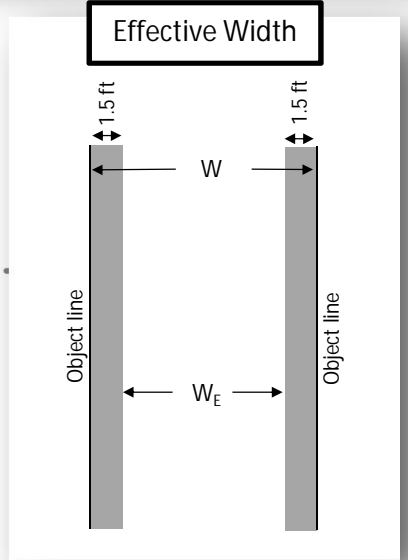
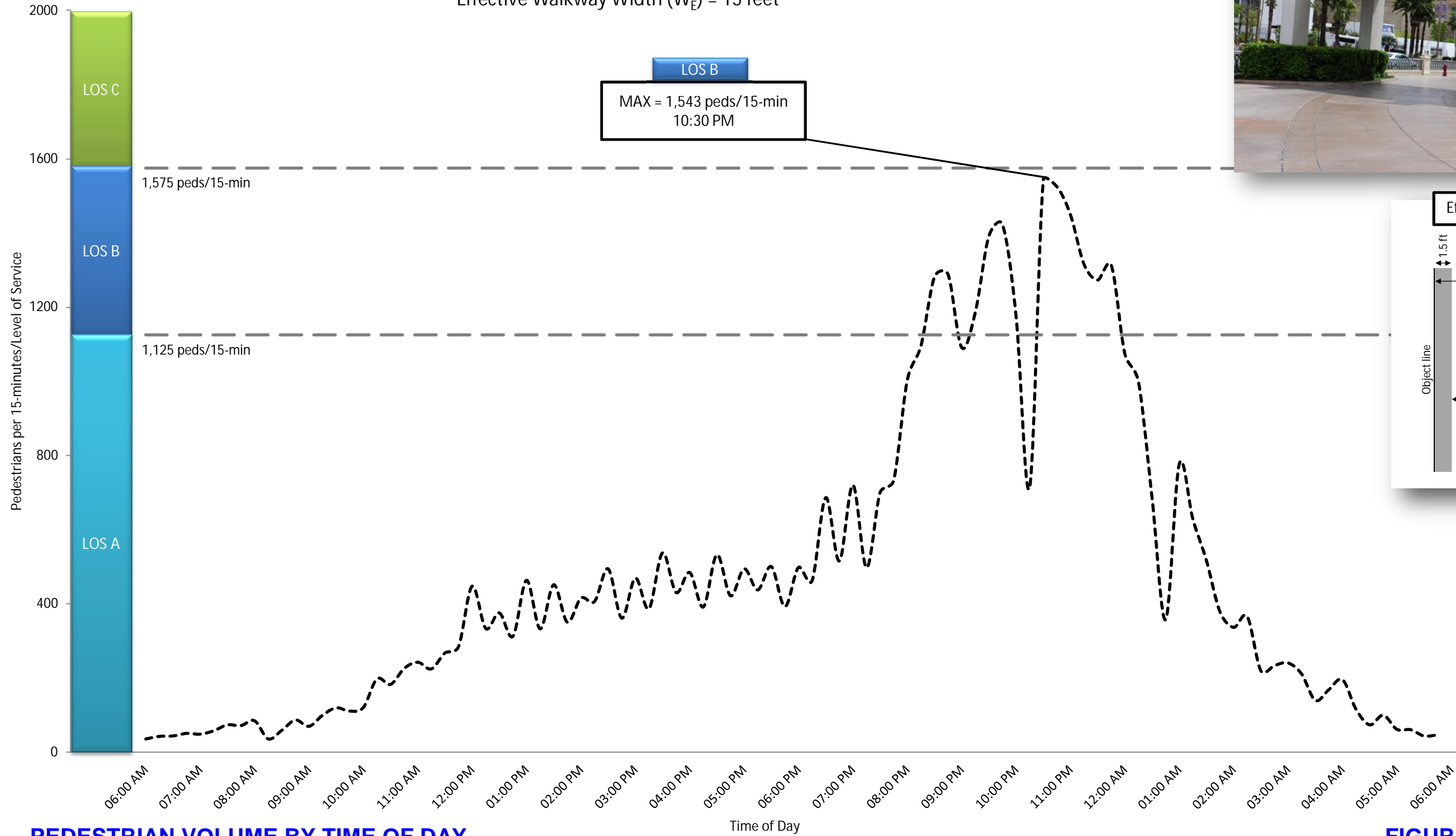

— Holiday Saturday
 5/26/2012
 Not Collected
 - - - Typical Saturday
 6/16/2012

PEDESTRIAN VOLUME BY TIME OF DAY

Flamingo Hotel/Casino (Location ID: 12)
 Video Count Location: 750 ft. North of Flamingo Road
 Walkway Width (W) = 10.8 feet
 Effective Walkway Width (W_E) = 8.5 feet

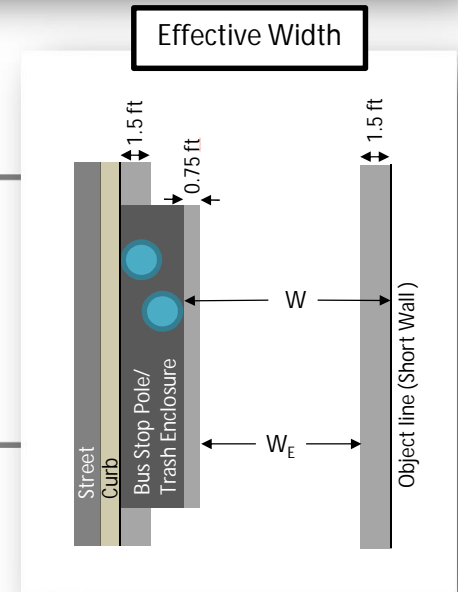
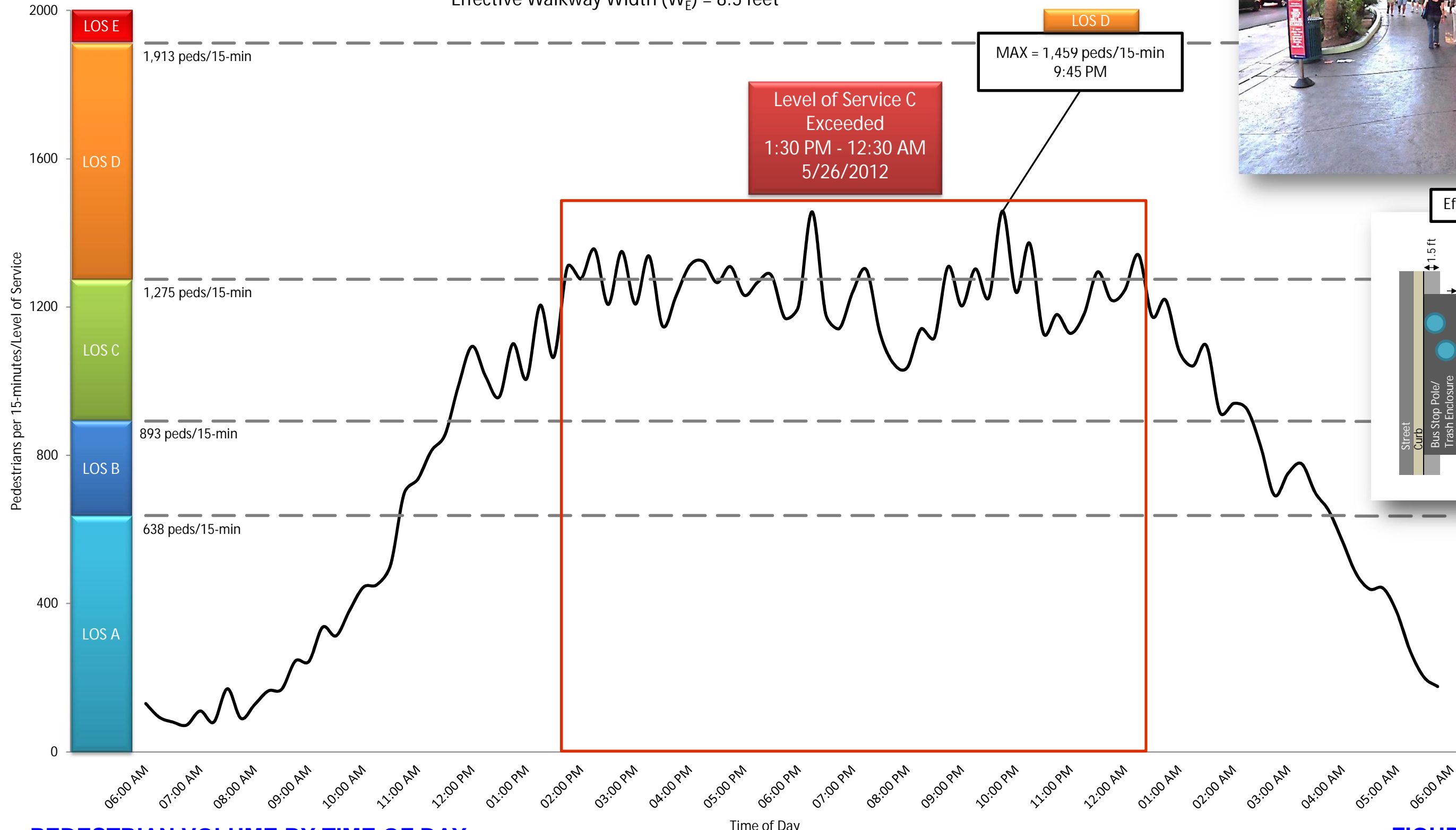

PEDESTRIAN VOLUME BY TIME OF DAY

Caesar's Palace Hotel/Casino (Location ID: M6)
 Manual Count Location: 630 ft. North of Flamingo Road
 Walkway Width (W) = 9 feet
 Effective Walkway Width (W_E) = 6.8 feet



Count Location

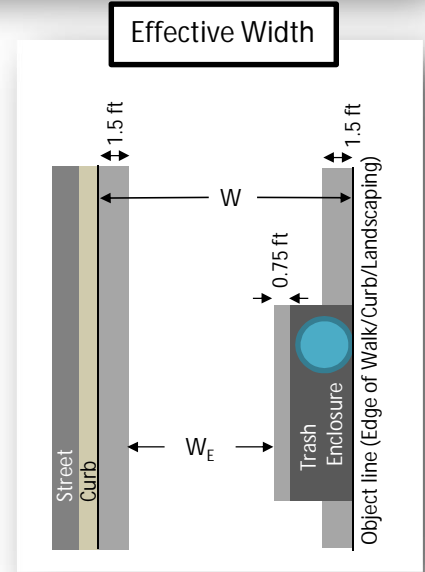
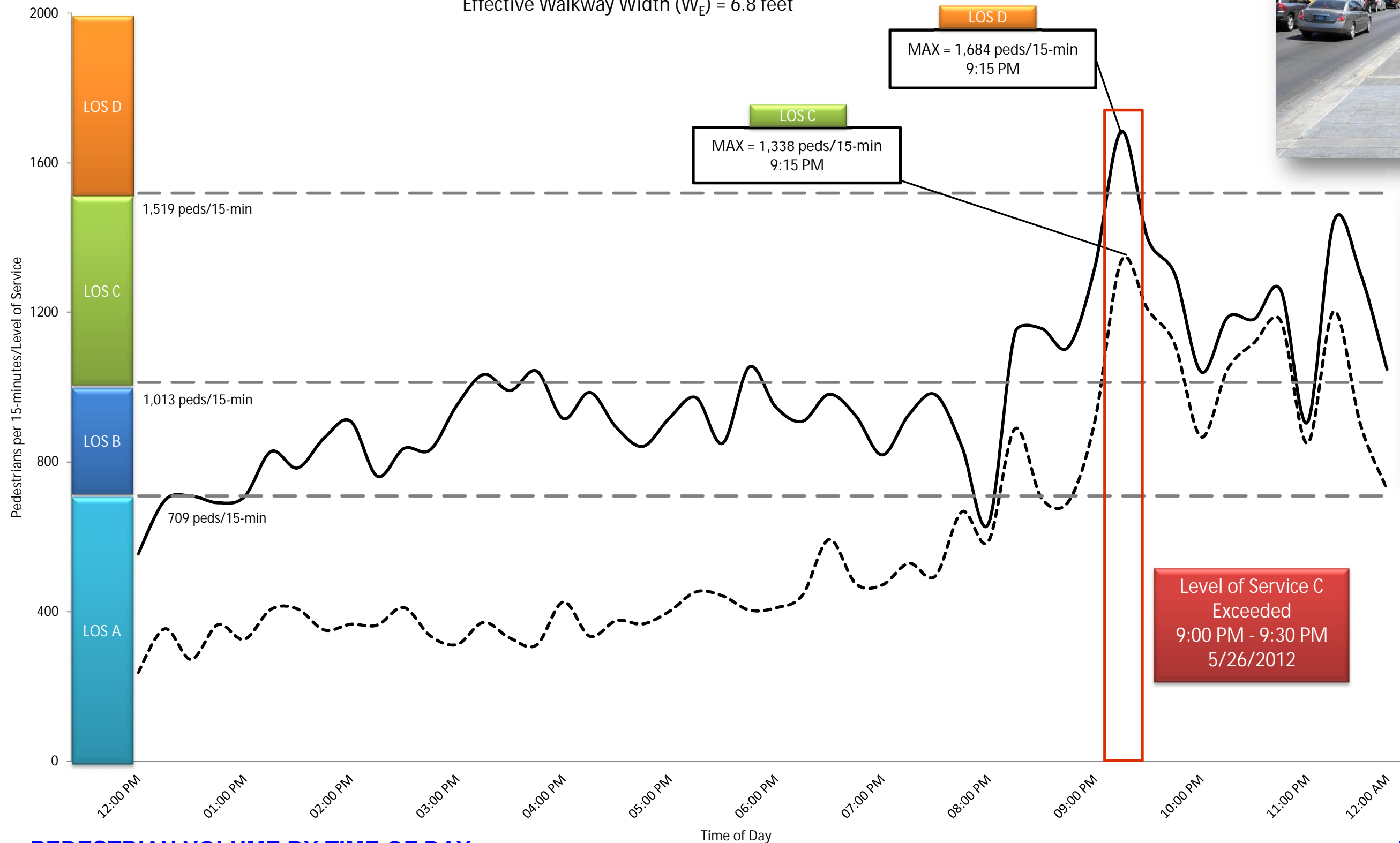

- Holiday Saturday 5/26/2012
- - - Typical Saturday 6/16/2012
- - - Level of Service Threshold

Level of Service C Exceeded
9:00 PM - 9:30 PM
5/26/2012

PEDESTRIAN VOLUME BY TIME OF DAY

Forum Shops (Location ID: 13)
 Video Count Location: 1,610 ft. North of Flamingo Road
 Walkway Width (W) = 15 feet
 Effective Walkway Width (W_E) = 12 feet

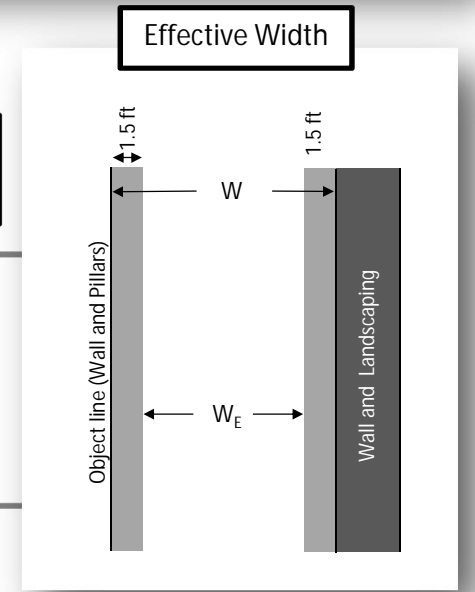
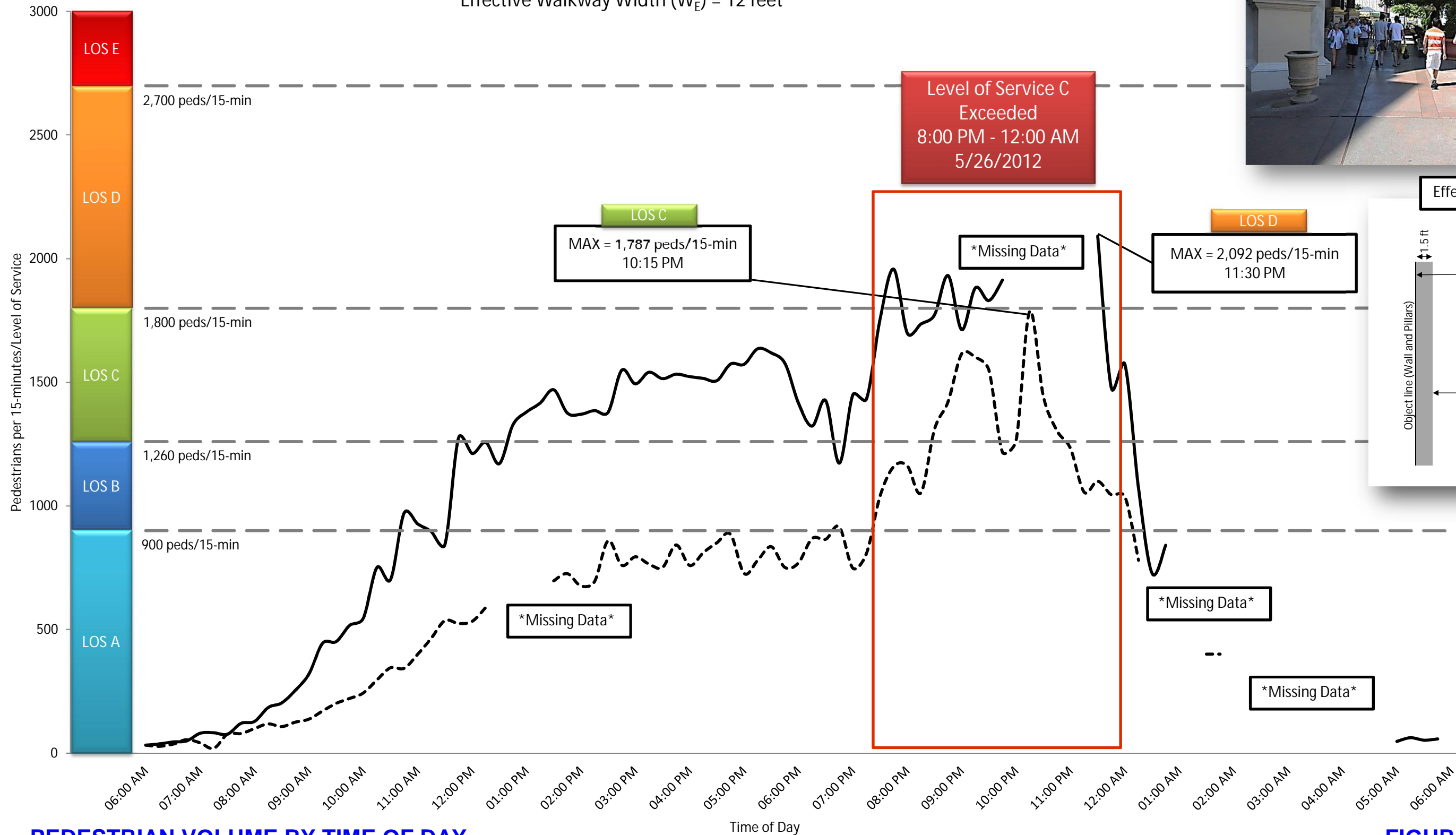
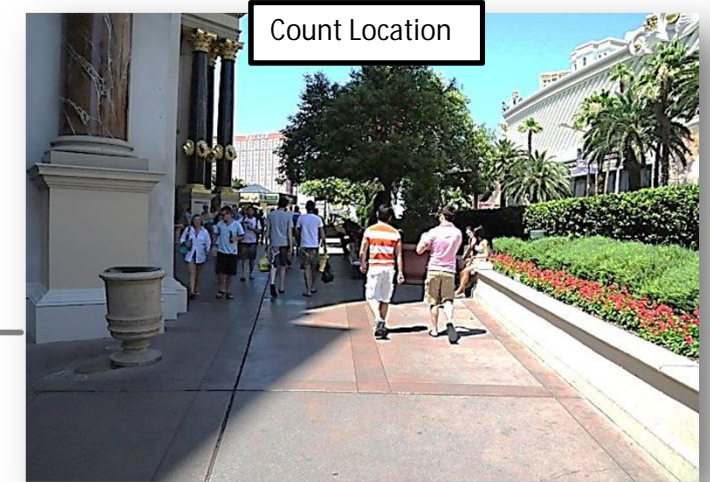

— Holiday Saturday
 5/26/2012
 - - - Typical Saturday
 6/16/2012
 - - - Level of Service
 Threshold

PEDESTRIAN VOLUME BY TIME OF DAY

Harrah's Hotel/Casino (Location ID: 14)
 Video Count Location: 1,870 ft. North of Flamingo Road
 Walkway Width (W) = 9.7 feet
 Effective Walkway Width (W_E) = 6.7 feet

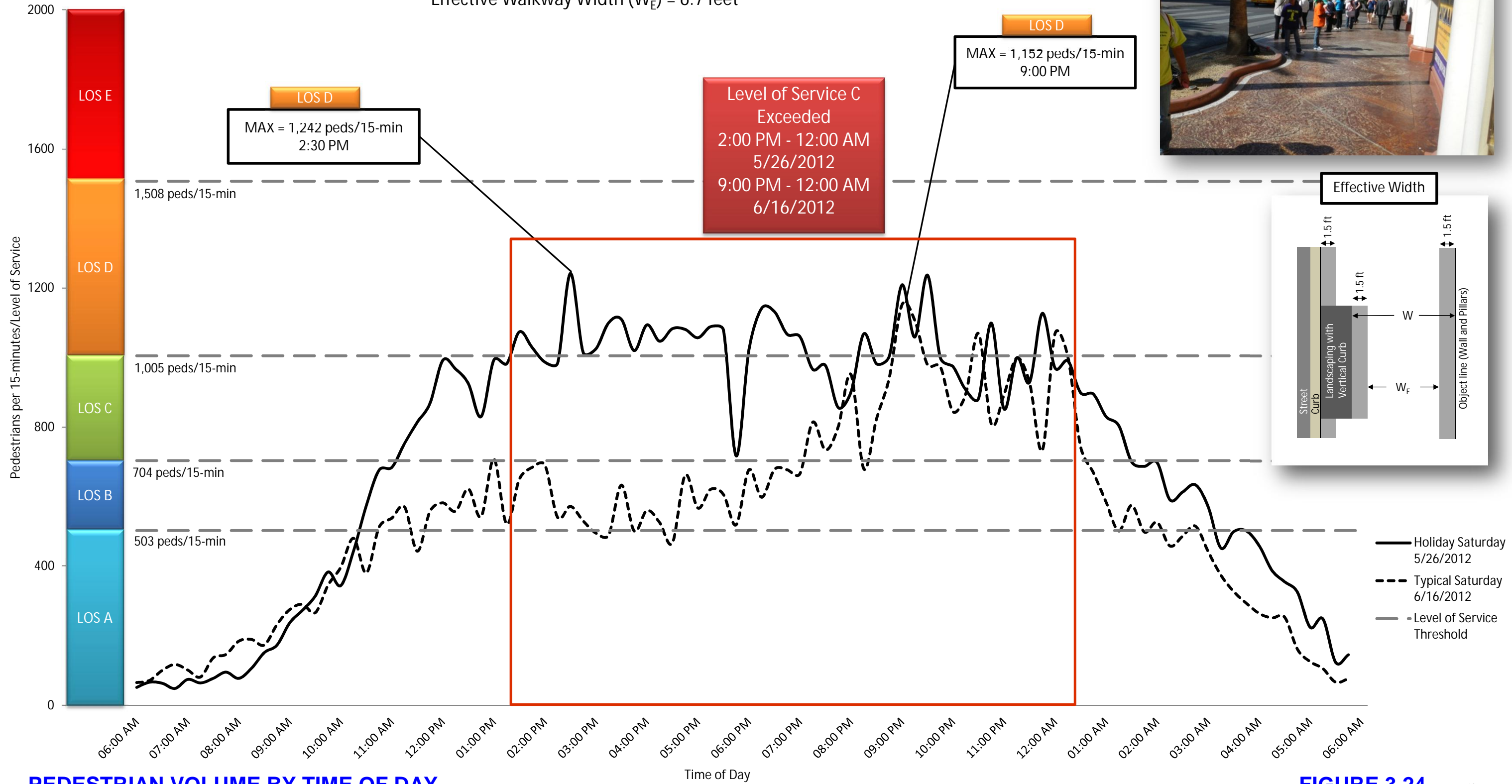
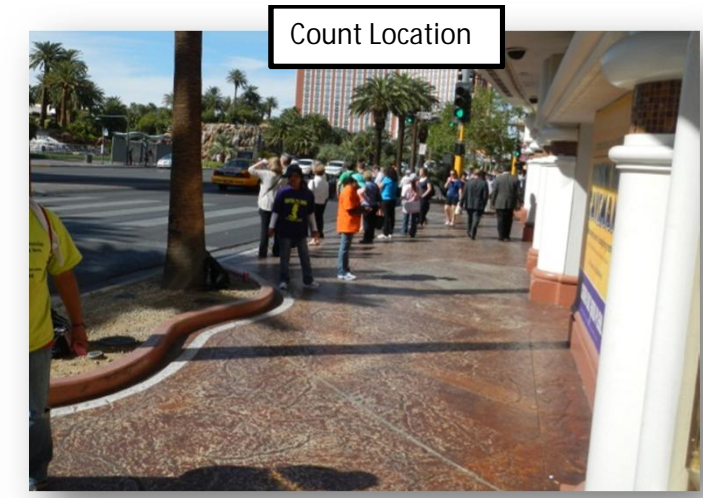

PEDESTRIAN VOLUME BY TIME OF DAY

Mirage Hotel/Casino (Location ID: 15)
 Video Count Location: 1,980 ft. South of Spring Mountain Road
 Walkway Width (W) = 11.7 feet
 Effective Walkway Width (W_E) = 8.7 feet

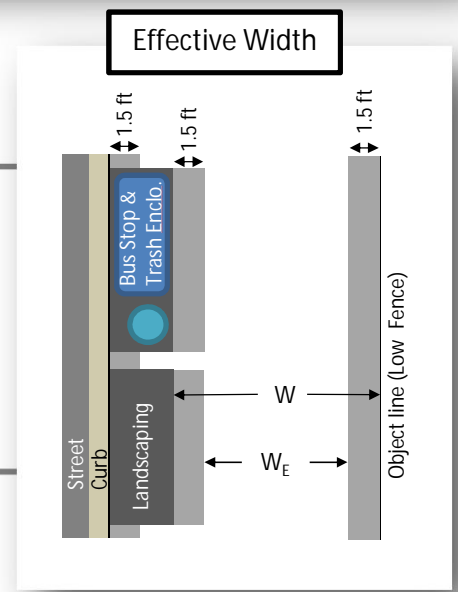
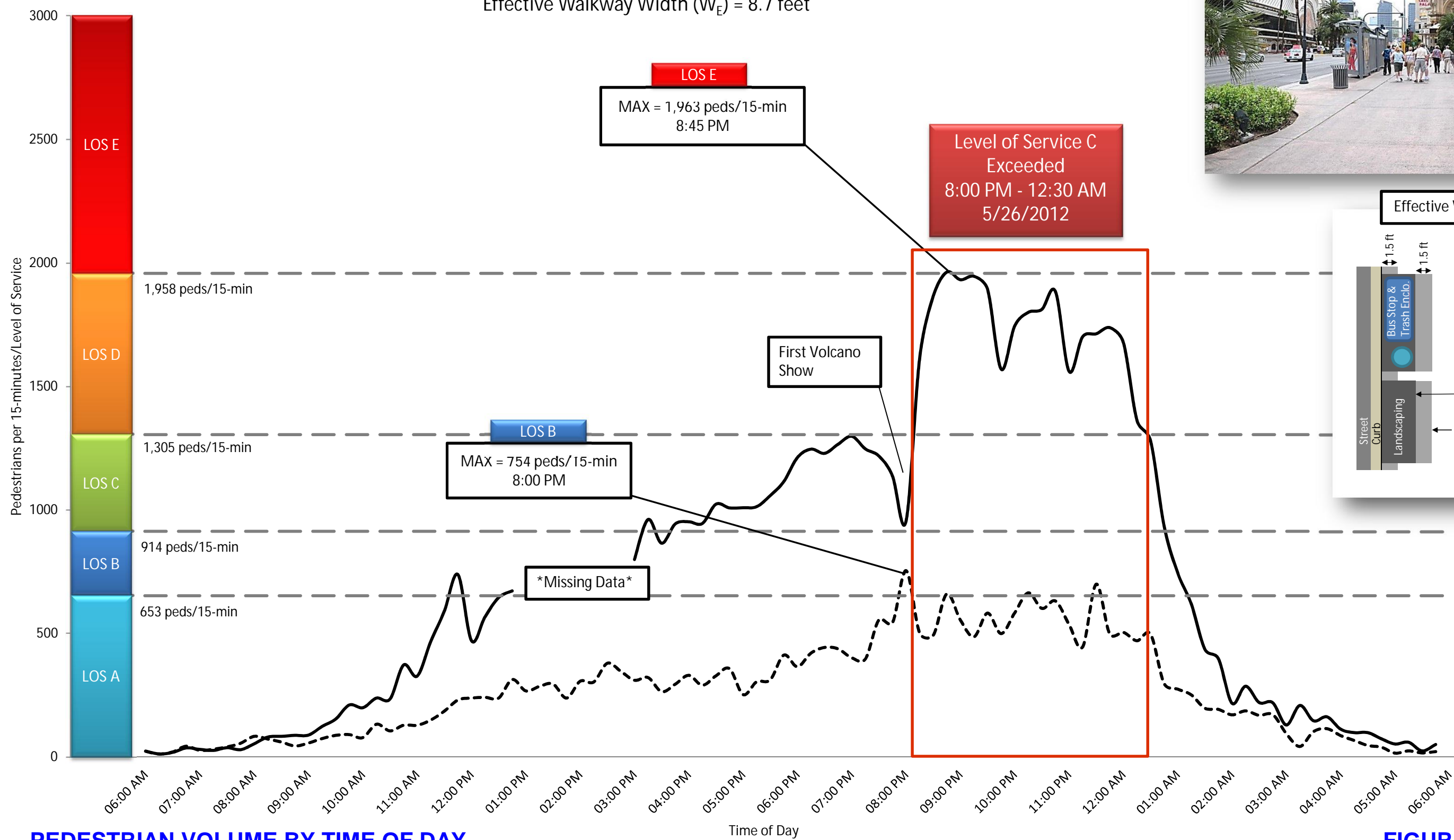

PEDESTRIAN VOLUME BY TIME OF DAY

Venetian Hotel/Casino (Location ID: CC3)
 Video Count Location: 1,750 ft. South of Spring Mountain Road
 Walkway Width (W) = 11.3 feet
 Effective Walkway Width (W_E) = 6.3 feet

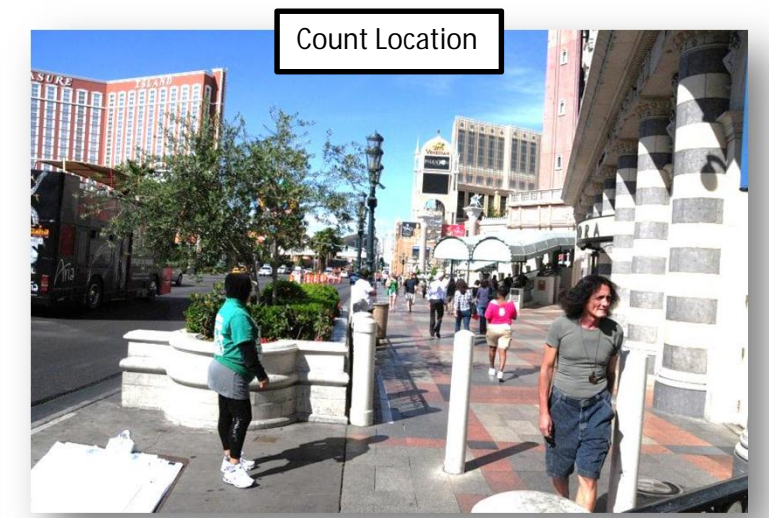

Count Location

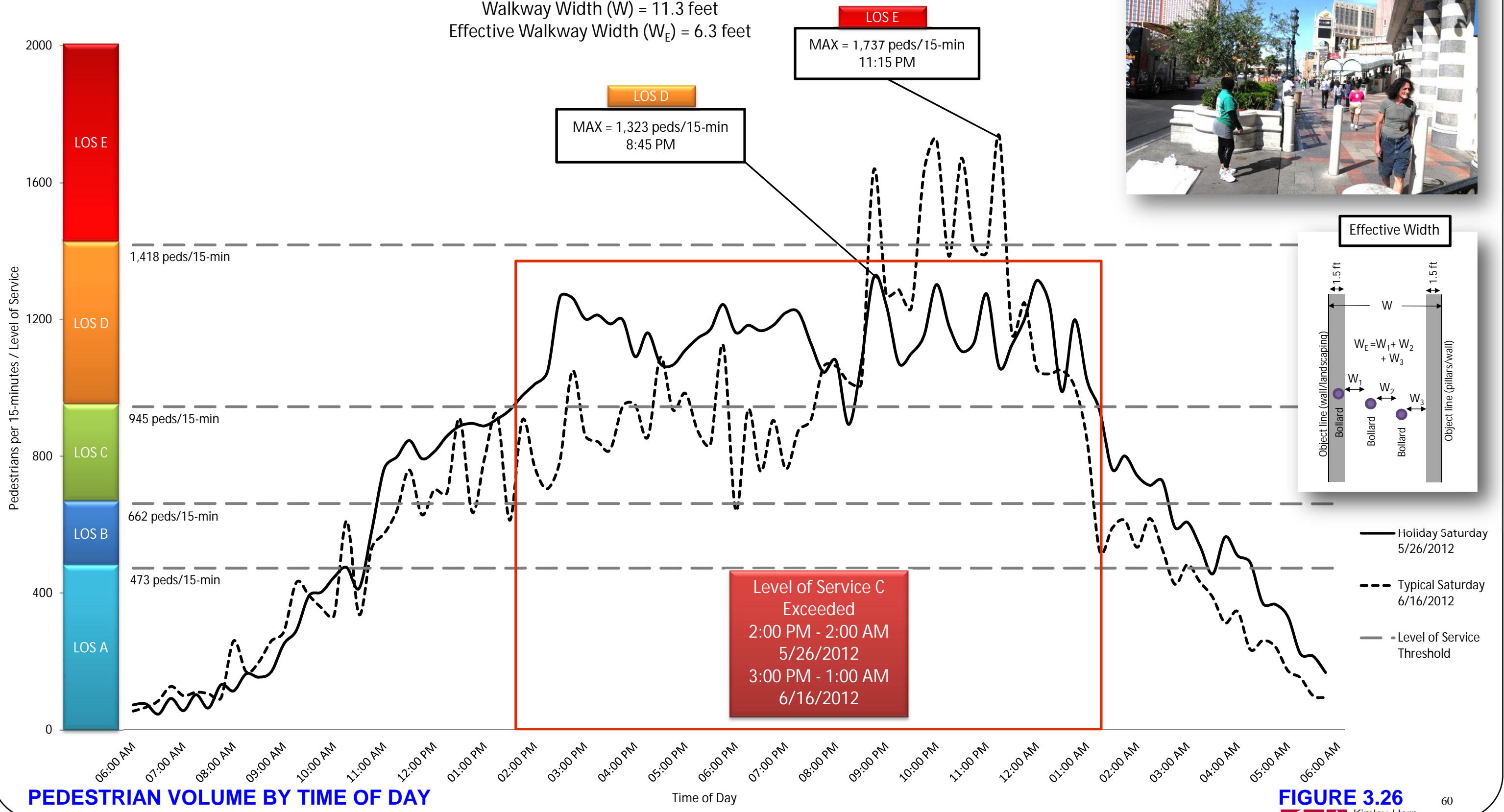

PEDESTRIAN VOLUME BY TIME OF DAY

FIGURE 3.26
 Kimley-Horn and Associates, Inc.

Treasure Island Hotel/Casino (Location ID: CC4)
 Video Count Location: 730 ft. South of Spring Mountain Road
 Walkway Width (W) = 4.7 feet
 Effective Walkway Width (W_E) = 1.7 feet



Count Location

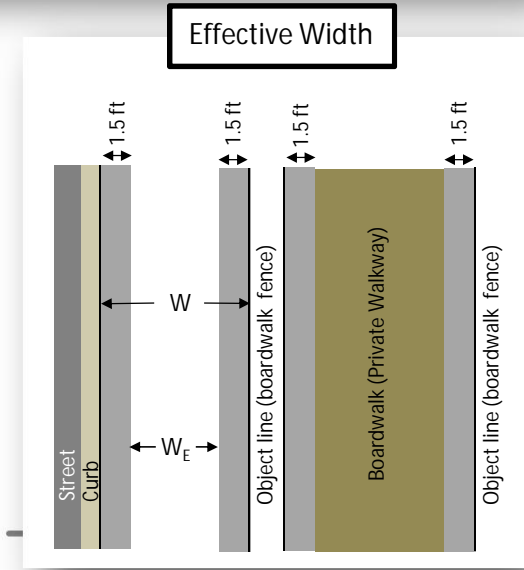
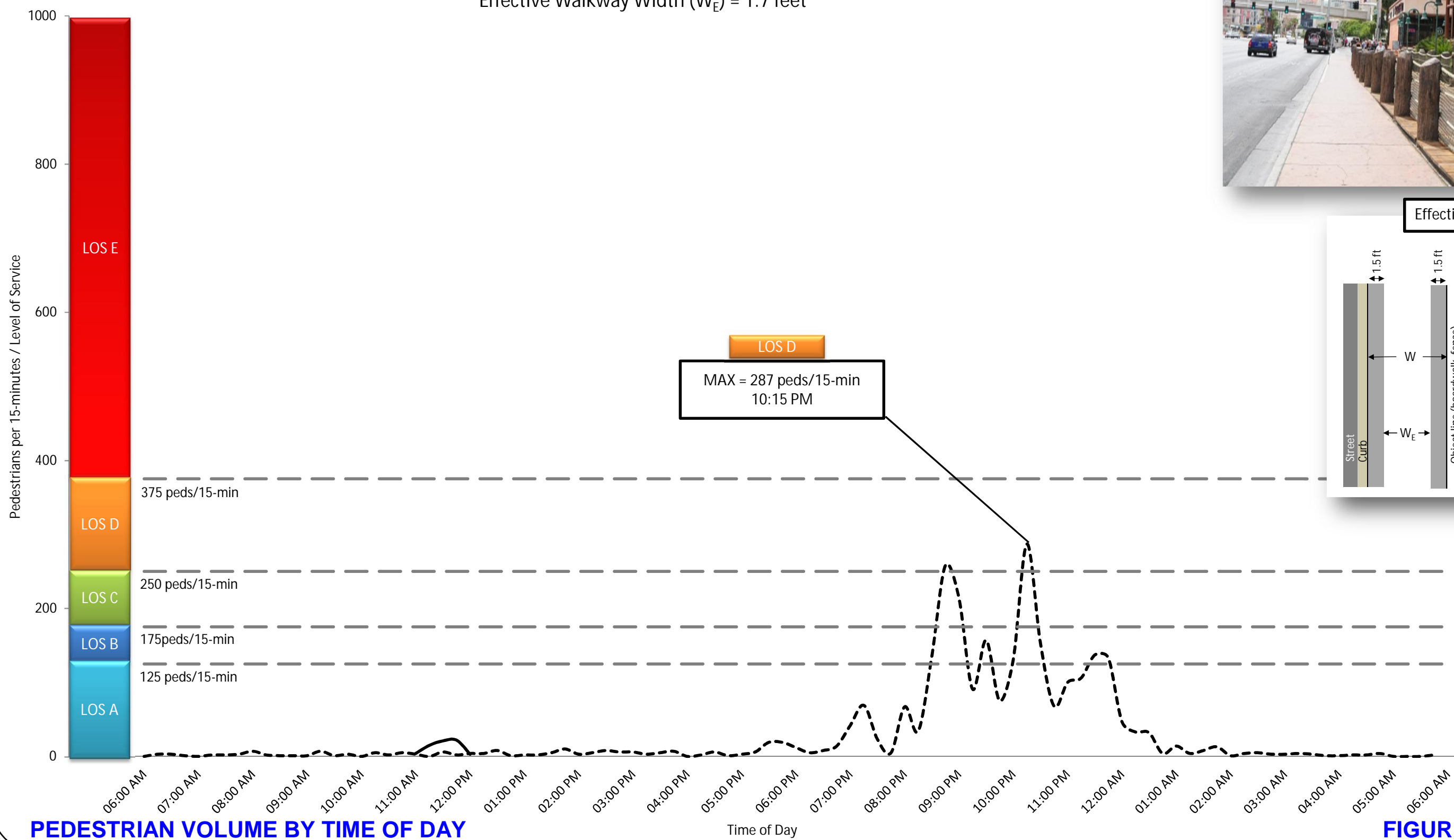

- Holiday Saturday 5/26/2012 Missing Data
- - - Typical Saturday 6/16/2012
- Level of Service Threshold

PEDESTRIAN VOLUME BY TIME OF DAY

3.1.4 Pedestrian Bridges

In general, the observed pedestrian bridges provided a LOS C or better on the holiday Saturday of May 26, 2012. The only exception was the Flamingo Road west pedestrian bridge (see Figure 3.36) where the maximum peak 15-minute pedestrian volume was observed with 2,172 pedestrians per 15-minutes between 9:15 PM and 9:30 PM. A daily total volume of 99,892 pedestrians for the holiday Saturday were observed using this bridge. The bridge provided a LOS D between the hours of 3:00 PM and about 11:30 PM, all other times a LOS C or better was observed. It should be noted that the LOS calculations were made assuming no non-permanent obstructions were on the bridge and that the entire walkway was available for pedestrian movement. Also, the Flamingo Road west pedestrian bridge was observed to have an average of three non-permanent obstructions on the bridge between 9:00 PM and 12:00 AM (see Figure 3.57). It should also be noted that in Section 3.6, when pedestrian volumes were estimated for the holiday Saturday, the Harmon Avenue West pedestrian bridge resulted in a calculated LOS which was also found to exceed LOS C (based on adjacent count volumes). Picture 3.10 and Picture 3.11 show the activity on pedestrian bridges in the study corridor.



Picture 3.10 – Flamingo Road West Pedestrian Bridge on Holiday Saturday.



Picture 3.11 – Flamingo Road East Pedestrian Bridge Escalators.

Table 3.3 summarizes the data collected at each of the pedestrian bridges for both the holiday and typical Saturdays (May 26 and June 16, 2012).

Pedestrian volume data was collected on 14 pedestrian bridges within the study corridor, which were:

- M3 – Tropicana Avenue South Pedestrian Bridge – Figure 3.28
- 2 – Tropicana Avenue West Pedestrian Bridge – Figure 3.29
- 3 – Tropicana Avenue East Pedestrian Bridge – Figure 3.30
- 4 – Tropicana Avenue North Pedestrian Bridge – Figure 3.31
- 7 – Harmon Avenue West Pedestrian Bridge – Figure 3.32
- M4 – Harmon Avenue North Pedestrian Bridge – Figure 3.33
- 8 - Flamingo Road South Pedestrian Bridge – Figure 3.34
- 10 - Flamingo Road East Pedestrian Bridge – Figure 3.35
- 11 - Flamingo Road West Pedestrian Bridge – Figure 3.36
- Metro2 - Flamingo Road North Pedestrian Bridge – Figure 3.37
- 16 – Venetian Pedestrian Bridge – Figure 3.38
- M7 - Spring Mountain West Pedestrian Bridge – Figure 3.39
- 17 - Spring Mountain East Pedestrian Bridge – Figure 3.40
- 19 – Wynn Pedestrian Bridge – Figure 3.41

Table 3.3 – Data Summary for Pedestrian Bridges.

Holiday Saturday - May 26, 2012											
West Side (and South Bridges)						East Side (and North Bridges)					
ID	Name	W _E	Max 15-min Volume	Time of Max Volume	LOS	ID	Name	W _E	Max 15-min Volume	Time of Max Volume	LOS
M3	Tropicana South	11.8	1036	9:15PM - 9:30PM	B	3	Tropicana East	11.8	1626	9:15PM - 9:30PM	C
8	Flamingo South	11.8	938	4:15PM - 4:30PM	A	4	Tropicana North	11.8	1205	5:15PM - 5:30PM	B
11	Flamingo West	12.0	2172	9:30PM - 9:45PM	D	M4	Harmon North	12.3	1549	5:30PM - 5:45PM	B
16	Venetian South	13.5	915	8:45PM - 9:00PM	A	10	Flamingo East	11.0	1549	12:15AM - 12:30AM	C
M7	Spring Mtn West	13.8	1038	8:45PM - 9:00PM	A	Metro2	Flamingo North	11.0	696	2:00PM - 2:15PM	A
						17	Spring Mtn East	17.0	916	4:00PM - 4:15PM	A
						19	Wynn North	11.8	1190	2:15PM - 2:30PM	B

Typical Saturday - June 16, 2012											
West Side (and South Bridges)						East Side (and North Bridges)					
ID	Name	W _E	Max 15-min Volume	Time of Max Volume	LOS	ID	Name	W _E	Max 15-min Volume	Time of Max Volume	LOS
M3	Tropicana South	11.8	460	11:15PM - 11:30PM	A	3	Tropicana East	11.8	518	12:00AM - 12:15AM	A
2	Tropicana West	11.8	1242	10:30PM - 10:45PM	C	4	Tropicana North	11.8	1220	12:00AM - 12:15AM	B
7	Harmon West	12.5	1599	9:30PM - 9:45PM	C	M4	Harmon North	12.3	1115	10:15PM - 10:30PM	A
8	Flamingo South	11.8	696	9:30PM - 9:45PM	B	10	Flamingo East	11.0	694	2:15PM - 2:30PM	A
11	Flamingo West	12.0	1570	9:15PM - 9:30PM	C	Metro2	Flamingo North	11.0	971	10:00PM - 10:15PM	B
16	Venetian South	13.5	720	9:00PM - 9:15PM	A	17	Spring Mtn East	17.0	673	2:00PM - 2:15PM	A
M7	Spring Mtn West	13.8	802	8:45PM - 9:00PM	A	19	Wynn North	11.8	514	2:30PM - 2:45PM	A

Tropicana Avenue South Pedestrian Bridge (Location ID: M3)

Manual Count Location: On Bridge

Walkway Width (W) = 14 feet

Effective Walkway Width (W_E) = 11.8 feet

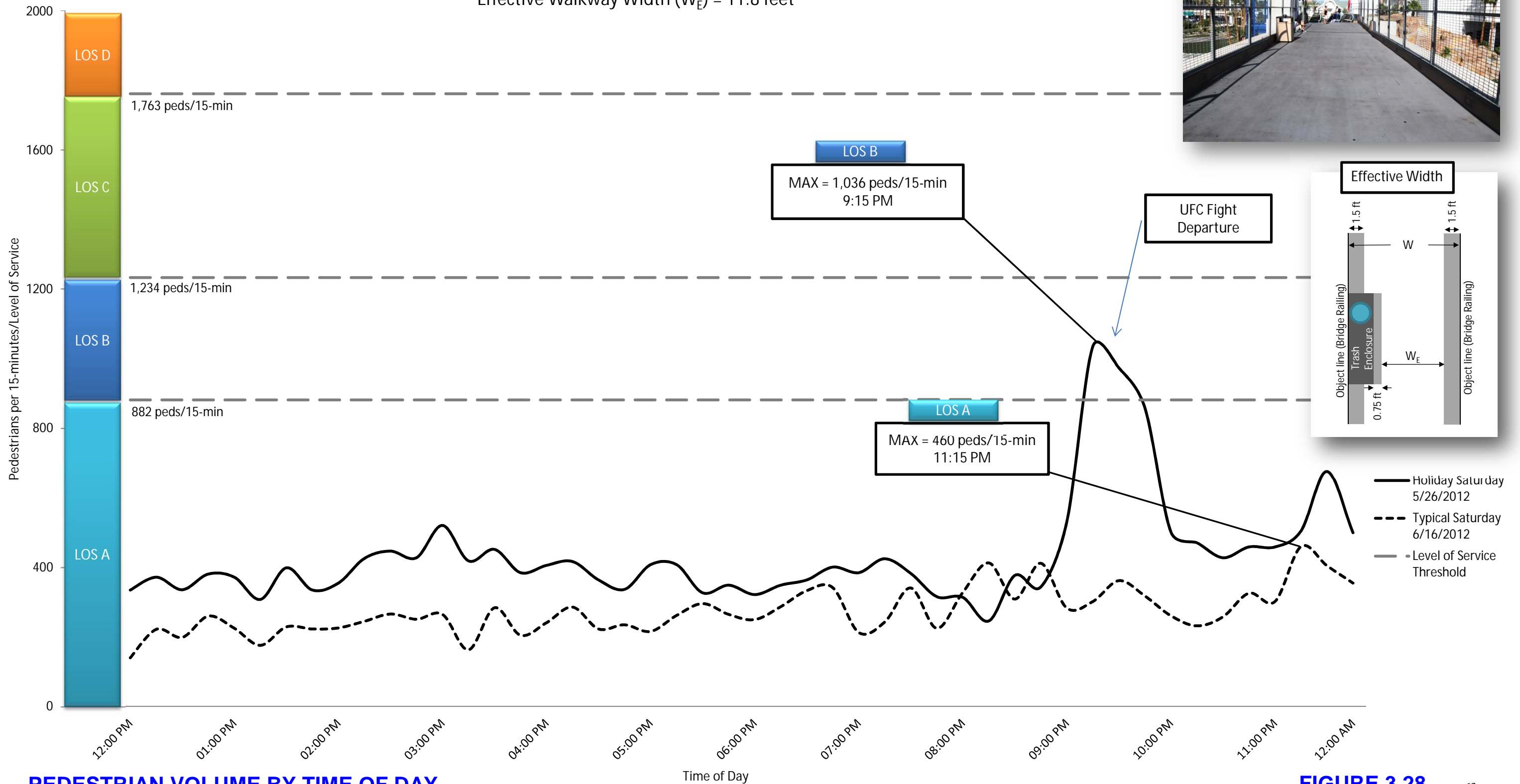

PEDESTRIAN VOLUME BY TIME OF DAY

FIGURE 3.28

Tropicana Avenue West Pedestrian Bridge (Location ID: 2)

Video Count Location: On Bridge

Walkway Width (W) = 14 feet

Effective Walkway Width (W_E) = 11.8 feet

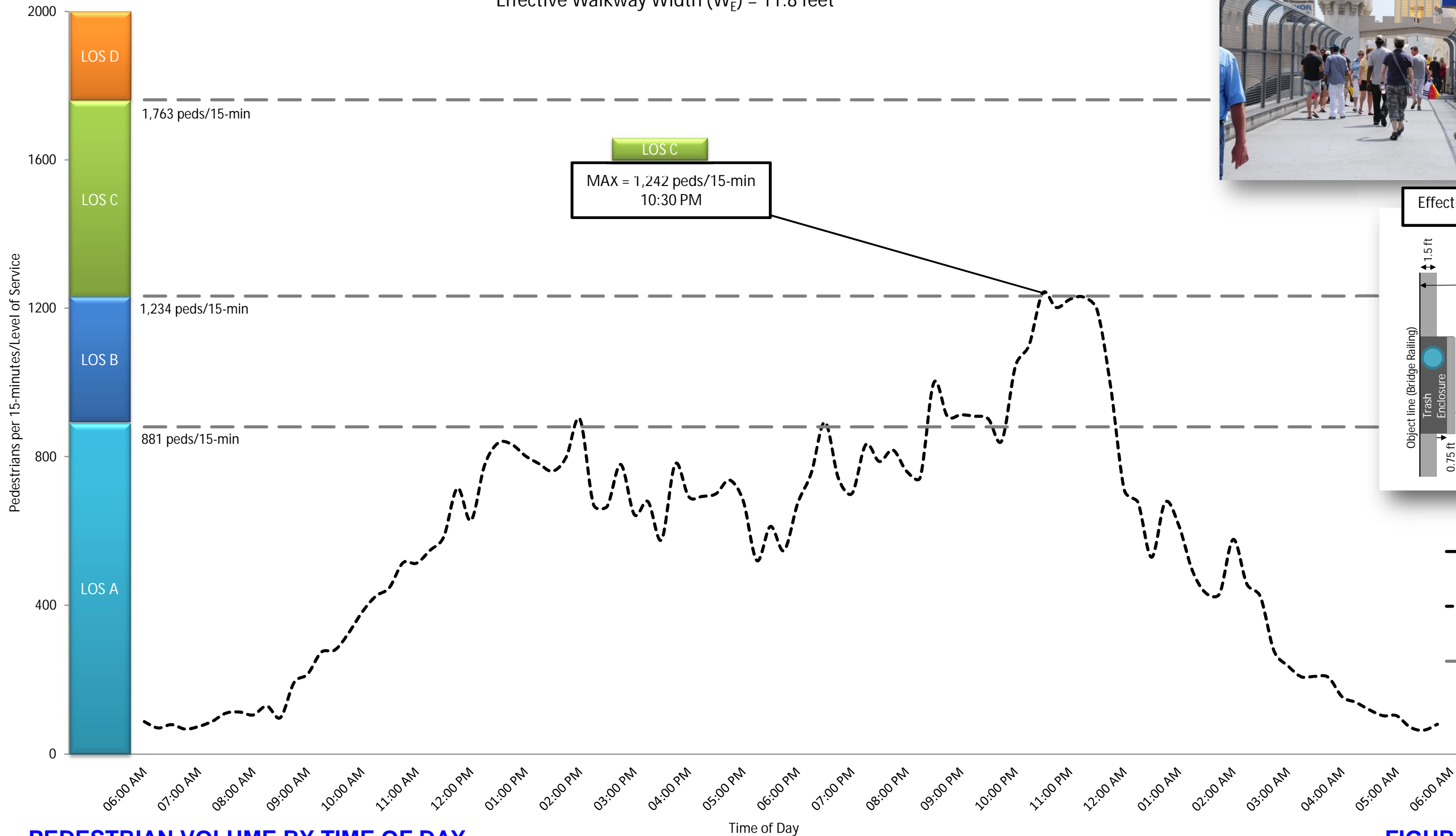

Count Location

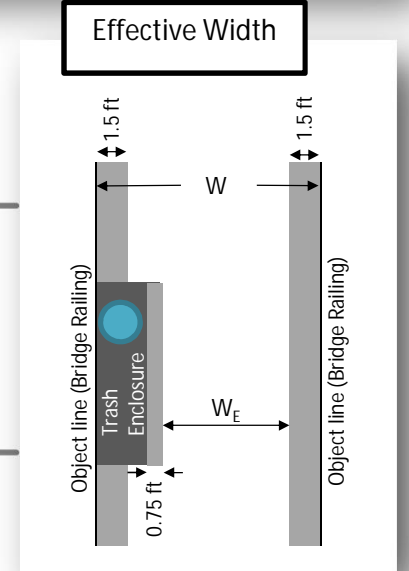

Effective Width

- Holiday Saturday 5/26/2012 Not Collected
- - - Typical Saturday 6/16/2012
- - - Level of Service Threshold

PEDESTRIAN VOLUME BY TIME OF DAY

Tropicana Avenue East Pedestrian Bridge (Location ID: 3)

Video Count Location: On Bridge

Walkway Width (W) = 14 feet

Effective Walkway Width (W_E) = 11.8 feet



Count Location

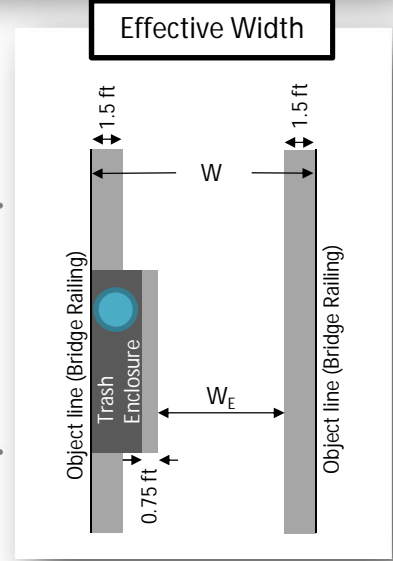
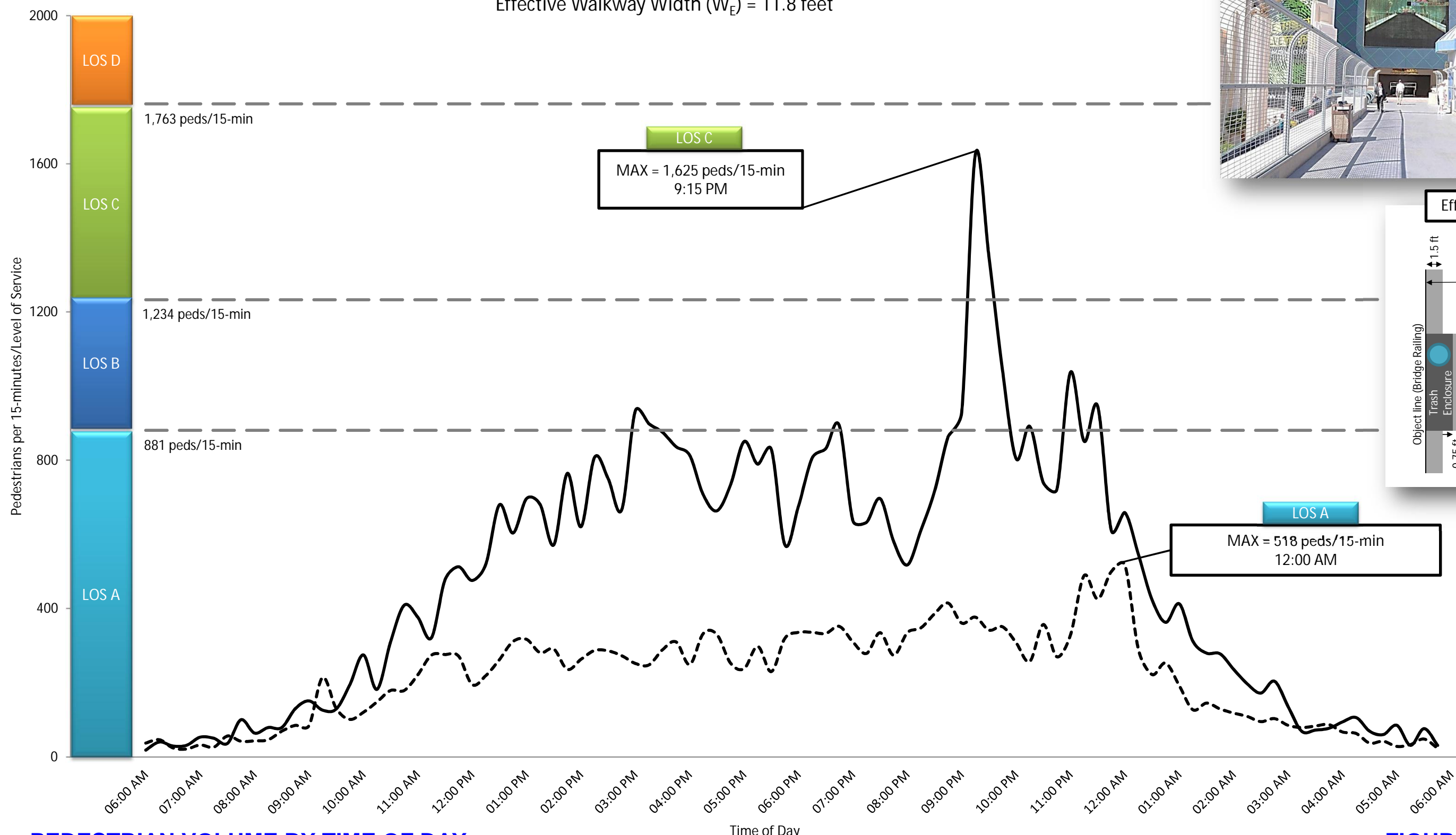

- Holiday Saturday 5/26/2012
- - - Typical Saturday 6/16/2012
- - - Level of Service Threshold

PEDESTRIAN VOLUME BY TIME OF DAY

Tropicana Avenue North Pedestrian Bridge (Location ID: 4)

Video Count Location: On Bridge

Walkway Width (W) = 14 feet

Effective Walkway Width (W_E) = 11.8 feet

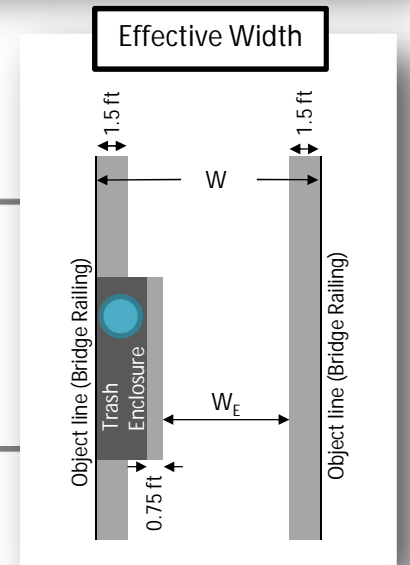
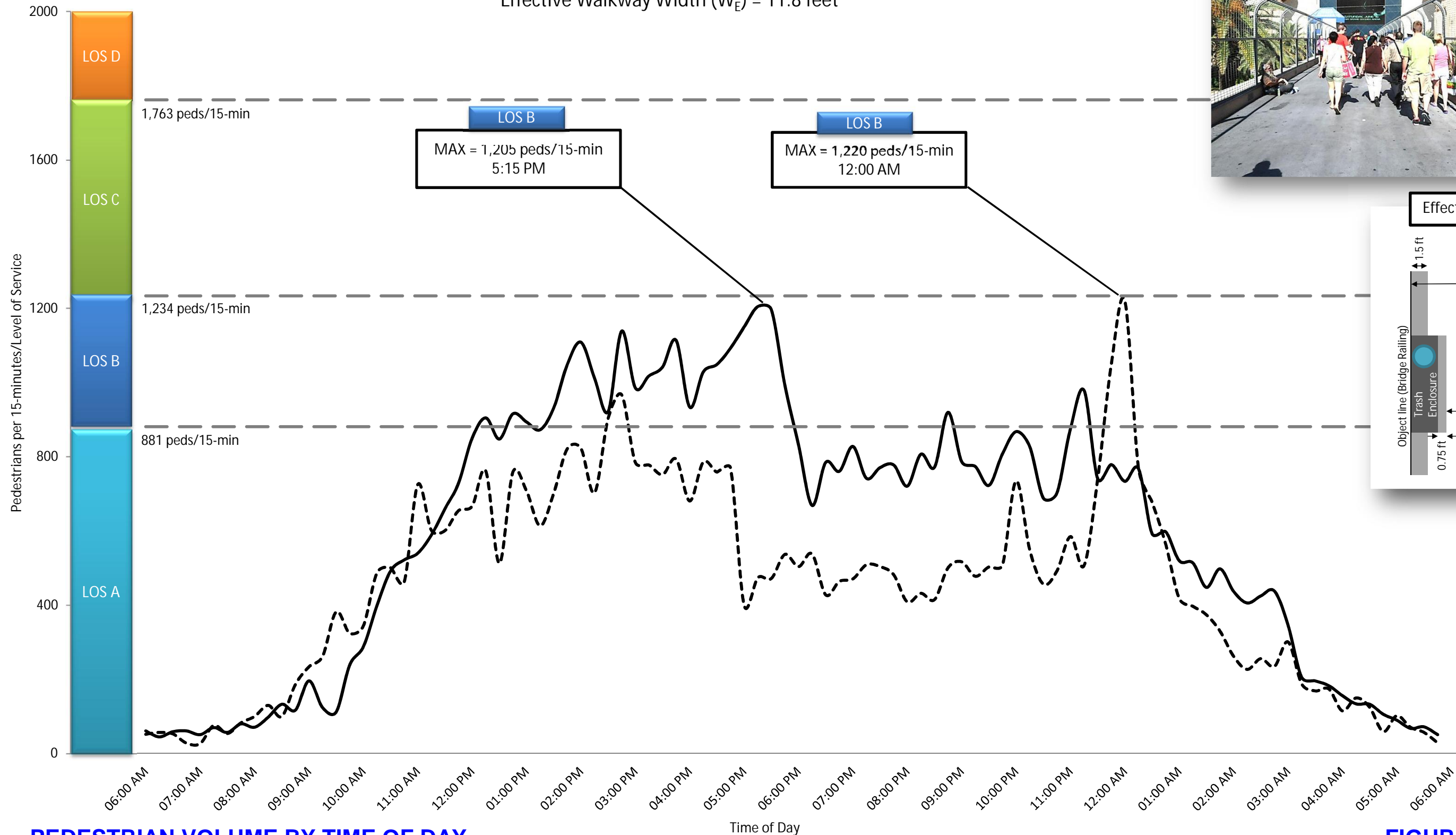

- Holiday Saturday 5/26/2012
- - - Typical Saturday 6/16/2012
- - - Level of Service Threshold

PEDESTRIAN VOLUME BY TIME OF DAY

Harmon Avenue West Pedestrian Bridge (Location ID: 7)

Video Count Location: On Bridge

Walkway Width (W) = 15.5 feet

Effective Walkway Width (W_E) = 12.5 feet

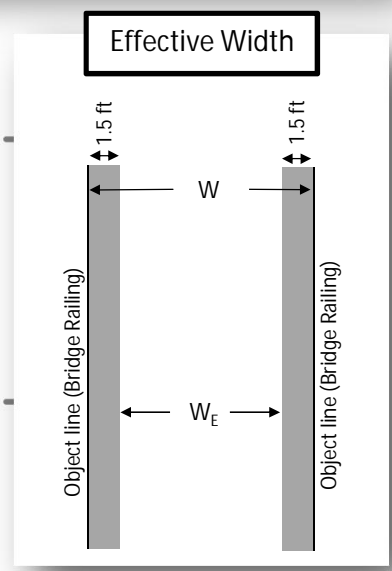
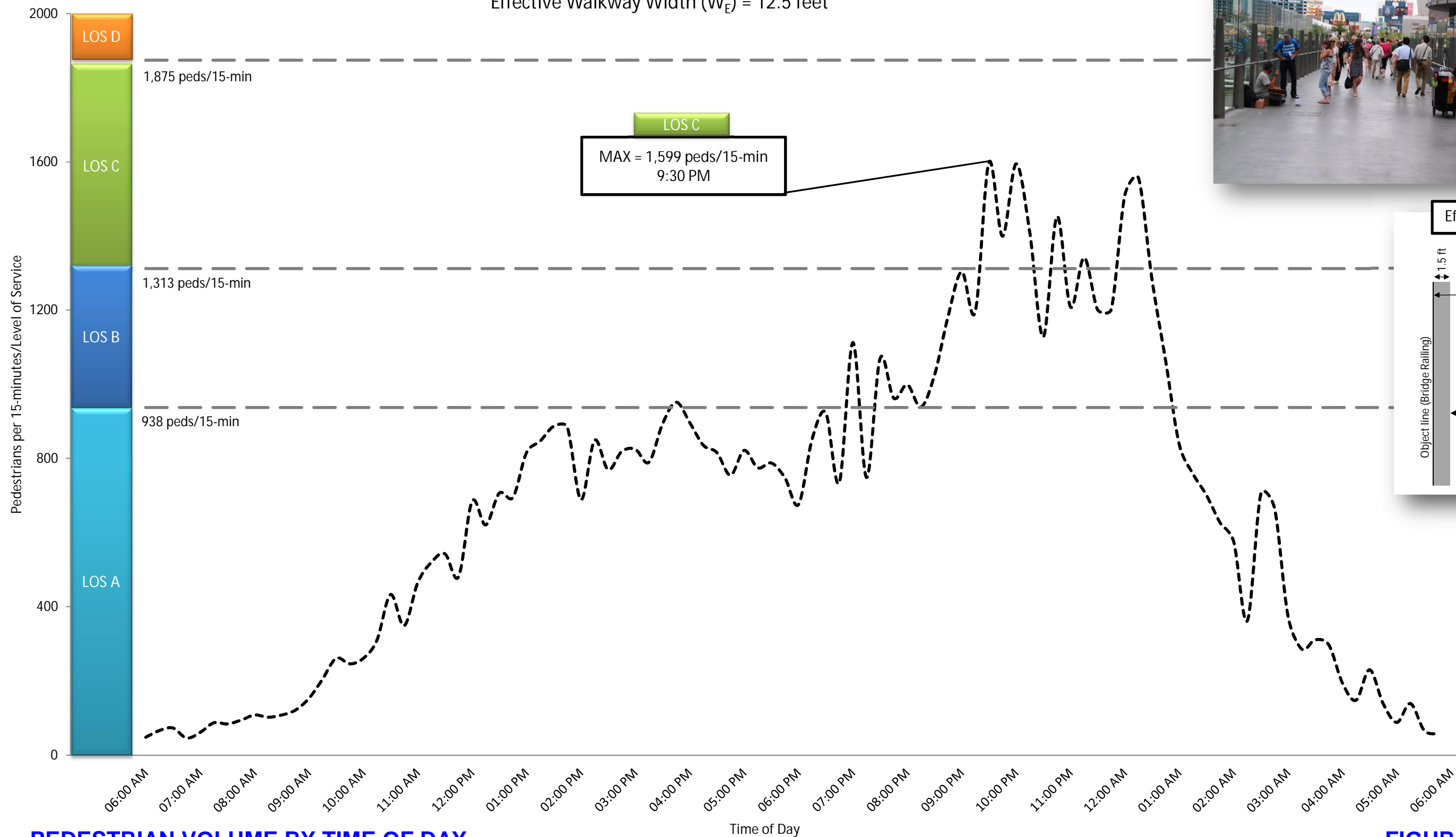

- Holiday Saturday
5/26/2012 Not Collected
- - - Typical Saturday
6/16/2012
- - - Level of Service
Threshold

PEDESTRIAN VOLUME BY TIME OF DAY

Harmon Avenue North Pedestrian Bridge (Location ID: M4)

Manual Count Location: On Bridge

Walkway Width (W) = 15.3 feet

Effective Walkway Width (W_E) = 12.3 feet

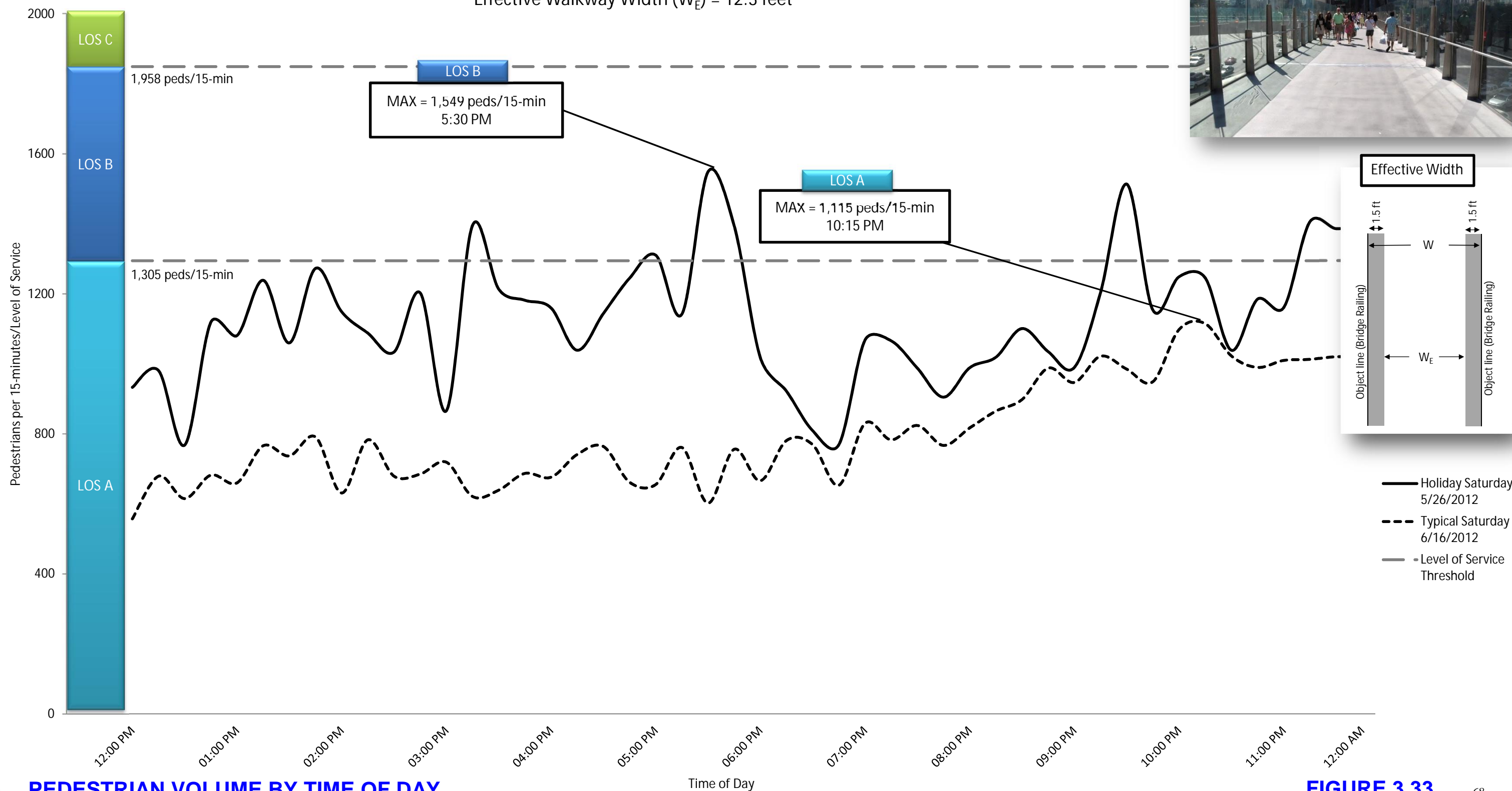

PEDESTRIAN VOLUME BY TIME OF DAY

FIGURE 3.33

Flamingo Road South Pedestrian Bridge (Location ID: 8)

Video Count Location: On Bridge

Walkway Width (W) = 14.8 feet

Effective Walkway Width (W_E) = 11.8 feet

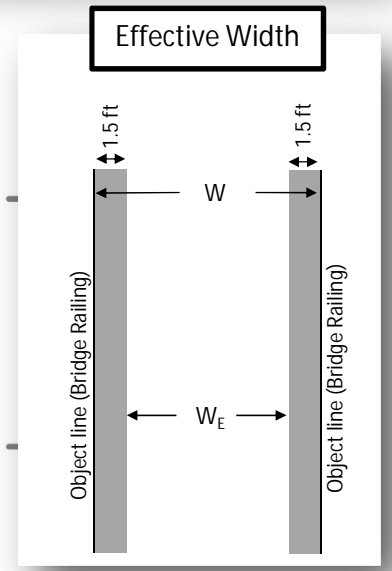
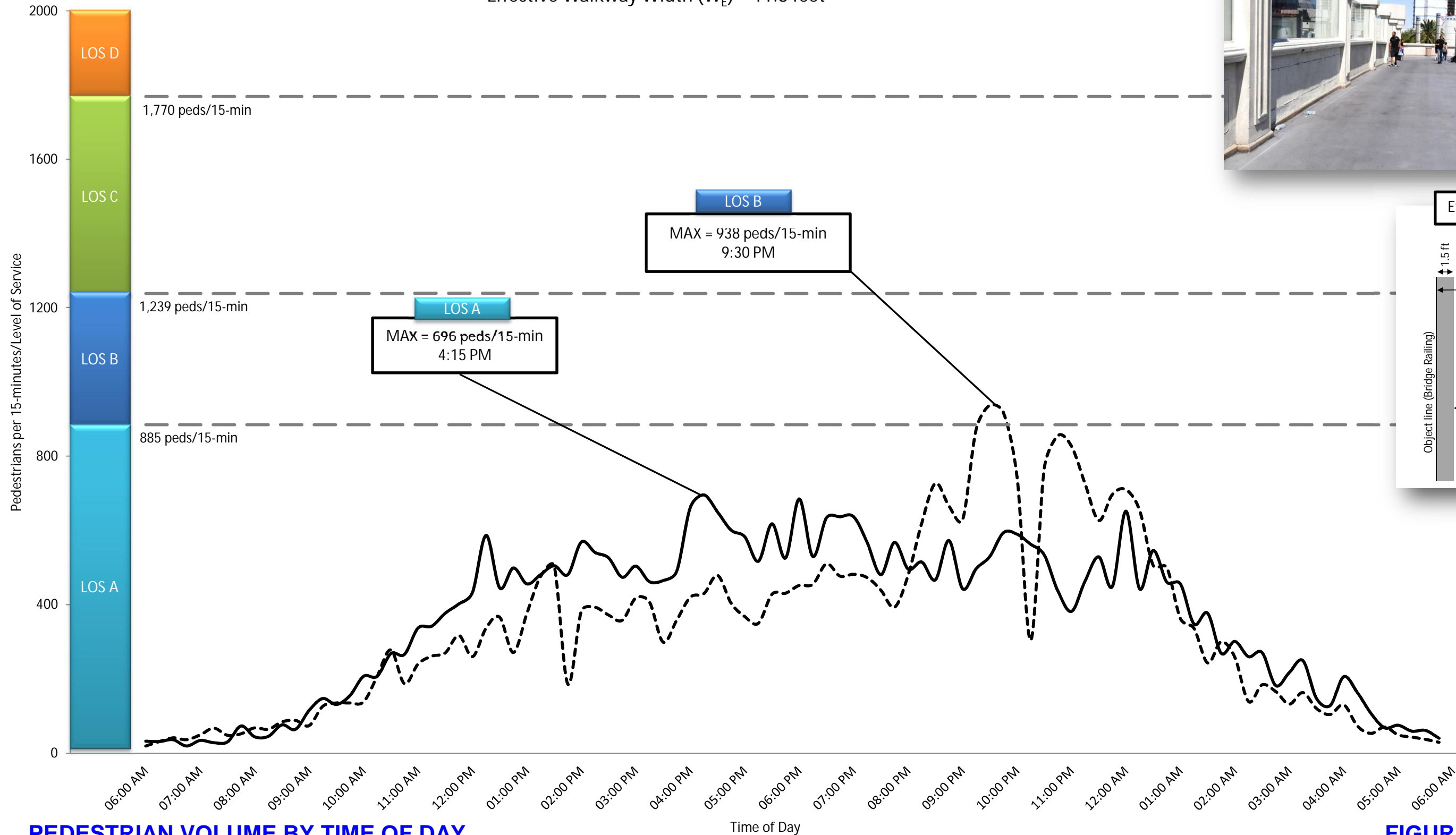

- Holiday Saturday 5/26/2012
- - - Typical Saturday 6/16/2012
- - - Level of Service Threshold

PEDESTRIAN VOLUME BY TIME OF DAY

Flamingo Road East Pedestrian Bridge (Location ID: 10)

Video Count Location: On Bridge

Walkway Width (W) = 14 feet

Effective Walkway Width (W_E) = 11 feet

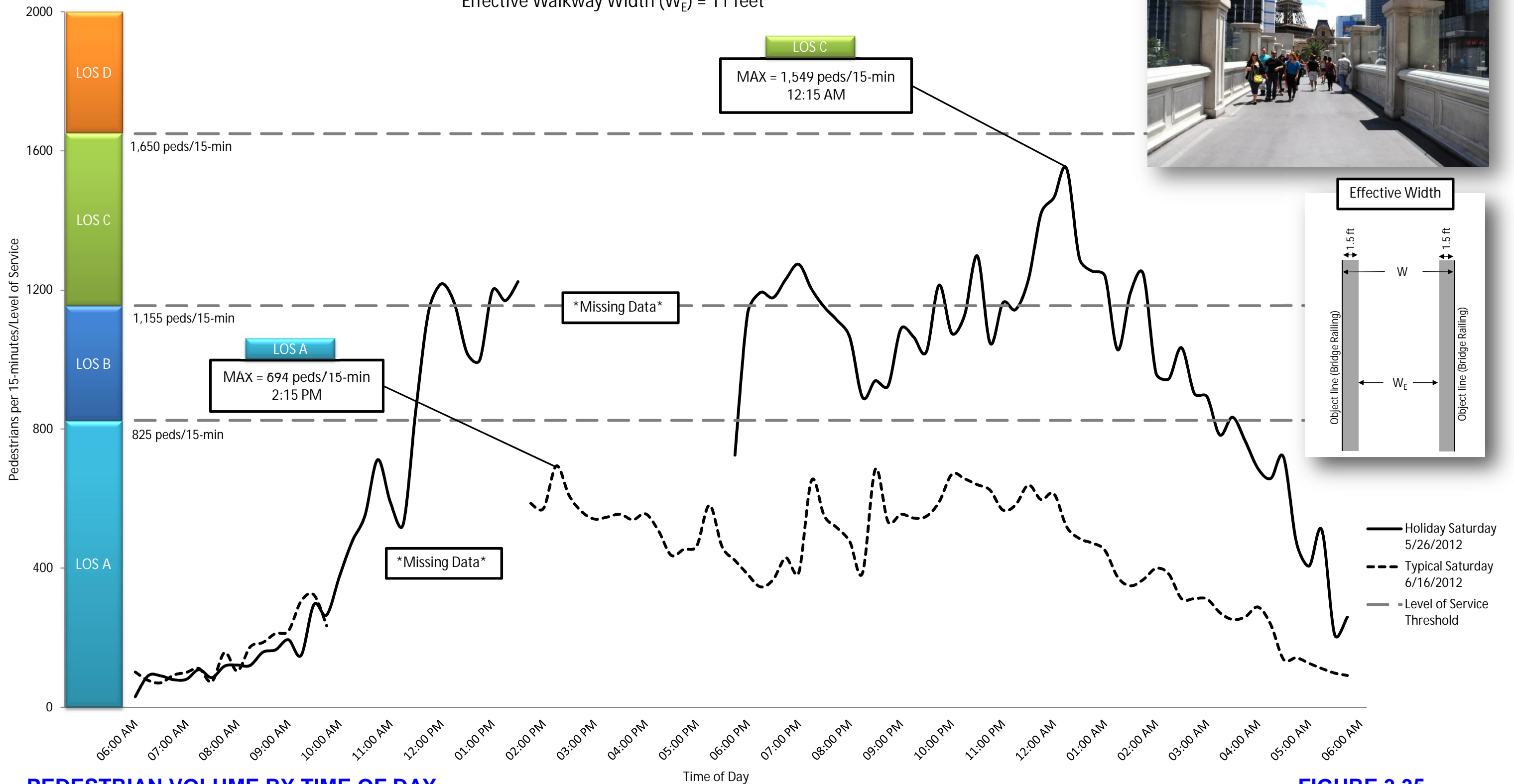
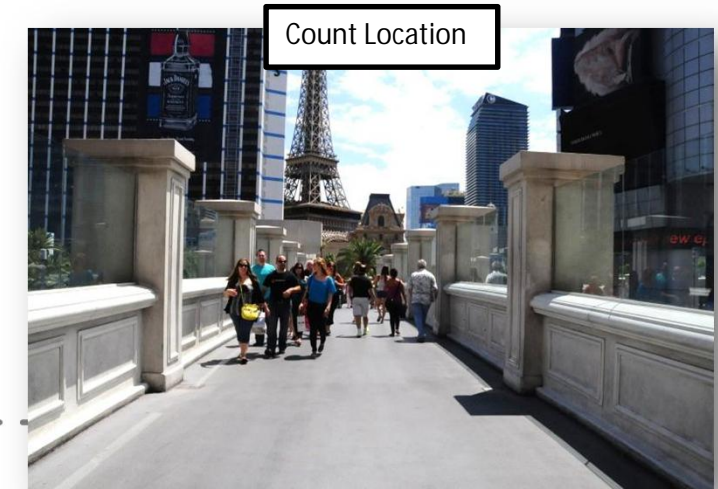

PEDESTRIAN VOLUME BY TIME OF DAY

Flamingo Road West Pedestrian Bridge (Location ID: 11)

Video Count Location: On Bridge

Walkway Width (W) = 15 feet

Effective Walkway Width (W_E) = 12 feet

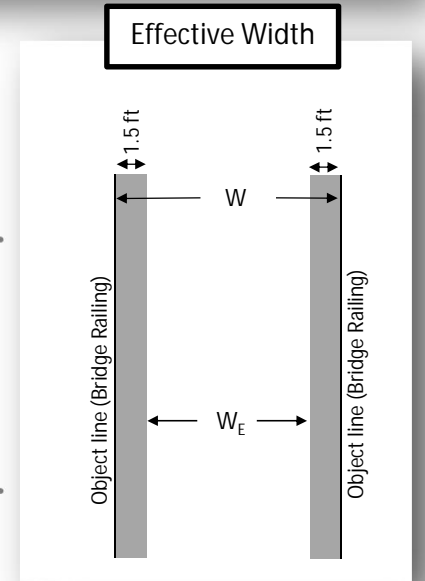
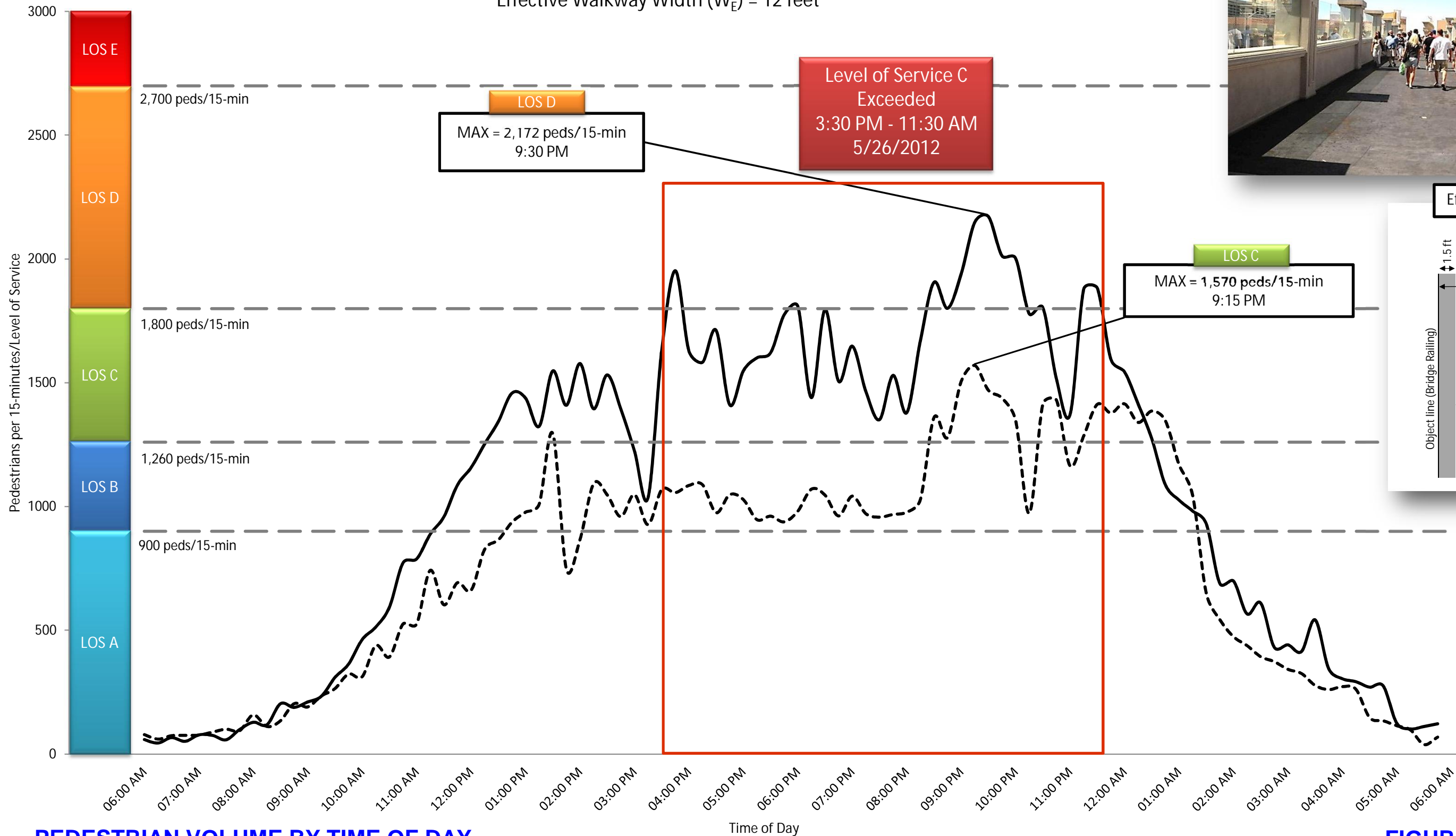

PEDESTRIAN VOLUME BY TIME OF DAY

Flamingo Road North Pedestrian Bridge (Location ID: Metro2)

Video Count Location: On Bridge

Walkway Width (W) = 14 feet

Effective Walkway Width (W_E) = 11 feet

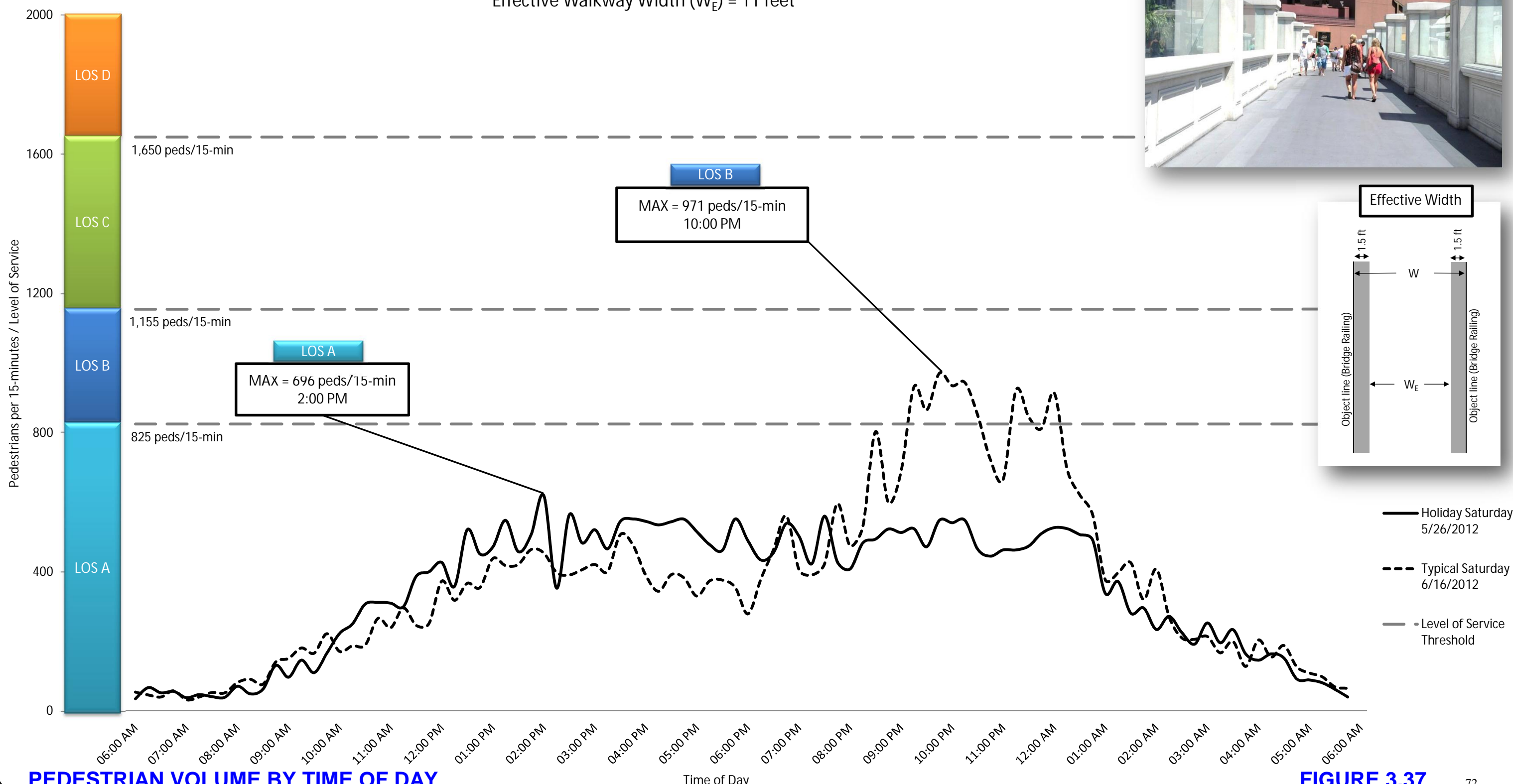

PEDESTRIAN VOLUME BY TIME OF DAY

FIGURE 3.37

Venetian Pedestrian Bridge (Location ID: 16)

Video Count Location: On Bridge

Walkway Width (W) = 16.5 feet

Effective Walkway Width (W_E) = 13.5 feet

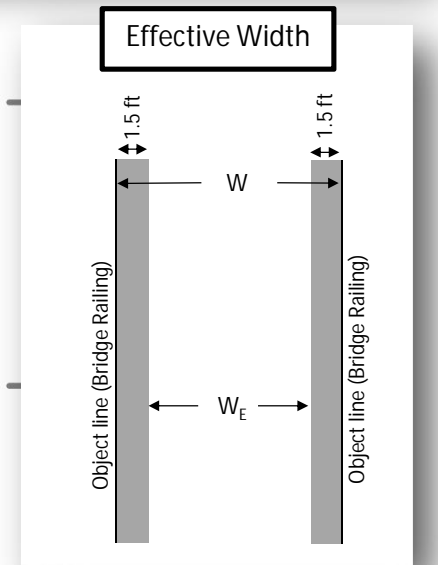
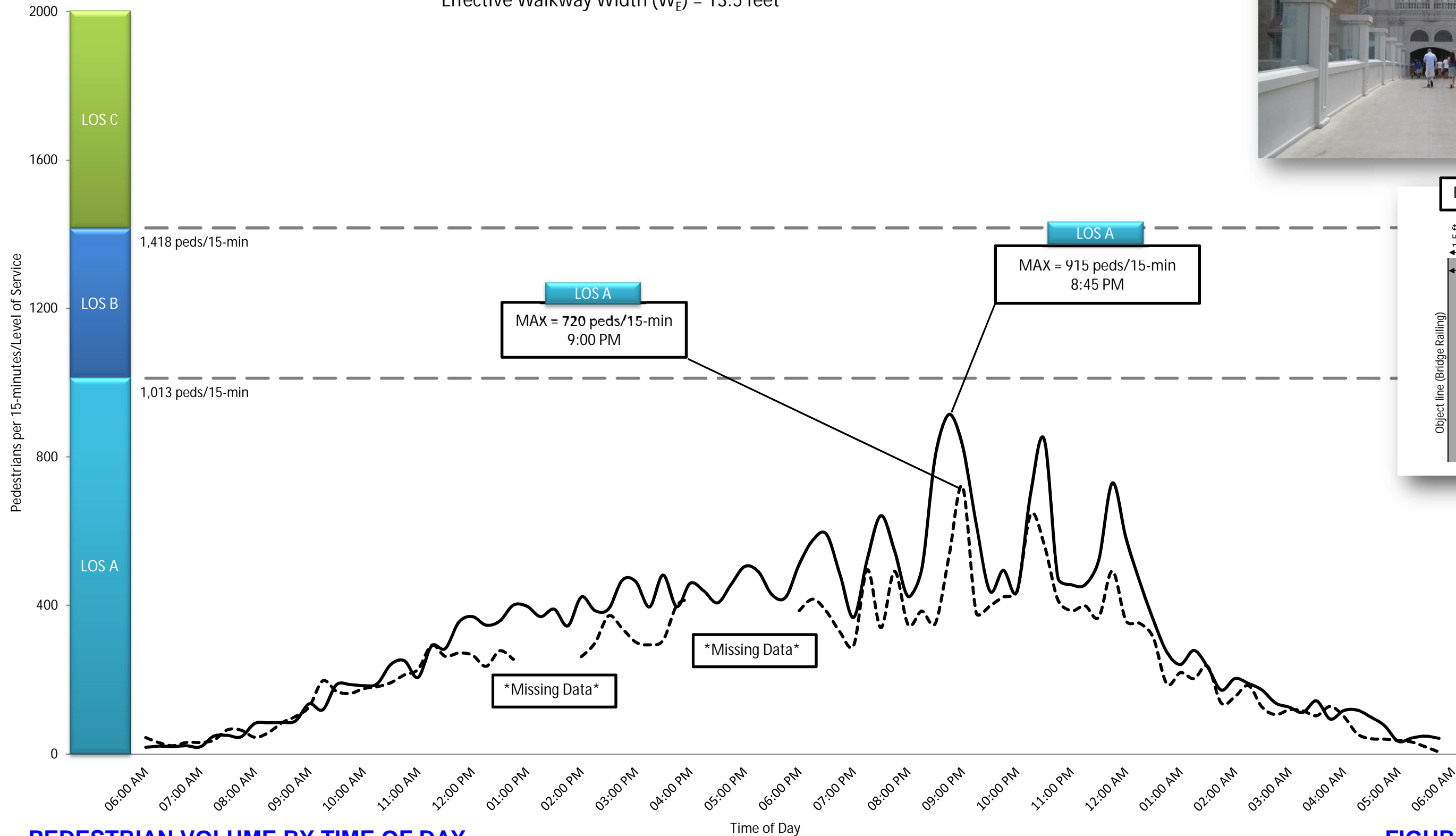
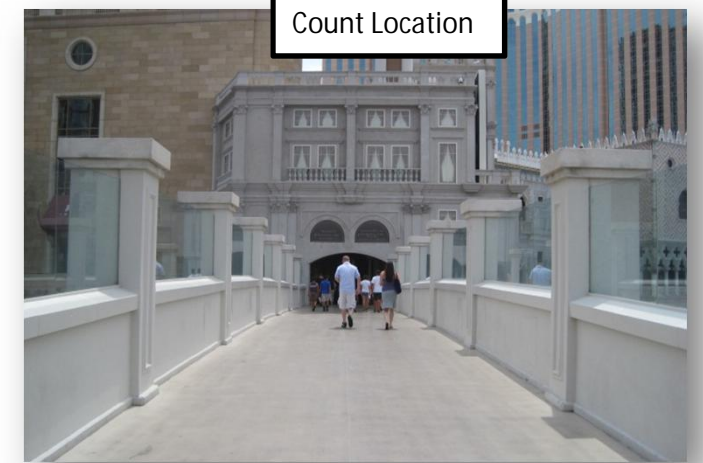

PEDESTRIAN VOLUME BY TIME OF DAY

Spring Mountain Road West Pedestrian Bridge (Location ID: M7)

Manual Count Location: On Bridge
 Walkway Width (W) = 16.8 feet
 Effective Walkway Width (W_E) = 13.8 feet

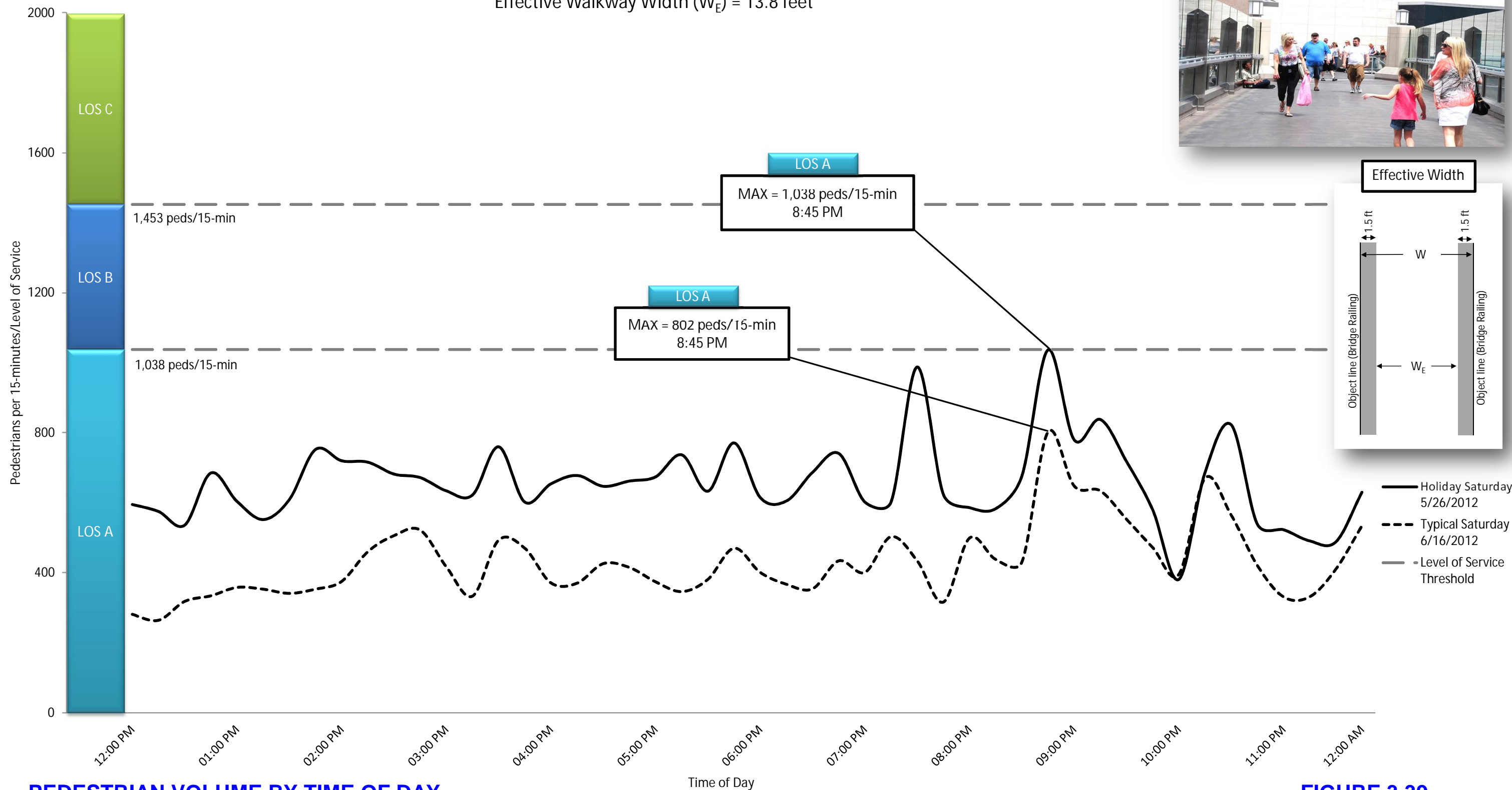

PEDESTRIAN VOLUME BY TIME OF DAY

FIGURE 3.39

Spring Mountain Road East Pedestrian Bridge (Location ID: 17)

Video Count Location: On Bridge
 Walkway Width (W) = 20 feet
 Effective Walkway Width (W_E) = 17 feet

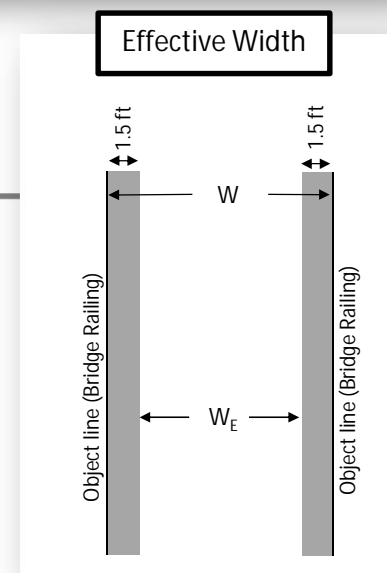
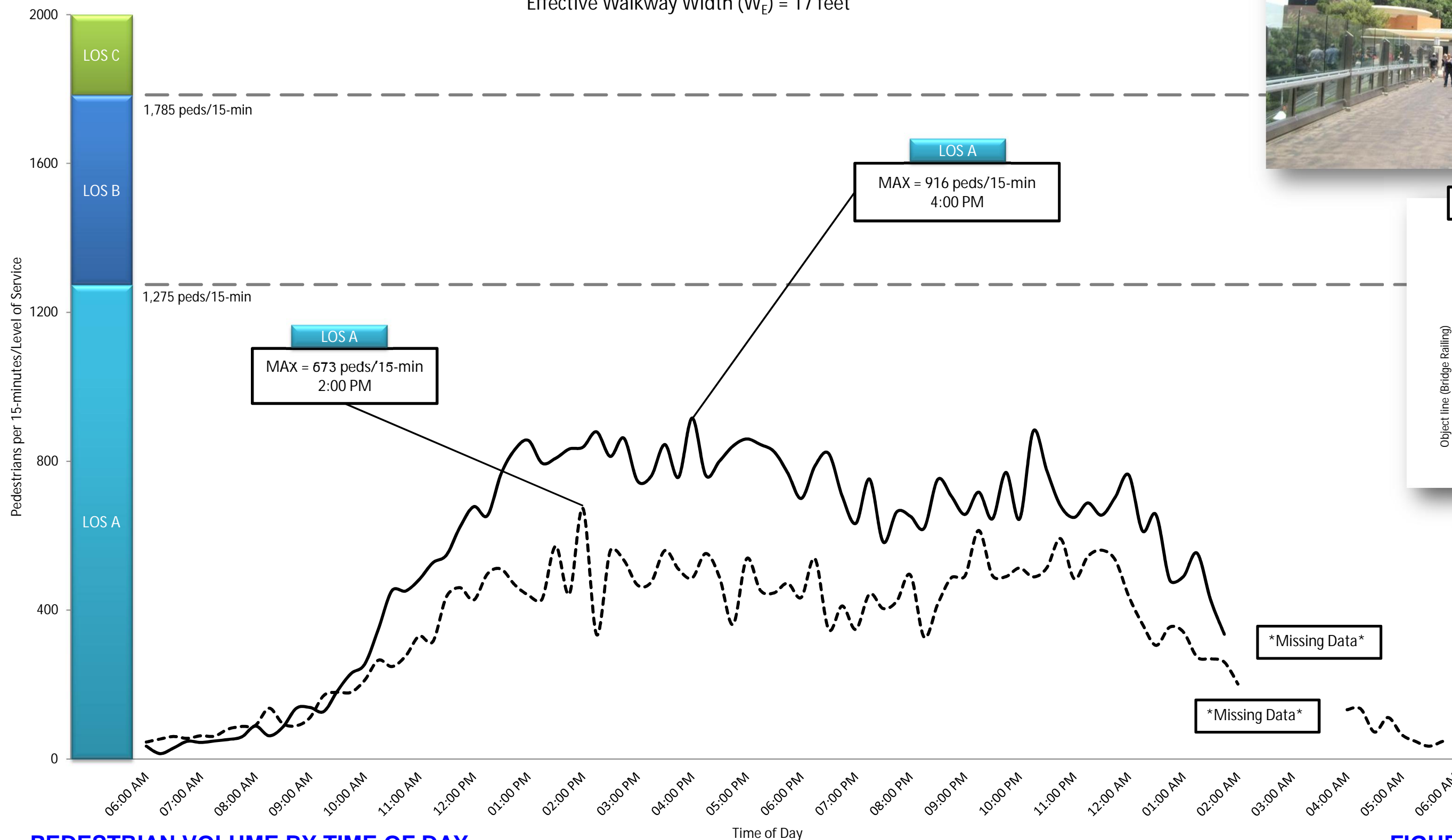

- Holiday Saturday 5/26/2012
- - - Typical Saturday 6/16/2012
- Level of Service Threshold

PEDESTRIAN VOLUME BY TIME OF DAY

Wynn Pedestrian Bridge (Location ID: 19)
 Video Count Location: Stair/Escalator at Bridge Access
 Walkway Width (W) = 14.8 feet
 Effective Walkway Width (W_E) = 11.8 feet

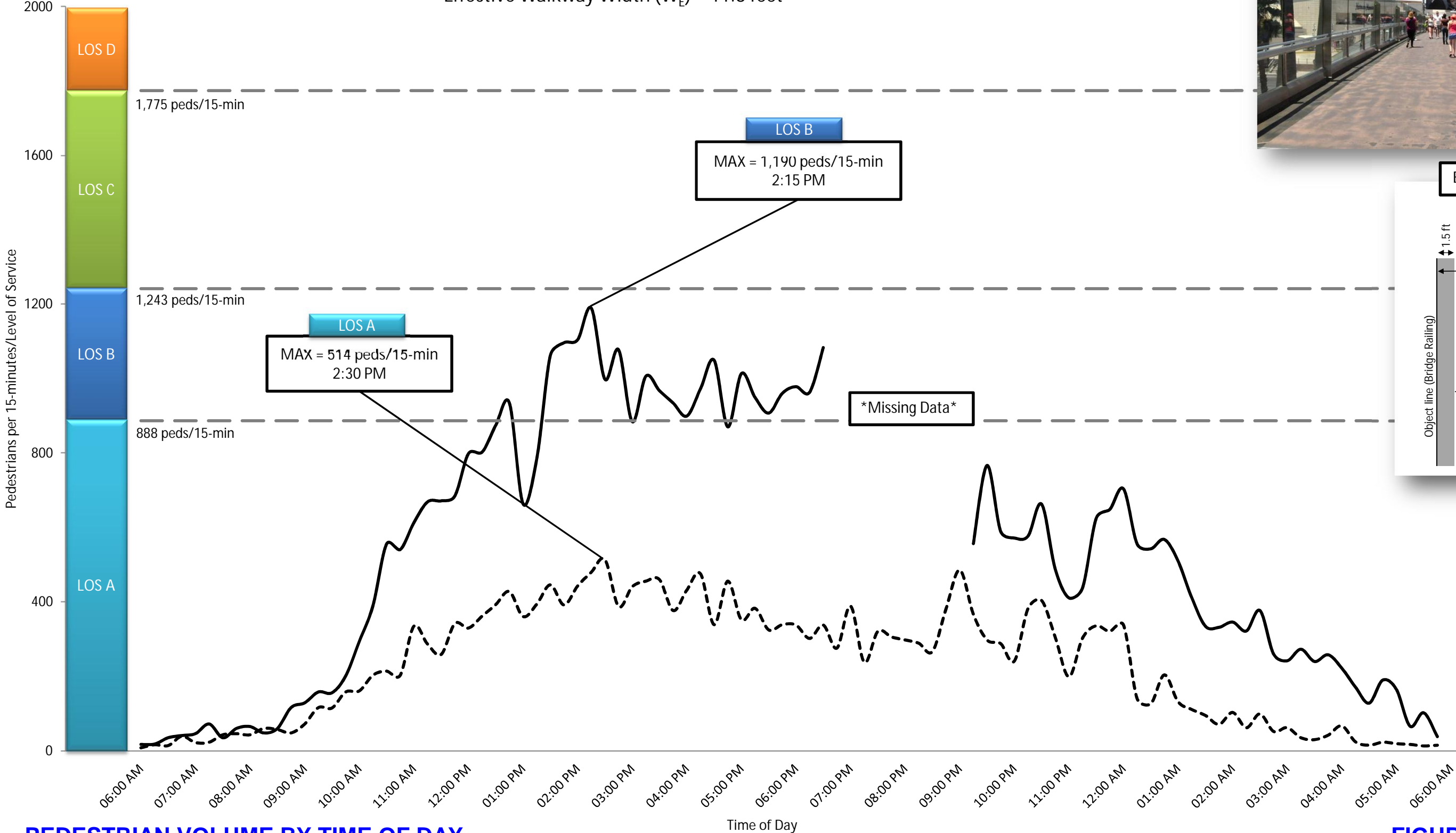
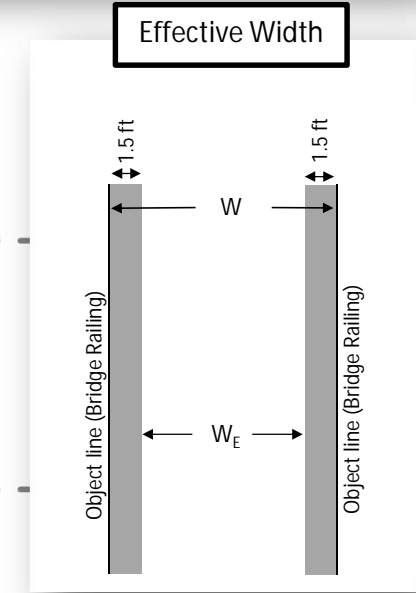

PEDESTRIAN VOLUME BY TIME OF DAY

3.1.5 Pedestrian Volume Level of Service

The 15-minute pedestrian volume data was paired with the field verified effective walkway widths and a LOS value calculated and assigned for every 15-minute data collection increment. The 2010 HCM LOS values are calculated as a numerical threshold based on effective walkway width (W_E); for example, a ten-foot effective walkway width ($W_E=10'$) operating at LOS A can accommodate up to 750 pedestrians in 15-minutes and the same walkway can accommodate up to 1,500 pedestrians with a LOS C. It is important to note that the LOS values change depending on the effective walkway width (W_E) provided.

Figure 3.4 through Figure 3.41 indicate the maximum 15-minute volume identified for both count dates (May 26, 2012 – Holiday Saturday and June 16, 2012 – Typical Saturday) at each count location. Also listed on each figure is the walkway width (W) and effective walkway width (W_E). The LOS threshold levels were calculated and are shown in the figures. A review of the summary figures shows that of the 38 count locations, eight count locations were found with pedestrian volumes on the Holiday Saturday that exceeded LOS C conditions with two of those locations providing LOS E. The locations shown in Table 3.4 experienced LOS D or worse during either the holiday Saturday or typical Saturday.

Table 3.4 – Pedestrian Volume Count Locations that Exceeded LOS C

Holiday Saturday - May 26, 2012			Typical Saturday - June 16, 2012		
Count Location	Figure	LOS	Count Location	Figure	LOS
Harley Dav.	Figure 3.16	E	Harley Dav.	Figure 3.16	E
Flam W Bridge	Figure 3.36	D	Harrah's	Figure 3.24	D
Flamingo	Figure 3.21	D	Venetian	Figure 3.26	E
Caesars Palace	Figure 3.22	D			
Forum Shops	Figure 3.23	D			
Harrah's	Figure 3.24	D			
Mirage	Figure 3.25	E			
Venetian	Figure 3.26	D			

It should be noted that the LOS calculations were prepared assuming the entire effective walkway width (W_E) was available for pedestrian traffic. In situations where a non-permanent obstruction could be in the walkway, the calculated effective walkway width (W_E) would be reduced and thus a potentially lower level of service would be provided.

As mentioned in the previous section, the LOS within the outer portion of the study corridor was observed to be acceptable, LOS C or better, during the entire data collection process, both for the holiday and typical Saturday. Generally, the inner portion of the study corridor functions at LOS D or better throughout the day with the exception of several specific walkway restriction areas including the walkways in front of Harley Davidson Cafe and in front of the Mirage Hotel/Casino, which provided LOS E for short durations between 8:30 PM and 12:30 AM.

To provide an overall summary of the pedestrian volume LOS values for the Resort Corridor, Figure 3.42 was created.

The following list of location was identified as constricted walkways or “pinch points” which could result in conditions of LOS less than C:

- East walkway across from Mandalay Bay Hotel/Casino
- Northeast quadrant of the intersection of Las Vegas Boulevard and Rue de Monte Carlo/MGM Drive
- East walkway directly south of Harmon Avenue, in front of the Harley Davidson Cafe
- West walkway south of the Bellagio Hotel/Casino
- East walkway at the north end of the Planet Hollywood Hotel/Casino (east-west crosswalk)
- East walkway in front of Margaritaville directly south of Caesars Palace Boulevard
- West walkway directly north of Caesars Palace Boulevard in front of the Coliseum
- East walkway in front of Harrah's Hotel/Casino at the east-west crosswalk
- West walkway north of the Mirage Hotel/Casino North driveway, south of Siren's Cove Boulevard

These locations are discussed and evaluated in Section 4.2.

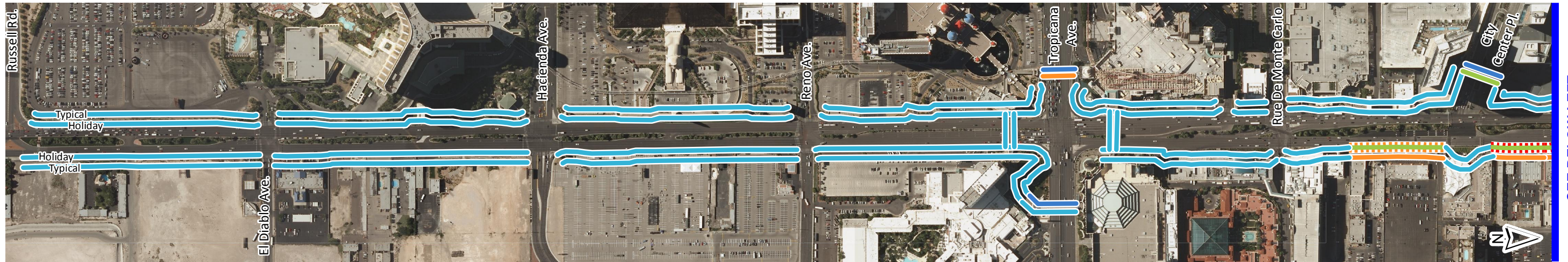

SEE BELOW LEFT

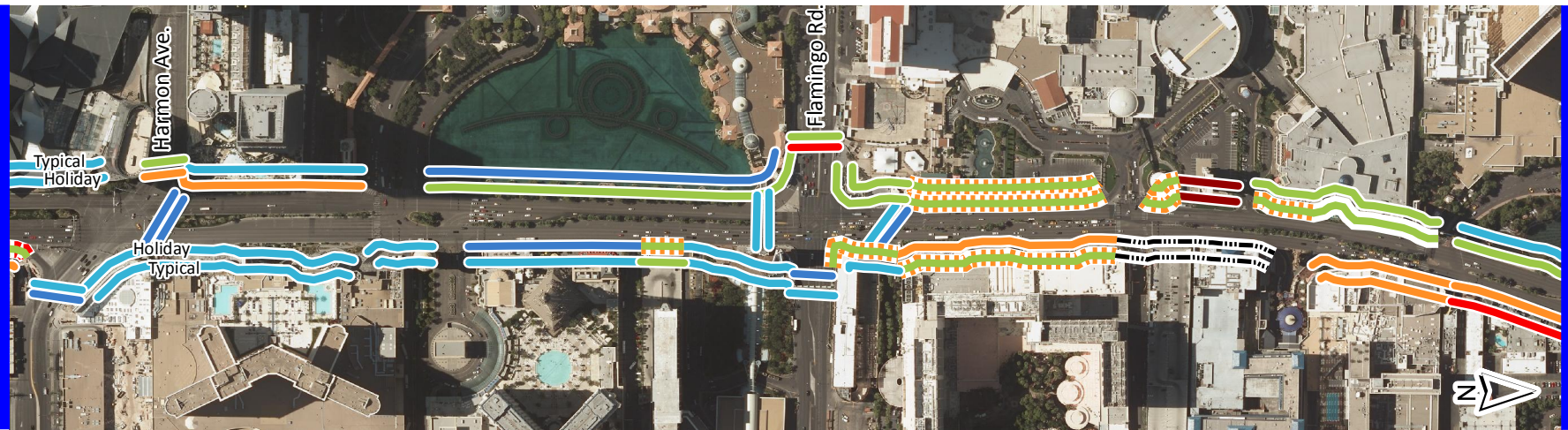

SEE ABOVE RIGHT

SEE RIGHT
SEE LEFT

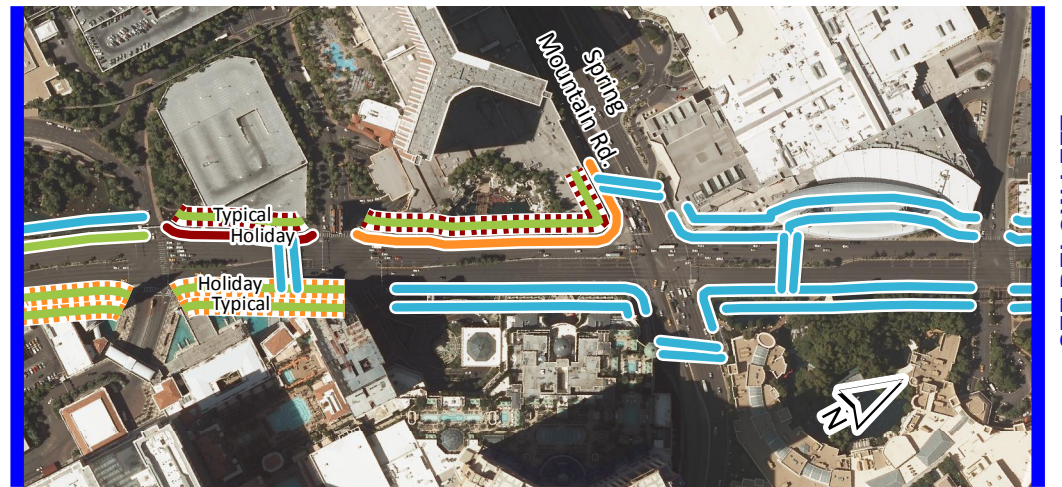

SEE BELOW LEFT

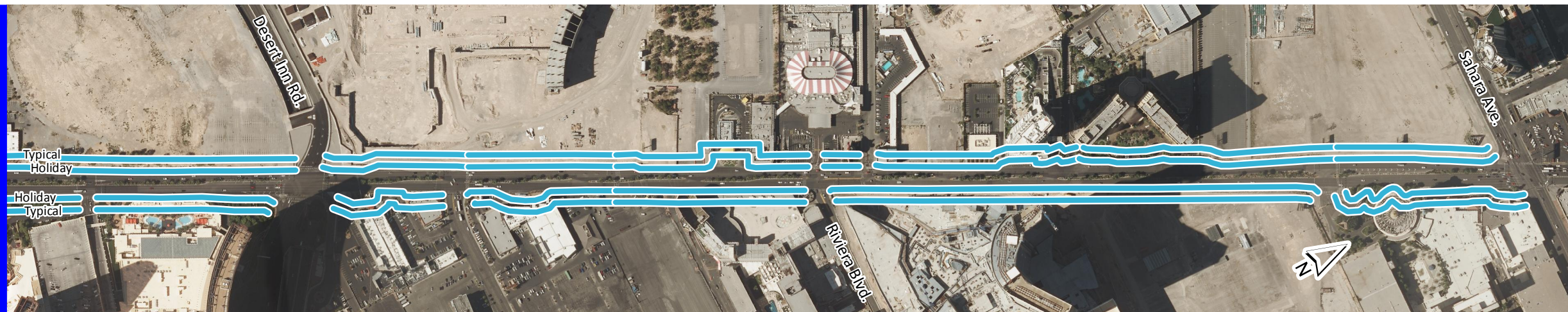

SEE ABOVE RIGHT

Legend

Level of Service (LOS)

- A
- B
- C to D*
- C to E*
- C to F*
- C
- D
- E
- F
- Under Construction

* C to "X" with 2.25 ft W_e reduction for an obstruction

**LEVEL OF SERVICE (LOS)
AVERAGE EFFECTIVE WALKWAY WIDTH (W_e) AND AVERAGE 15 MIN. VOLUME
9 P.M. - 11 P.M.**

FIGURE 3.42 78

3.2 Walking Speeds

Pedestrian walking speeds were recorded to provide an alternative level of service (LOS) assessment of the Las Vegas Boulevard pedestrian walkways within the Resort Corridor from Russell Road to Sahara Avenue. The study corridor was divided into walkway segments for evaluation. Twenty-five (25) individual segments were identified on the west side of Las Vegas Boulevard (labeled W1 – W25 from south to north) and twenty-eight (28) were established on the east side (labeled E1 – E28 from south to north). On Wednesday April, 25 2012, four individuals collected free-flow walking speeds within the study corridor from Russell Road to Sahara Avenue. The free-flow walking speed data was statistically evaluated using a t-test to determine the similarity in walking speeds for each segment and side of street. The evaluation determined a free-flow walking speed for the entire study corridor of 4.23 ft/sec with a 95% confidence level. Further analysis concluded that a statistical difference existed between certain segments of the study corridor. Strategic sectioning of Las Vegas Boulevard allowed for a more in depth walking speed analysis. Major cross streets were used to create four evaluation segments for the study corridor:

1. Russell Road to Tropicana Avenue
2. Tropicana Avenue to Flamingo Road
3. Flamingo Road to Spring Mountain Road
4. Spring Mountain Road to Sahara Avenue

The collected pedestrian volume data indicated that the outer two segments of the study corridor (1. Russell Road to Tropicana Avenue and 4. Spring Mountain Road to Sahara Avenue) have less pedestrian activity than the inner two segments. The outer two segments also have less existing development. The free-flow walking speed data was analyzed for the segment groupings of 1 and 4 as the outer portion of the study corridor and 2 and 3 as the inner portion. The walking speed data collected on April 25, 2012 identified a statistically different free-flow walking speed for the inner and outer study corridor segments at a 95% confidence level. Table 3.5 contains the free-flow walking speed summary.

Table 3.5 – Free-flow Walking Speeds

	Walking Speed (feet per second)	Level of Service (LOS)
Outer segments	4.40	A
Inner segments	3.87	D
All segments	4.23	B

There was no statistically significant difference at a 95% confidence level between the free-flow walking speeds for the west side and east sides of the outer or inner portions of the study corridor.

Walkway level of service (LOS) as described in Section 2.3.1 is based on pedestrian volumes and effective walkway widths (W_E) and is not related to the calculation of walkway LOS based upon walking speed. The 2010 HCM identifies walking speeds less than LOS C as undesirable. Table 3.6 summarizes the accepted walking speed values with their corresponding LOS

thresholds from the HCM 2010. As discussed in Section 1.4.1, the 2010 HCM walking speed LOS thresholds are based on individuals walking to work, going to class or walking in an airport and do not represent leisure walking speeds.

Table 3.6 – LOS and Average Speed Values

LOS	Average Speed (ft/s)	Comments
A	>4.25	Ability to move in desired path, no need to alter movements
B	>4.17 - 4.25	Occasional need to adjust path to avoid conflicts
C	>4.00 - 4.17	Frequent need to adjust path to avoid conflicts
D	>3.75 - 4.00	Speed and ability to pass slower pedestrians restricted
E	>2.50 - 3.75	Speed restricted, very limited ability to pass slower pedestrians
F	≤2.50	Speeds severely restricted, frequent contact with other users

The average free-flow walking speed was determined to be 3.87 feet per second for the inner portion of the study corridor from Tropicana Avenue to Spring Mountain Road. This walking speed is within the 2010 HCM range for LOS D. Since the observed free-flow walking speed is categorized as LOS D, the study concluded that a walking speed categorized as LOS D is acceptable for the Las Vegas Boulevard tourist environment.

A possible explanation for the lower acceptable walking speed along the “Strip” is a tourist leisure mentality. A tourist is less rushed and is focused on enjoying the experience as opposed to someone in an airport walking to a terminal or on a city street walking to an appointment.

Also of interest is the variation in free-flow walking speeds and congested walking speeds. Some of the high pedestrian volume walking speed segments during the 9:00 PM – 12:00 AM study period experienced higher average walking speeds than the 1:00 PM – 4:00 PM and 5:00 PM – 8:00 PM periods on Saturday, May 26, 2012 of Memorial Day weekend. The walking speed data collection agents observed the pedestrian stream accelerate after they were slowed at a “bottleneck”. Although more congestion was experienced in the 9:00 PM – 12:00 AM period, the total travel time did not significantly change due to this slow-down/speed-up effect. The average travel time for the length of the study corridor (from Russell Road to Sahara Avenue) was found to be one hour and 34 minutes.

The study corridor segment results from the free-flow walking speed study are included in Table 3.7 and Table 3.8 showing the average walking speed in each segment of the study corridor on the west and east side of Las Vegas Boulevard respectively. It is interesting to note that the overall average of the west side of the study corridor was found to be 4.25 ft/sec (LOS B) while the east side of the study corridor was found to be 4.00 ft/sec (LOS D). Upon reviewing the results, it is important to remember that the overall average walking speed took into account segment E15 on the east side

which was under construction during data collection. The minimum walking speed observed on the west side was 3.53 ft/sec (LOS E) in front of the Monte Carlo Hotel/Casino where walkway widths average 25 feet, further demonstrating that the HCM 2010 walking speed LOS D and E may be considered acceptable as a Las Vegas tourist walking speed.

Table 3.7 – Free-flow Walking Speed – West Segments

Number	Segment ID Name	Walking Speed (ft/sec) 9AM – 12PM
W1	Four Seasons	4.52
W2	Mandalay Bay	4.44
W3	Luxor	4.27
W4	Excalibur	4.38
W5	New York-New York	4.10
W6	Monte Carlo Parking	4.36
W7	Monte Carlo	3.53
W8	CityCenter	3.90
W9	Cosmopolitan	3.78
W10	Bellagio	3.85
W11	Caesars Palace	3.78
W12	Caesars Coliseum	3.74
W13	Forum Shops	4.35
W14	Mirage	4.21
W15	Mirage Parking	4.22
W16	Treasure Island	4.38
W17	Fashion Show Mall	4.25
W18	Plaza (Future)	4.74
W19	Echelon South	3.89
W20	Echelon North	4.48
W21	Slots A' Fun	4.43
W22	Circus Circus	4.87
W23	Sky Las Vegas	4.55
W24	Hilton Grand Vacations	4.63
W25	Sahara Corner (Vacant)	4.49
	Overall Average	4.25
	LOS	B

Table 3.8 – Free-flow Walking Speed – East Segments

Segment ID		Walking Speed (ft/sec)
Number	Name	9AM - 12PM
E1	Diamond Inn	4.59
E2	SkyVue (Future)	4.58
E3	Luxor Overflow Parking	4.45
E4	Tropicana	4.37
E5	MGM/Showcase	3.63
E6	Smith & Wollensky	4.22
E7	Polo Towers	3.79
E8	Travelodge	3.76
E9	Harley Davidson	3.12
E10	Planet Hollywood	4.00
E11	Paris South	2.92
E12	Paris North	3.77
E13	Bally's	3.94
E14	Flamingo	3.85
E15	Imperial Palace	3.49
E16	Harrah's	3.98
E17	Casino Royale	3.35
E18	Venetian South	4.08
E19	Venetian	3.55
E20	Palazzo	4.82
E21	Wynn	4.03
E22	Wynn Parking	4.02
E23	Encore	5.17
E24	Gold Key Shops	3.53
E25	Peppermill	4.23
E26	Riviera	4.31
E27	Fontainebleau	4.41
E28	SLS	4.12
Overall Average		4.00
Overall LOS		D

The minimum walking speed observed on the east side of the study corridor was 2.92 ft/sec (LOS E) in front of the Paris Hotel/Casino sign. The east side of the study corridor also showed that the free-flow walking speed in certain segments was observed to be LOS D and E, further supporting the acceptability of walking speed LOS lower than LOS C for the Las Vegas tourist.

Data included in Table 3.9 summarizes the holiday Saturday (May 26) average collected walking speeds for each walking segment on the west side of Las Vegas Boulevard between Russell Road and Sahara Avenue. It can be seen that while the 1:00 PM – 4:00 PM and 5:00 PM – 8:00 PM time periods maintained an average walking speed of 4.01 ft/sec (equivalent to a LOS C), the 9:00 PM – 12:00 AM time period average walking speed deteriorated to 3.79 ft/sec (LOS D). Review of the walking speeds on the individual segments show various segments that experience LOS D and LOS E throughout the day.

Table 3.9 – Average Walking Speed – West Segments – 5/26/2012 (Holiday Saturday)

Segment ID		Walking Speed (ft/sec)		
Number	Name	1PM – 4PM	5PM – 8PM	9PM – 12AM
W1	Four Seasons	4.56	4.49	4.52
W2	Mandalay Bay	4.41	4.40	3.94
W3	Luxor	4.22	4.32	4.17
W4	Excalibur	4.16	4.36	4.30
W5	New York-New York	4.13	3.78	3.65
W6	Monte Carlo Parking	3.85	3.73	3.00
W7	Monte Carlo	3.40	3.45	3.22
W8	CityCenter	3.89	3.94	3.61
W9	Cosmopolitan	3.46	3.66	3.26
W10	Bellagio	3.88	3.49	2.93
W11	Caesars Palace	3.65	3.57	3.16
W12	Caesars Coliseum	3.07	3.45	3.16
W13	Forum Shops	3.57	3.51	3.28
W14	Mirage	4.02	4.14	3.51
W15	Mirage Parking	3.64	3.78	2.84
W16	Treasure Island	4.32	4.15	3.72
W17	Fashion Show Mall	3.80	4.09	3.92
W18	Plaza (Future)	4.66	4.60	4.34
W19	Echelon South	3.90	3.93	3.80
W20	Echelon North	4.19	3.98	4.18
W21	Slots A' Fun	4.36	4.34	4.34
W22	Circus Circus	4.28	4.45	4.35
W23	Sky Las Vegas	4.35	4.42	4.50
W24	Hilton Grand Vacations	4.14	4.06	4.53
W25	Sahara Corner (Vacant)	4.37	4.24	4.53
Overall Average		4.01	4.01	3.79
Overall LOS		C	C	D

Table 3.10 shows the holiday Saturday (May 26) average walking speed for each walkway segment from Russell Road to Sahara Avenue on the east side of Las Vegas Boulevard. It is important to recognize that, like the west side, each value in this table is the average result of six individual walking speeds for each walking segment. Similar to the west side of the strip, the 9:00 PM – 12:00 AM time period, which time corresponds to the highest observed pedestrian volumes, was found to have a decrease in average walking speed for the study corridor including some segments that experienced LOS D, E and F. The evaluation also included segment E15 on the east side of the study corridor was under construction during data collection for the Caesars Linq project (significant decreases in walking speed were experienced in this area – see Picture 3.12).

Table 3.10 – Average Walking Speed – East Segments – 5/26/2012 (Holiday Saturday)

Segment ID		Walking Speed (ft/sec)		
Number	Name	1PM – 4PM	5PM – 8PM	9PM – 12AM
E1	Diamond Inn	4.71	4.89	4.51
E2	SkyVue (Future)	4.56	4.62	4.34
E3	Luxor Overflow Parking	4.46	4.57	4.24
E4	Tropicana	4.44	4.40	4.16
E5	MGM/Showcase	2.98	3.58	3.92
E6	Smith & Wollensky	3.31	3.72	3.04
E7	Polo Towers	3.36	3.24	3.19
E8	Travelodge	4.01	3.75	3.77
E9	Harley Davidson	2.30	2.76	2.49
E10	Planet Hollywood	3.41	3.37	3.43
E11	Paris South	2.45	2.37	2.54
E12	Paris North	3.17	3.13	3.34
E13	Bally's	3.30	3.25	2.78
E14	Flamingo	3.36	3.28	3.21
E15	Imperial Palace	2.52	2.95	1.56
E16	Harrah's	2.89	2.78	2.83
E17	Casino Royale	2.87	2.80	2.77
E18	Venetian South	3.00	3.45	3.55
E19	Venetian	3.25	3.53	3.25
E20	Palazzo	4.82	4.55	4.77
E21	Wynn	4.05	4.00	3.91
E22	Wynn Parking	4.05	3.91	4.02
E23	Encore	4.96	5.25	5.20
E24	Gold Key Shops	3.57	3.44	3.41
E25	Peppermill	3.92	4.05	4.14
E26	Riviera	4.54	4.07	4.10
E27	Fontainebleau	4.51	4.30	4.31
E28	SLS	4.21	4.30	4.10
Overall Average		3.68	3.73	3.60
Overall LOS		E	E	E

The results of the walking speed data from the June 16 data collection effort are summarized in Table 3.11 and Table 3.12 for the west and east sides of the study corridor respectively.

Table 3.11 – Average Walking Speed – West Segments – 6/16/2012
(Typical Saturday)

Segment ID		Walking Speed (ft/sec)		
Number	Name	1PM - 4PM	5PM - 8PM	9PM - 12AM
W1	Four Seasons	4.36	4.57	4.59
W2	Mandalay Bay	4.32	4.54	4.52
W3	Luxor	4.41	4.43	4.35
W4	Excalibur	4.23	4.38	4.22
W5	New York-New York	3.99	3.97	3.85
W6	Monte Carlo Parking	3.39	3.84	3.13
W7	Monte Carlo	3.55	3.55	3.37
W8	CityCenter	3.95	4.01	3.76
W9	Cosmopolitan	3.86	4.05	3.21
W10	Bellagio	3.90	4.02	2.95
W11	Caesars Palace	3.76	3.77	3.40
W12	Caesars Coliseum	3.59	3.94	3.27
W13	Forum Shops	3.74	3.89	3.45
W14	Mirage	4.01	4.26	3.54
W15	Mirage Parking	3.68	3.72	3.59
W16	Treasure Island	4.17	4.42	4.05
W17	Fashion Show Mall	4.08	4.25	4.21
W18	Plaza (Future)	4.58	4.73	4.48
W19	Echelon South	3.73	3.89	3.86
W20	Echelon North	3.96	4.13	3.80
W21	Slots A' Fun	4.12	4.53	4.21
W22	Circus Circus	4.17	4.06	4.13
W23	Sky Las Vegas	4.72	4.00	4.09
W24	Hilton Grand Vacations	4.20	4.88	4.60
W25	Sahara Corner (Vacant)	4.49	4.20	4.13
Overall Average		4.04	4.16	3.87

The overall average walking speeds of the study corridor were consistently higher for the typical Saturday than for the holiday Saturday. It is important to note that walking speeds of individual segments of LOS D and E were experienced on the typical Saturday and in one case a LOS F was observed (in front of the Paris Hotel/Casino sign during the 9:00 PM – 12:00 AM time period on the east side of Las Vegas Boulevard).

Table 3.12 – Average Walking Speed – East Segments – 6/16/2012
(Typical Saturday)

Segment ID		Walking Speed (ft/sec)		
Number	Name	1PM - 4PM	5PM - 8PM	9PM - 12AM
E1	Diamond Inn	4.66	4.61	4.55
E2	SkyVue (Future)	4.50	4.44	4.44
E3	Luxor Overflow Parking	4.38	4.44	4.23
E4	Tropicana	4.38	4.30	4.48
E5	MGM/Showcase	3.78	3.93	3.34
E6	Smith & Wollensky	3.77	3.77	3.24
E7	Polo Towers	3.91	3.72	3.56
E8	Travelodge	3.80	4.05	3.14
E9	Harley Davidson	2.92	3.20	2.60
E10	Planet Hollywood	3.80	3.73	3.30
E11	Paris South	3.24	3.14	2.16
E12	Paris North	3.73	3.79	3.14
E13	Bally's	3.80	3.75	3.03
E14	Flamingo	3.62	3.83	3.28
E15	Imperial Palace	3.50	3.31	2.99
E16	Harrah's	3.44	3.37	2.78
E17	Casino Royale	3.61	3.55	2.91
E18	Venetian South	3.94	3.76	3.40
E19	Venetian	3.68	3.59	3.30
E20	Palazzo	4.95	4.77	4.62
E21	Wynn	4.57	4.14	3.99
E22	Wynn Parking	4.45	4.20	4.00
E23	Encore	5.51	5.52	5.34
E24	Gold Key Shops	3.50	3.70	3.46
E25	Peppermill	4.23	4.30	4.36
E26	Riviera	4.35	4.39	4.20
E27	Fontainebleau	4.49	4.46	4.47
E28	SLS	4.29	4.40	4.51
Overall Average		4.03	4.01	3.67

(1:00 PM – 4:00 PM, 5:00 PM – 8:00 PM and 9:00 PM - 12:00 AM) for both data collection dates.

Upon commencement of the pedestrian study, it was hoped that conducting a free-flow and congested walking speed level of service (LOS) evaluation would aid in identifying possible congestion areas within the study corridor. The walking speed studies were useful in understanding tourist leisure walking speeds and the walking dynamics of Las Vegas Boulevard. However, the walking speed LOS, where LOS D and E may be considered unacceptable per the 2010 HCM procedures were typical free-flow walking speed on the "Strip" and were not found to be as effective in determining walkway congestion levels as the pedestrian volume LOS evaluation procedures of the 2010 HCM.

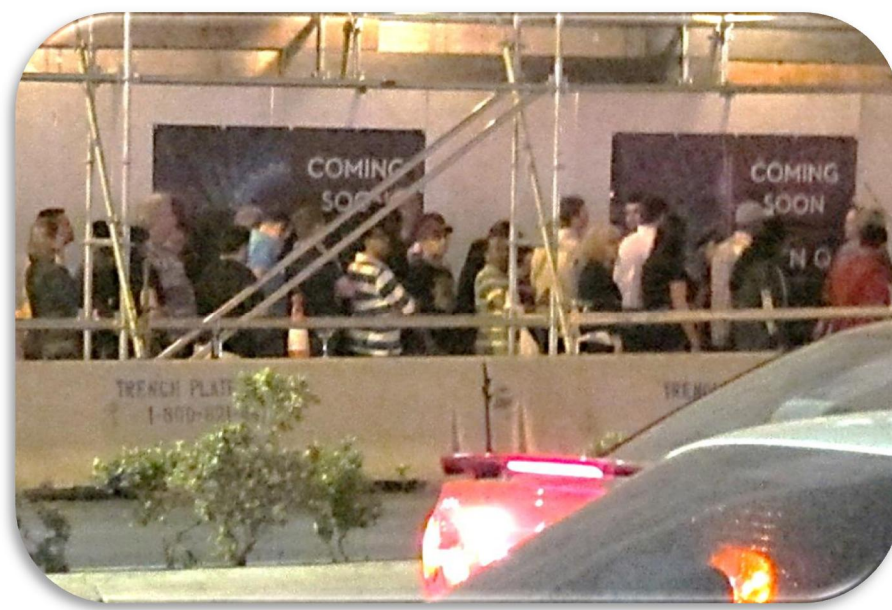

Picture 3.12 – Caesars Linq Construction Zone which Experienced Walking Speed LOS F.

The walking speed data is summarized for comparison in Figure 3.43 through Figure 3.46 which display the average observed pedestrian walking speed per segment on each side of Las Vegas Boulevard for both the holiday Saturday and a typical Saturday. The 2010 HCM walking speed ranges have been included in the figures for reference (note that for many segments of the inner portion of the study corridor, the free-flow walking speed LOS is LOS D or E). Again, it should also be noted that segment E15, the walkway in front of the Imperial Palace Hotel/Casino, was under construction for the Caesars Linq project and was significantly congested during portions of the data collection period.

Figure 3.47 through Figure 3.48 visually illustrate the average observed walking speed per segment for each of the data collection time periods

East Strip Observed Walking Speeds Holiday Saturday 5/26/2012

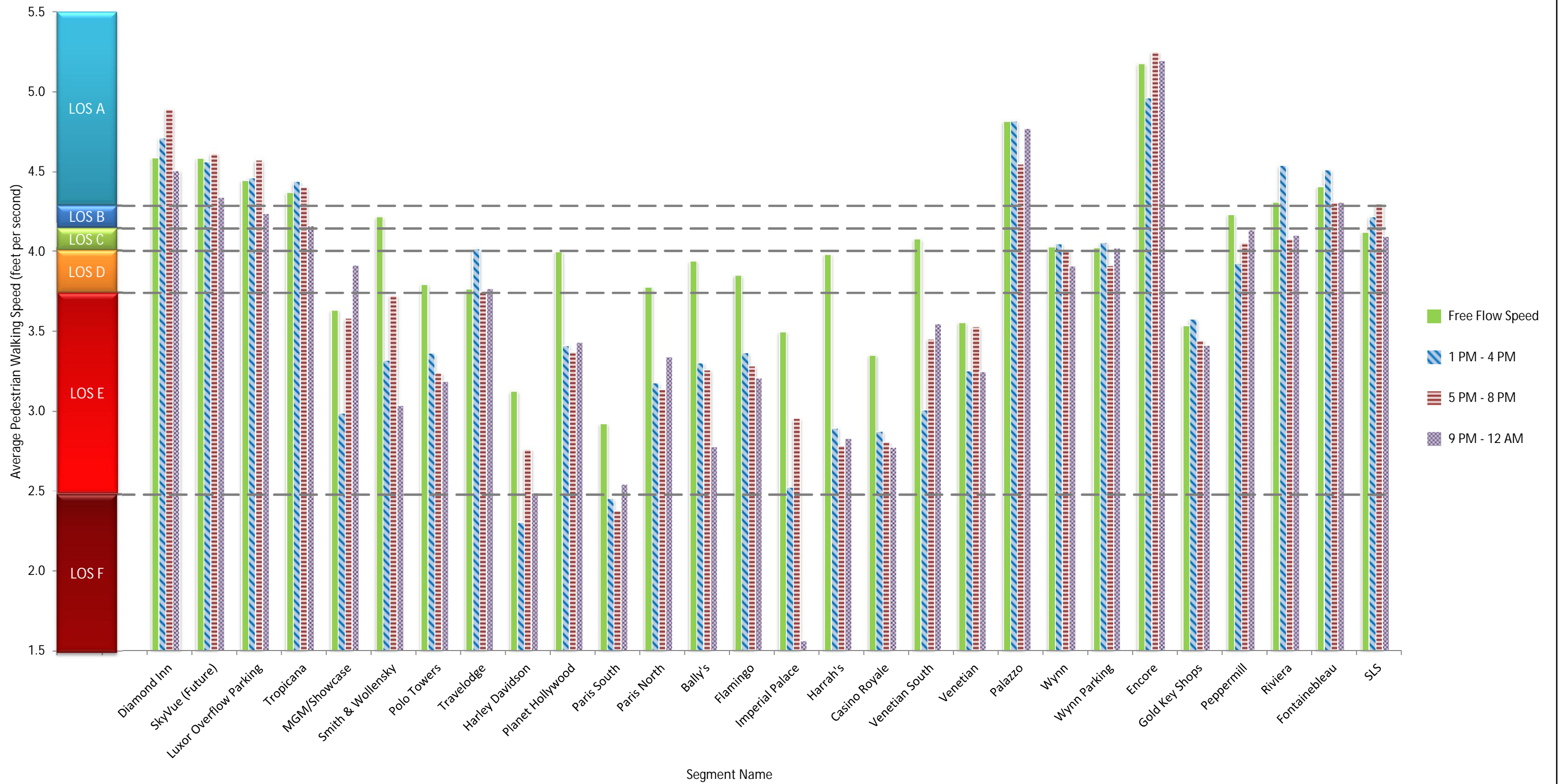

WALKING SPEED BY SEGMENT

West Strip Observed Walking Speeds Holiday Saturday 5/26/2012

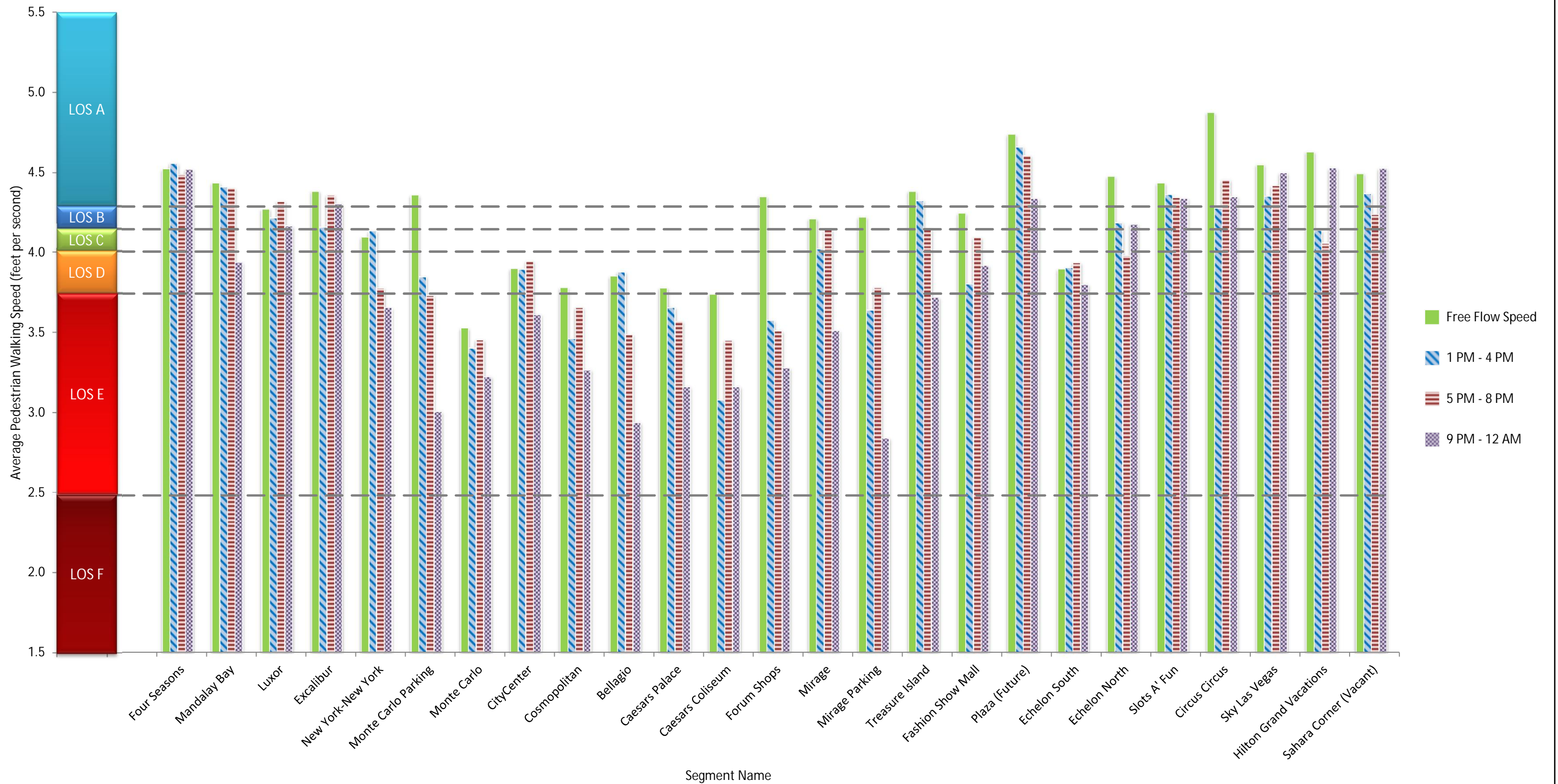

WALKING SPEED BY SEGMENT

East Strip Observed Walking Speeds Typical Saturday 6/16/2012

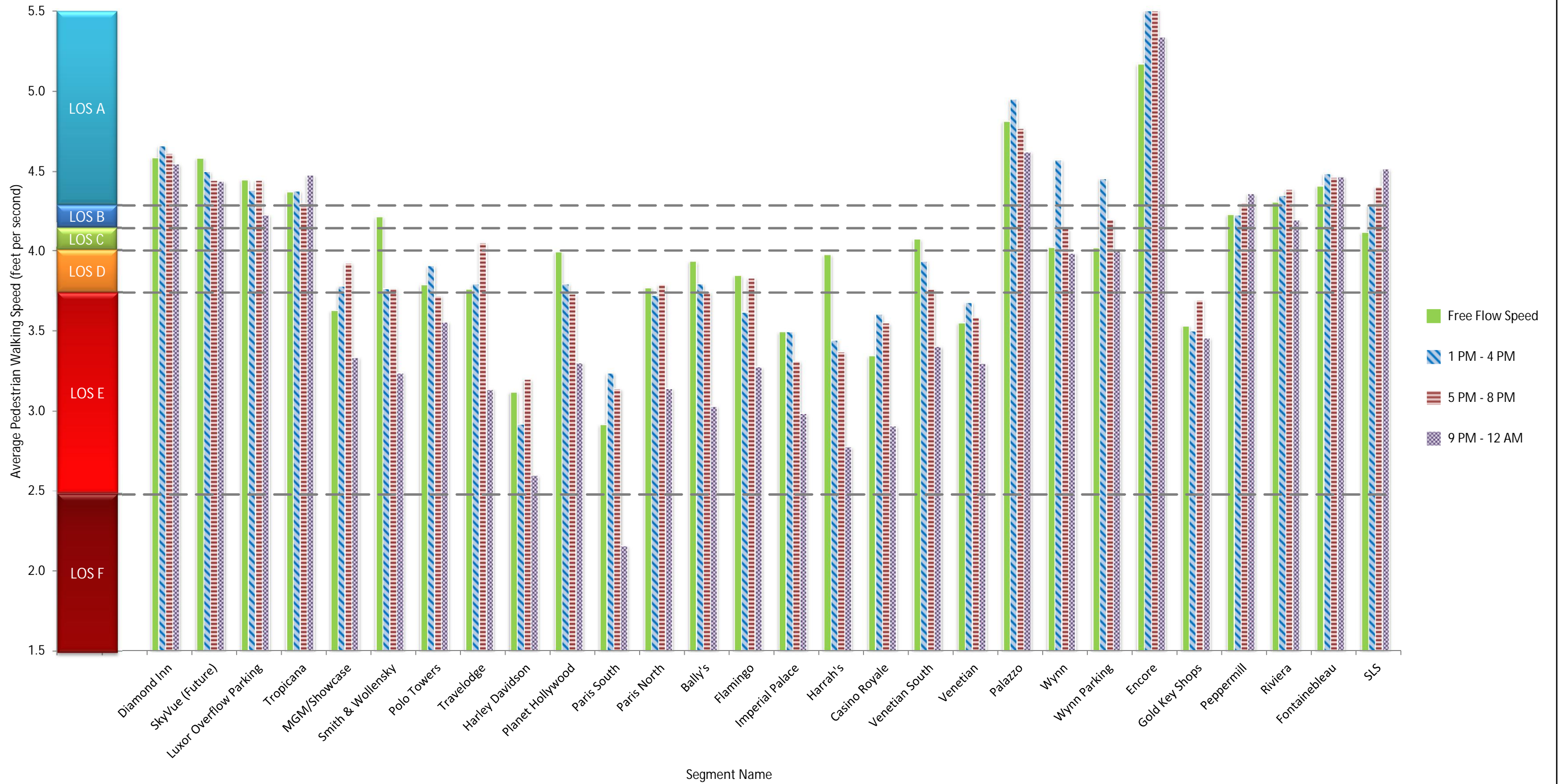

WALKING SPEED BY SEGMENT

West Strip Observed Walking Speeds Typical Saturday 6/16/2012

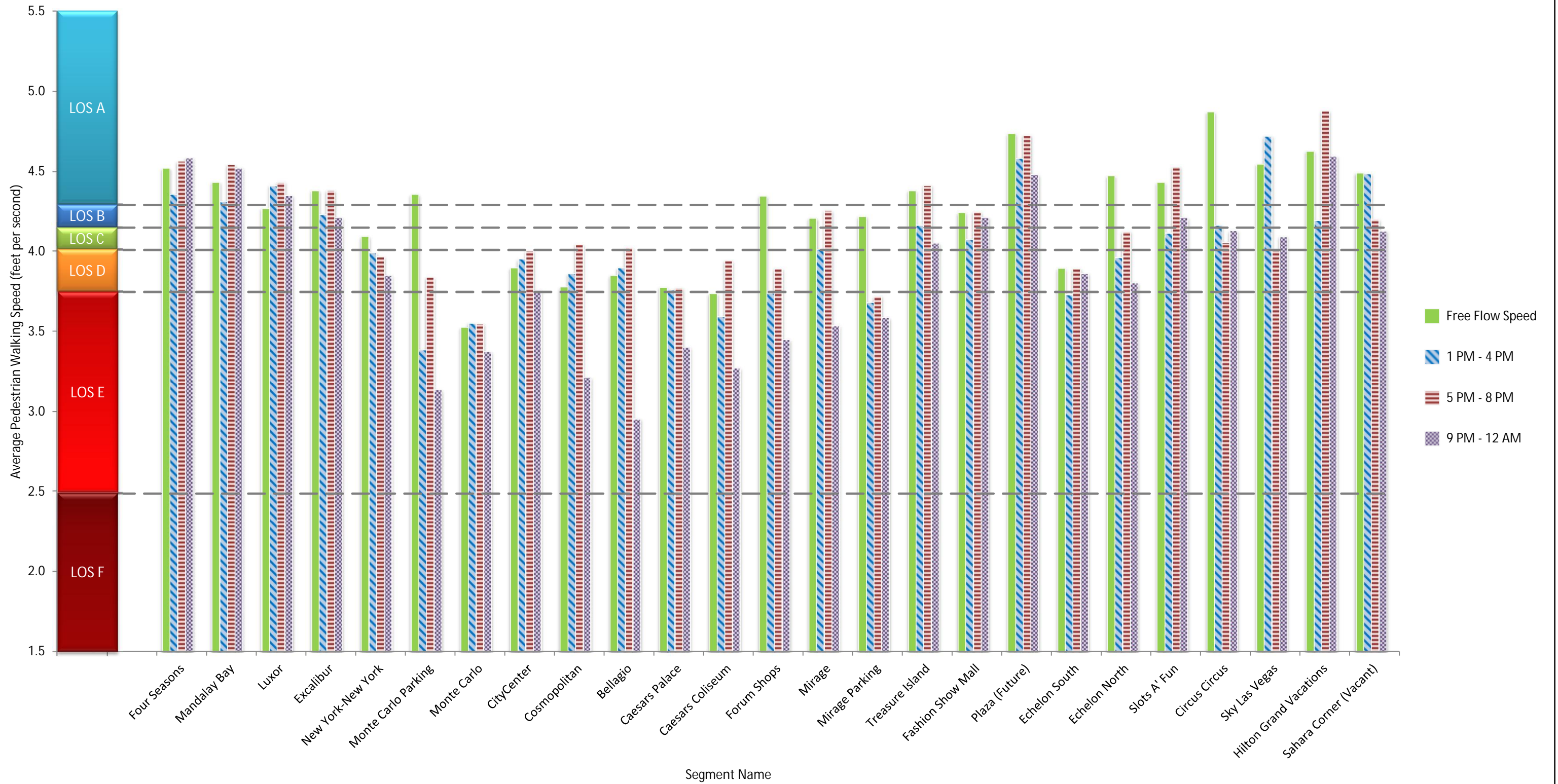

WALKING SPEED BY SEGMENT

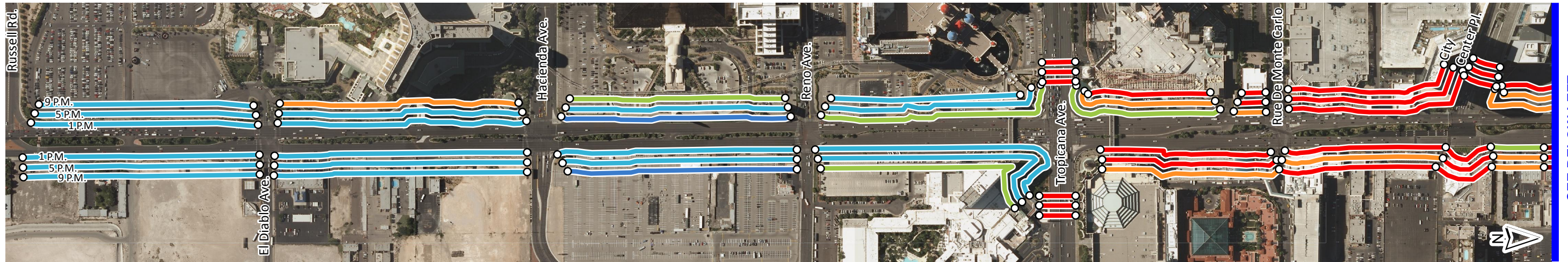

SEE BELOW LEFT

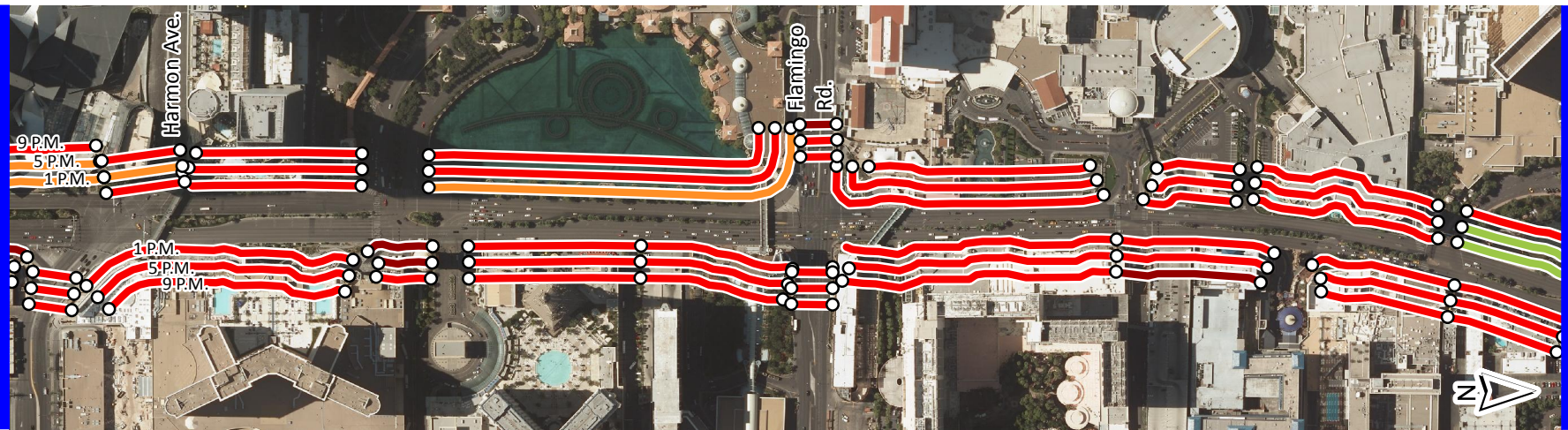

SEE ABOVE RIGHT

SEE RIGHT

SEE LEFT

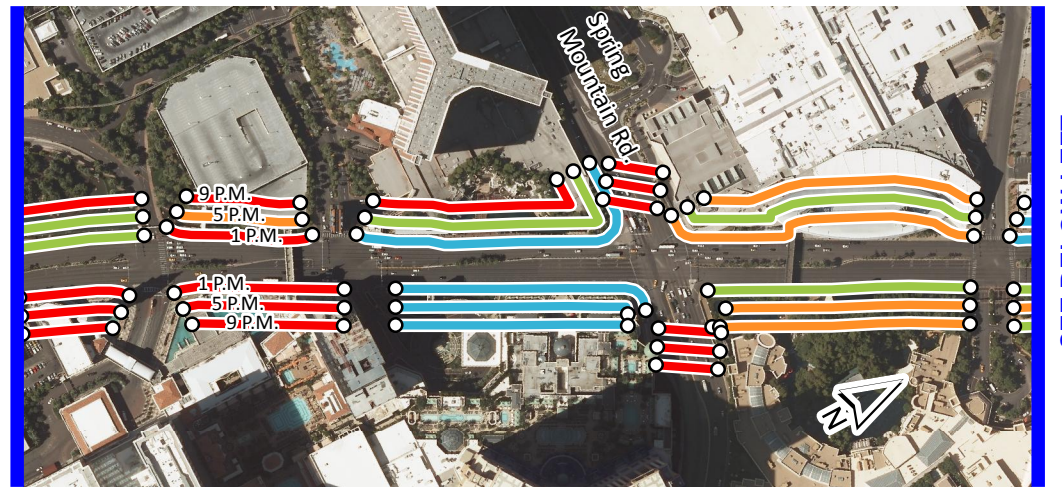

SEE BELOW LEFT

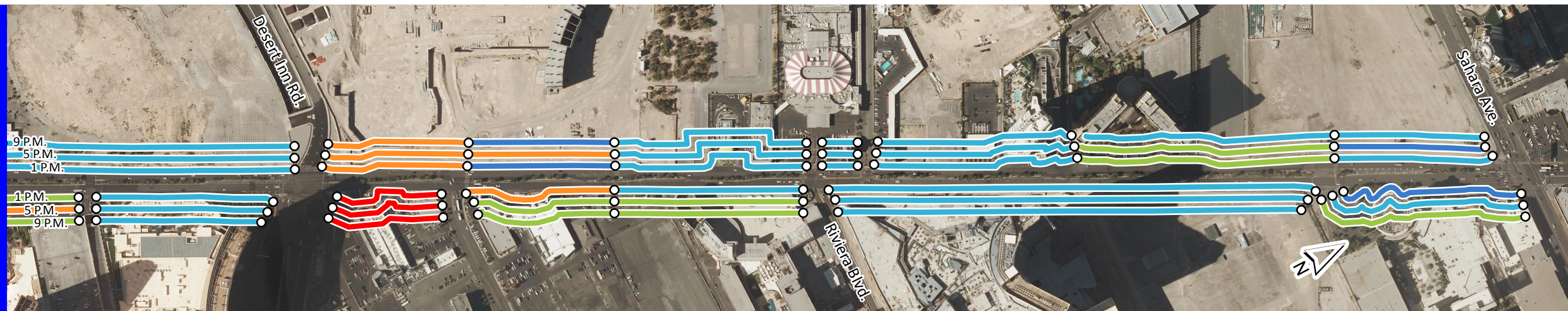

SEE ABOVE RIGHT

Legend

- Average Walking Speed (Ft./Sec.)**
- Greater than 4.25: LOS A
 - 4.18 - 4.25: LOS B
 - 4.01 - 4.17: LOS C
 - 3.76 - 4.00: LOS D
 - 2.51 - 3.75: LOS E
 - 2.50 or less: LOS F
 - Segment Limits

**AVERAGE PEDESTRIAN WALKING SPEED PER SEGMENT
SATURDAY MAY 26, 2012**

FIGURE 3.47 86

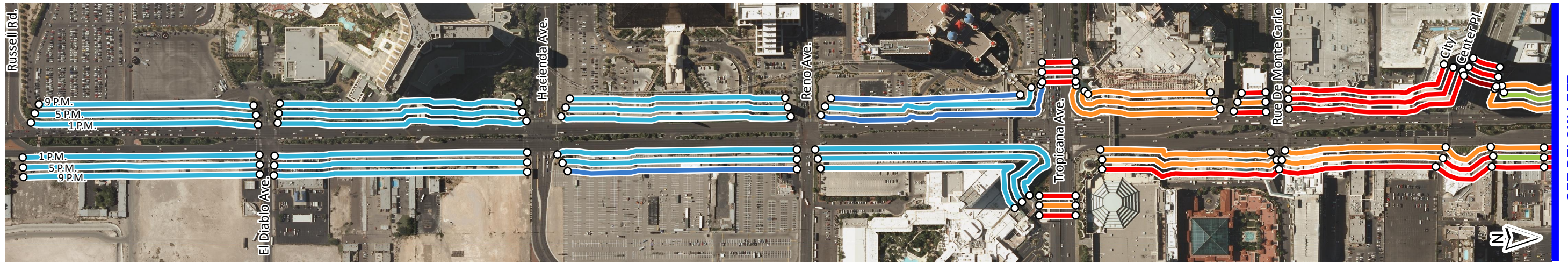

SEE BELOW LEFT

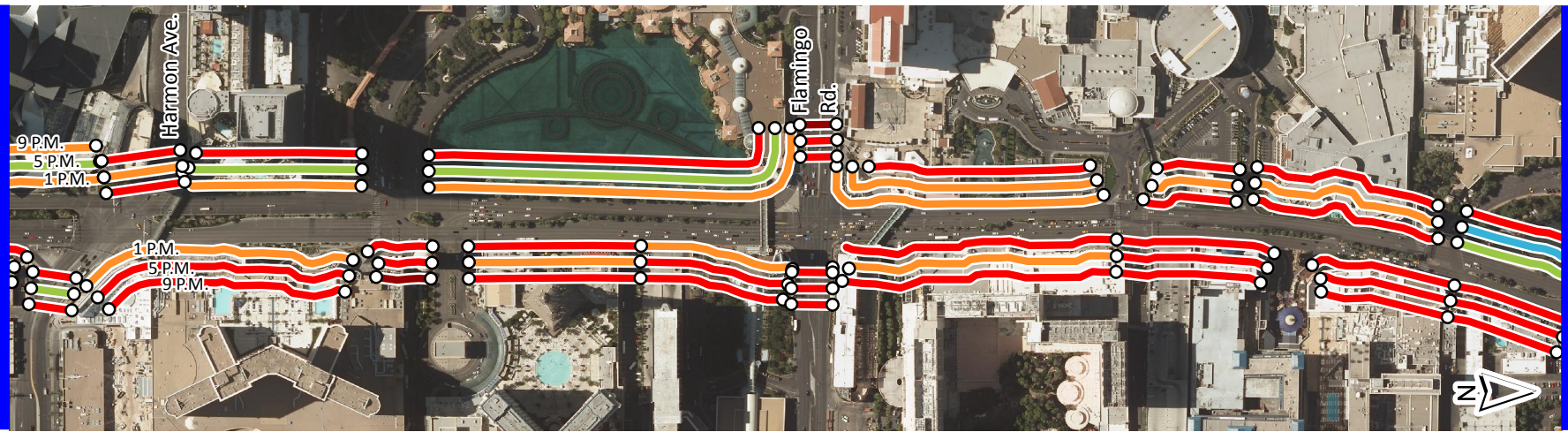

SEE ABOVE RIGHT

SEE RIGHT

SEE LEFT

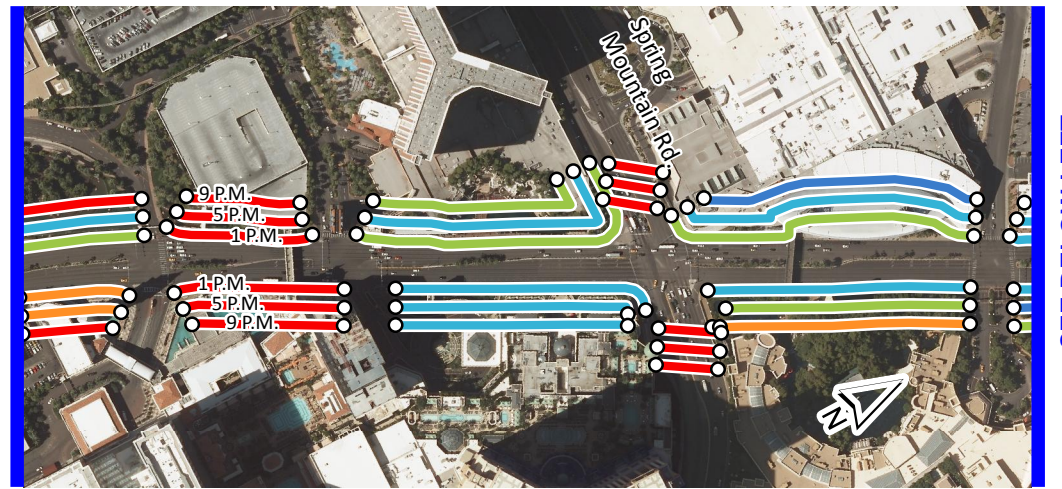

SEE BELOW LEFT

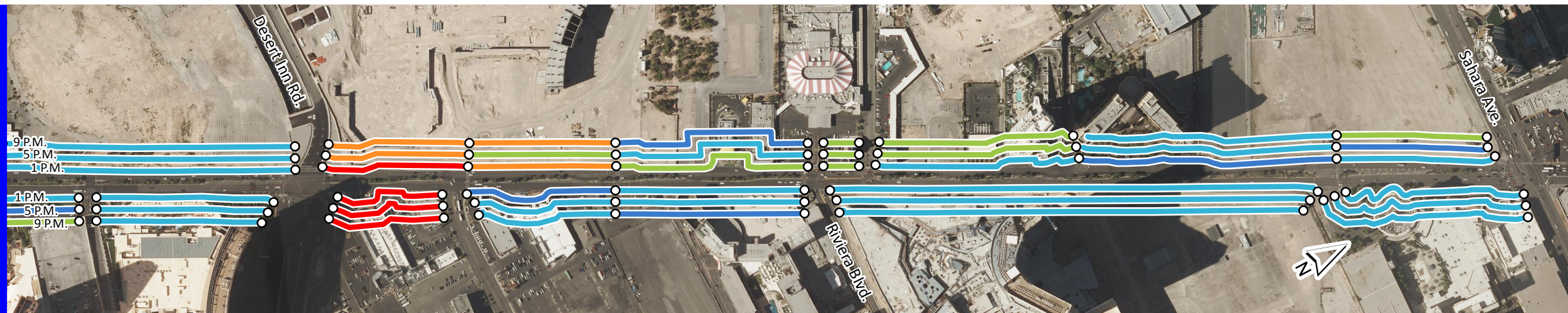

SEE ABOVE RIGHT

Legend

- Average Walking Speed (Ft./Sec.)**
- Greater than 4.25: LOS A
 - 4.18 - 4.25: LOS B
 - 4.01 - 4.17: LOS C
 - 3.76 - 4.00: LOS D
 - 2.51 - 3.75: LOS E
 - 2.50 or less: LOS F
 - Segment Limits

**AVERAGE PEDESTRIAN WALKING SPEED PER SEGMENT
SATURDAY JUNE 16, 2012**

FIGURE 3.48 87

3.2.1 Walking Speeds on Pedestrian Bridges

A separate data evaluation was conducted on the north/south Resort Corridor pedestrian bridges to determine walking speeds. The free-flow walking speeds of the bridges were observed to be lower than those of the Las Vegas Boulevard walkways, averaging 3.50 feet per second (2010 HCM walking speed LOS E) as compared to the inner “Strip” walkway speeds of 3.87 feet per second (LOS D). The observed pedestrian bridge average free-flow walk speed of 3.50 ft/sec is consistent with the 3.50 ft/sec the 2009 Manual on Uniform Traffic Control Devices (MUTCD) recommends for pedestrian walking speed to cross a street or highway. Figure 3.49 and Figure 3.50 compare the observed walking speeds for each of the two data collection dates.

These figures also show that the free-flow walking speed on eight of the nine north/south pedestrian bridges would be considered lower than LOS C per the 2010 HCM walking speed methodology. Even though the pedestrian volumes associated with some of the pedestrian bridges were significant, the walking speeds only slightly deteriorated. In some cases, average walking speeds increased from the free-flow walking speed; however, in the case of the Flamingo Road west pedestrian bridge, it was observed to have a walking speed with LOS F conditions during the 9:00 PM – 12:00 AM time period on both the holiday and typical Saturday.

Picture 3.13 and Picture 3.14 show pedestrian activity on various pedestrian bridges during the Memorial Day holiday Saturday (5/26/2012).



Picture 3.13 – Typical Pedestrian Bridge.

The walking speed data collection resulted in average walking speeds for each of the north/south pedestrian bridges in the study corridor, between Russell Road and Sahara Avenue. Table 3.13 and Table 3.14 show the free-flow walking speeds on the pedestrian bridges. It is interesting to note that the average LOS of the pedestrian bridges is within the LOS E range

according to the 2010 HCM walking speed LOS procedures on both the east and west side of the study corridor.



Picture 3.14 – Flamingo Road West Pedestrian Bridge.

Table 3.13 – Free-flow Walking Speed – West Pedestrian Bridges

Segment ID		Walking Speed (ft/sec)
Number	Name	9AM - 12PM
W3	Tropicana West	4.14
W5	City Center	3.46
W7	Harmon West	3.99
W11	Flamingo West	3.17
W14	Spring Mtn West	3.65
Overall Average		3.68
Overall LOS		E

Table 3.14 – Free-flow Walking Speed – East Pedestrian Bridges

Segment ID		Walking Speed (ft/sec)
Number	Name	9AM - 12PM
E4	Tropicana East	3.10
E8	Harmon East	2.92
E12	Flamingo East	3.80
E15	Spring Mtn East	3.26
Overall Average		3.27
Overall LOS		E

The free-flow walking speeds of LOS E on the pedestrian bridges indicate that the 2010 HCM walking speed LOS categories may not be suited for leisure walking speeds, while suggesting that the observed LOS may be acceptable to the Las Vegas tourist. Table 3.15 through Table 3.18 show the data collected throughout the study corridor for the holiday and typical Saturday (May 26 and June 16, 2012 respectively).

Table 3.15 – Average Walking Speed – West Pedestrian Bridges – 5/26/2012 (Holiday Saturday)

Segment ID		Walking Speed (ft/sec)		
Number	Name	1PM – 4PM	5PM – 8PM	9PM – 12AM
W3	Tropicana West	3.15	3.69	2.98
W5	City Center	3.52	3.52	3.09
W7	Harmon West	3.44	3.78	3.31
W11	Flamingo West	2.67	2.82	2.34
W14	Spring Mtn West	3.44	3.64	3.10
Overall Average		3.24	3.49	2.97
Overall LOS		E	E	E

Table 3.16 – Average Walking Speed – East Pedestrian Bridges – 5/26/2012 (Holiday Saturday)

Segment ID		Walking Speed (ft/sec)		
Number	Name	1PM – 4PM	5PM – 8PM	9PM – 12AM
E4	Tropicana East	3.02	3.57	2.88
E8	Harmon East	3.39	3.42	3.58
E12	Flamingo East	3.26	3.42	3.19
E15	Spring Mtn East	3.24	3.17	3.20
Overall Average		3.23	3.39	3.21
Overall LOS		E	E	E

Table 3.17 – Average Walking Speed – West Pedestrian Bridges – 6/16/2012 (Typical Saturday)

Segment ID		Walking Speed (ft/sec)		
Number	Name	1PM - 4PM	5PM - 8PM	9PM - 12AM
W3	Tropicana West	3.59	3.72	3.23
W5	City Center	3.45	3.52	3.14
W7	Harmon West	3.66	3.90	3.17
W11	Flamingo West	2.55	2.82	2.21
W14	Spring Mtn West	3.50	3.39	3.37
Overall Average		3.35	3.47	3.02
Overall LOS		E	E	E

Table 3.18 – Average Walking Speed – East Pedestrian Bridges – 6/16/2012 (Typical Saturday)

Segment ID		Walking Speed (ft/sec)		
Number	Name	1PM – 4PM	5PM – 8PM	9PM – 12AM
E4	Tropicana East	3.61	3.87	3.51
E8	Harmon East	3.57	4.10	3.33
E12	Flamingo East	2.82	3.69	2.90
E15	Spring Mtn East	3.44	3.27	3.13
Overall Average		3.36	3.73	3.22
Overall LOS		E	E	E

Similar to the walking speed LOS results, the pedestrian bridge walking speed LOS is not considered to be as effective in determining walkway congestion levels as the pedestrian volume LOS evaluation procedures of the 2010 HCM.

Observed Pedestrian Bridge Walking Speeds Holiday Saturday 5/26/2012

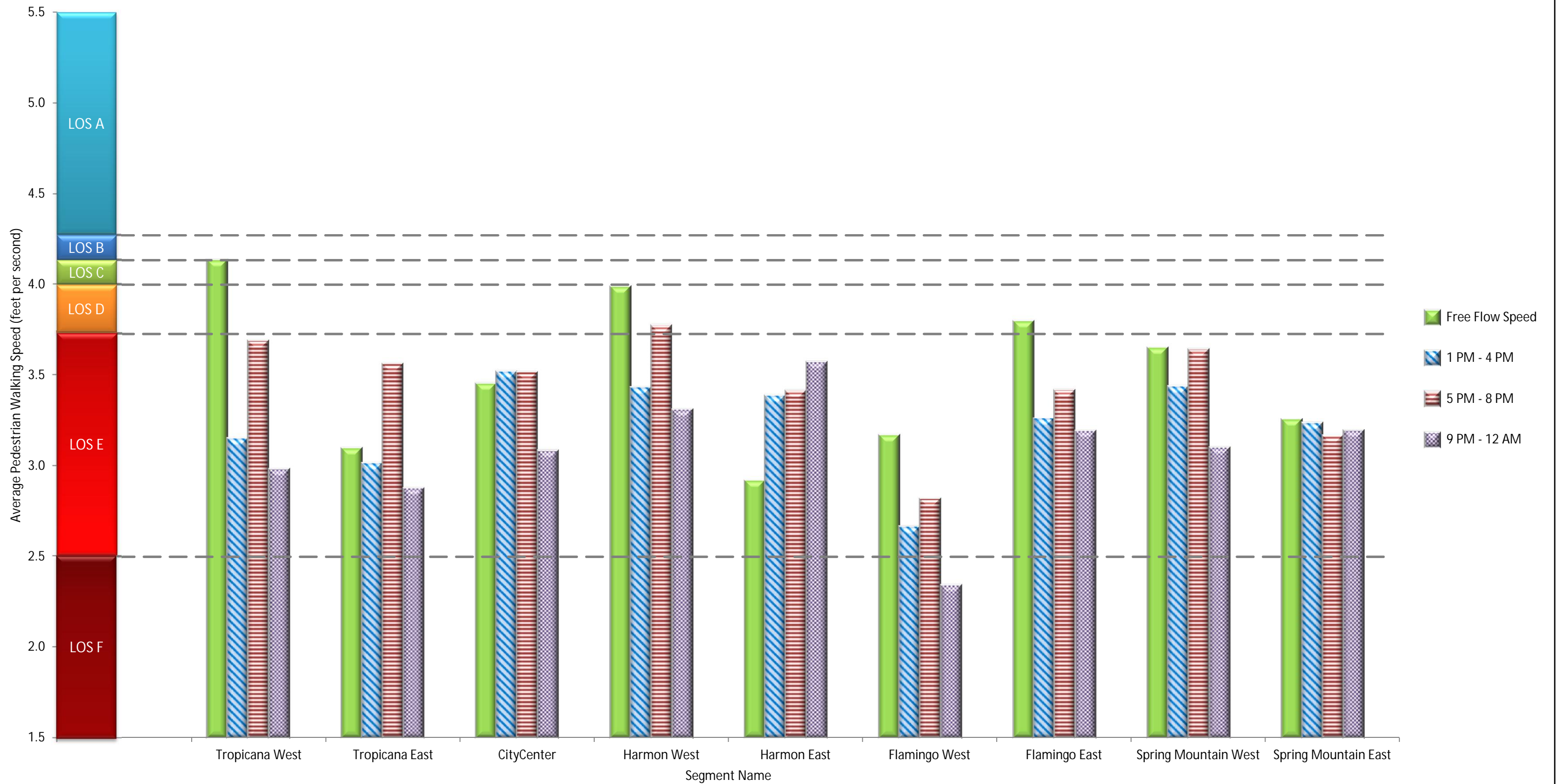

WALKING SPEED BY PEDESTRIAN BRIDGE

Observed Pedestrian Bridge Walking Speeds Typical Saturday 6/16/2012

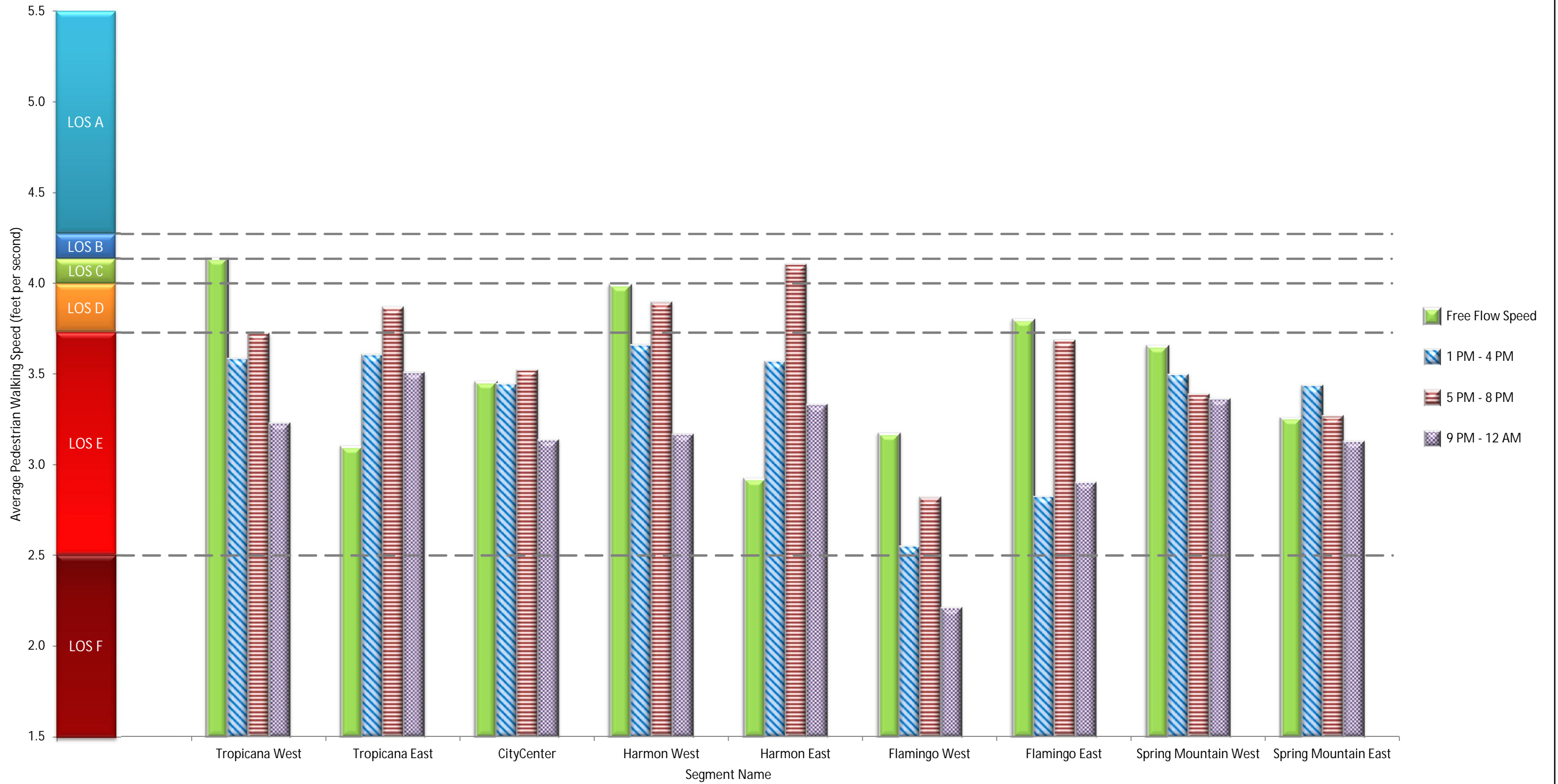

WALKING SPEED BY PEDESTRIAN BRIDGE

3.3 Non-Permanent Obstructions

The quantity, location and classification of non-permanent obstructions as gathered by field agents was compiled and analyzed to evaluate the effect of non-permanent obstructions on pedestrian LOS within the study corridor. The observations were conducted during the walking speed study. Individuals that were identified as non-permanent obstructions were recorded during three time period (1:00 PM – 4:00 PM, 5:00 PM – 8:00 PM and 9:00 PM – 12:00 AM) on May 26, 2012 and June 16, 2012.

Again, it is important to note that during the data collection process, the field agents were not instructed to determine if each “non-permanent obstruction” as counted was actually an obstruction to pedestrian flow. All non-permanent obstructions documented were considered as possible obstructions.

To provide an overall understanding of the dynamics of non-permanent obstructions within the Resort Corridor throughout the day, Figure 3.51 and Figure 3.52 were created with GIS representing the observed number of non-permanent obstructions per segment for each of the observation periods (1:00 PM – 4:00 PM, 5:00 PM – 8:00 PM and 9:00 PM – 12:00 AM) both for the holiday and typical Saturday. The following sections detail the data collected with regard to non-permanent obstructions both on walkways and on pedestrian bridges.

3.3.1 Non-Permanent Obstructions on Walkways

Table 3.19 provides a count summary for the average number of non-permanent obstructions observed for each side of Las Vegas Boulevard from Russell Road to Sahara Avenue during the holiday Saturday data collection effort.

Table 3.19 – Observed Non-Permanent Obstructions (May 26, 2012)

Time Period	West Side	East Side	TOTAL
1 PM - 4 PM	65	104	169
5 PM - 8 PM	103	156	259
9 PM - 12 PM	92	133	224

The highest number of non-permanent obstructions were observed on Saturday, May 26, 2012 between 5:00 PM and 8:00 PM, totaling 259 individuals either hand billing, performing, soliciting or vending. Table 3.20 summarizes the non-permanent obstructions observed on Saturday, June 16, 2012.

Table 3.20 – Observed Non-Permanent Obstructions (June 16, 2012)

Time Period	West Side	East Side	TOTAL
1 PM - 4 PM	51	88	139
5 PM - 8 PM	80	145	225
9 PM - 12 PM	103	149	252

The non-holiday Saturday (June 16, 2012) experienced a decrease in the total number of non-permanent obstructions in both the 1:00 PM – 4:00 PM and 5:00 PM – 8:00 PM time periods, but an increase in the 9:00 PM – 12:00 AM time period. The highest number of non-permanent obstructions observed on Saturday, June 16 was 252, only a slight decrease from the 259 observed on the holiday weekend Saturday of May 26.

The field notes taken by the walking agents for the highest observed time periods for each Saturday count were used to quantify the location of the observed non-permanent obstructions. The non-permanent obstructions were reviewed for walkway locations identified in Clark County Code Chapter 16.11. These locations are where non-permanent obstructions are not permitted to obstruct including: within 50 feet of a signalized intersection, access drive or mid-block cross walk. Categories were also created grouping non-permanent obstructions that were observed on pedestrian bridges, within 15 feet of pedestrian bridge landings and within 15 feet of a bus shelter. Table 3.21 and Table 3.22 summarize the distribution of the non-permanent obstructions within the study corridor on the holiday and typical Saturday (May 26 and June 16, 2012).

It can be seen in Table 3.21 that 140 or 54% on Saturday, May 26 and 146 or 58% on Saturday, June 16 of the observed non-permanent obstructions were located within areas where non-permanent obstructions are not permitted to obstruct under County Code 16.11. The majority of these non-permanent obstructions were classified as hand billers.

Further analysis showed that the majority of the non-permanent obstructions were located within the inner portion of the study corridor. A total of 98.5% of the individuals hand billing, performing, soliciting or vending were observed between Tropicana Avenue and Spring Mountain Road. Table 3.23 shows the percent distribution in relation to the inner and outer portions of the study corridor and also the east and west sides of Las Vegas Boulevard.

Table 3.23 – Non-Permanent Obstructions by Percentage 5PM – 8PM (May 26, 2012)

	West	East	Total
Outer	1.2%	0.3%	1.5%
Inner	38.6%	59.9%	98.5%
Total	39.8%	60.2%	100.0%

Table 3.21 – Distribution of Non-Permanent Obstructions 5PM – 8PM (May 26, 2012)

Non-Permanent Obstruction Category	Within 50' of an intersection, driveway or crosswalk	On pedestrian bridges	Within 15' of a pedestrian bridge landing	Within 15' of a bus stop	Other	TOTAL
Hand biller	110 (42%)	4 (2%)	3 (1%)	9 (3%)	27 (10%)	154 (59%)
Performer	21 (8%)	9 (3%)	1 (1%)	1 (1%)	43 (17%)	75 (29%)
Solicitor	4 (2%)	7 (3%)	1 (1%)	-	4 (2%)	16 (6%)
Vendor	5 (2%)	4 (2%)	-	-	6 (2%)	15 (6%)
Total	140 (54%)	24 (9%)	5 (2%)	10 (4%)	80 (31%)	259 (100%)

Table 3.22 – Distribution of Non-Permanent Obstructions 5PM – 8PM (June 16, 2012)

Non-Permanent Obstruction Category	Within 50' of an intersection, driveway or crosswalk	On pedestrian bridges	Within 15' of a pedestrian bridge landing	Within 15' of a bus stop	Other	TOTAL
Hand biller	113 (45%)	2 (1%)	4 (2%)	2 (1%)	24 (10%)	145 (58%)
Performer	22 (9%)	5 (2%)	3 (1%)	2 (1%)	38 (15%)	70 (28%)
Solicitor	6 (2%)	7 (3%)	-	-	4 (2%)	17 (7%)
Vendor	5 (2%)	6 (2%)	-	-	10 (4%)	21 (8%)
Total	146 (58%)	20 (8%)	7 (3%)	4 (2%)	76 (30%)	252 (100%)

Similarly, Table 3.24 shows the percent distribution of non-permanent obstructions on the non-holiday Saturday.

Table 3.24 – Non-Permanent Obstructions by Percentage 9PM – 12AM (June 16, 2012)

	West	East	Total
Outer	0.7%	0.5%	1.2%
Inner	40.2%	58.6%	98.8%
Total	40.9%	59.1%	100.0%

In comparing Table 3.23 and Table 3.24, it can be seen that the distribution of the non-permanent obstructions is similar on a holiday Saturday and a typical Saturday.

The non-permanent obstructions were quantified within each of the 53 study corridor segments (25 west segments and 28 east segments) and are graphically shown in Figure 3.53 and Figure 3.54 for the holiday Saturday on each side of Las Vegas Boulevard and Figure 3.55 and Figure 3.56 for the typical Saturday observations.

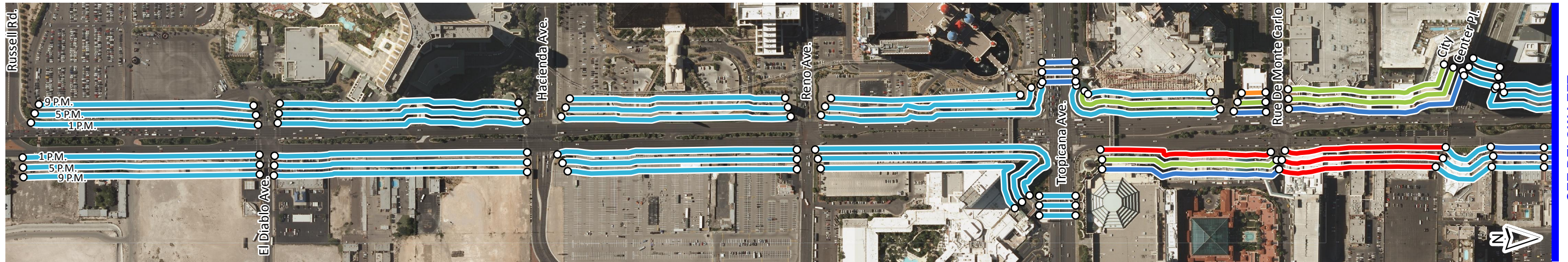

SEE BELOW LEFT

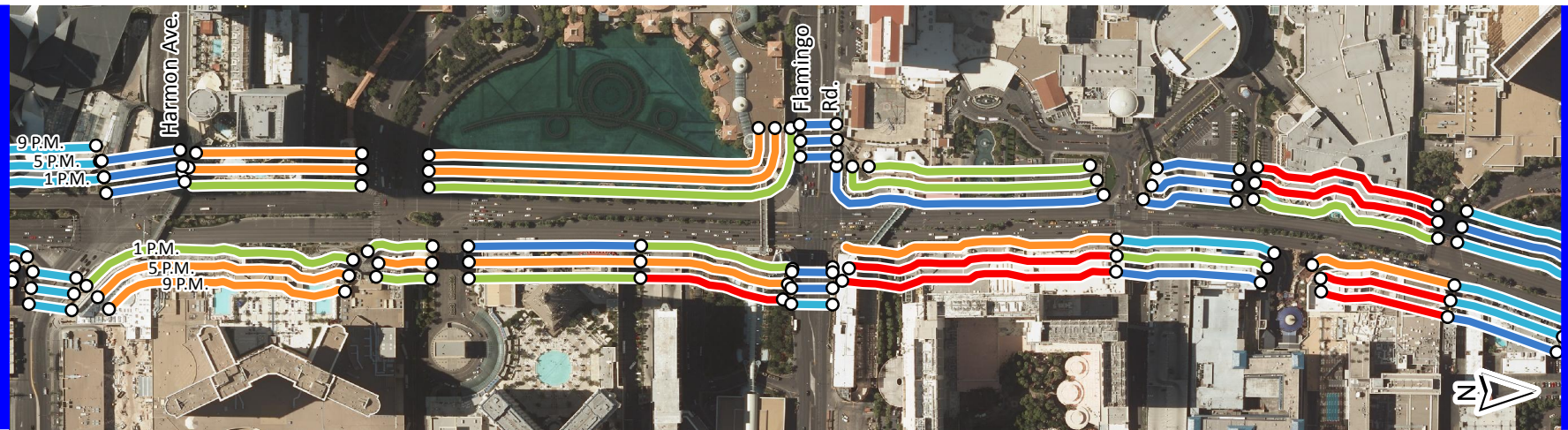

SEE ABOVE RIGHT

SEE RIGHT

SEE LEFT

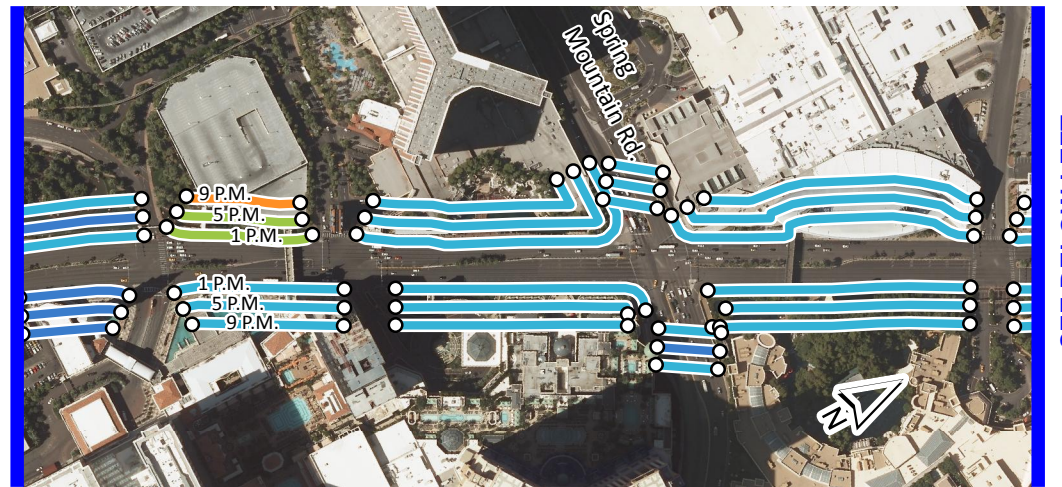



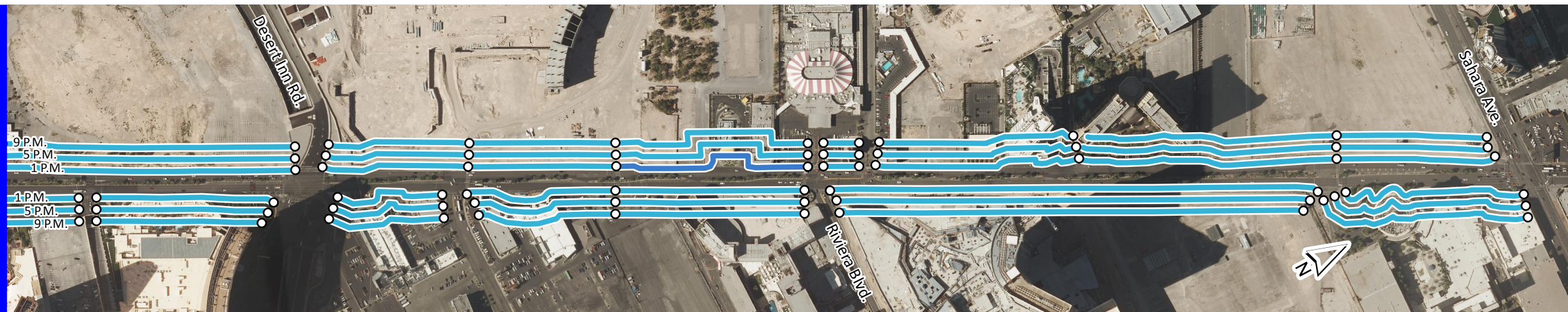



SEE BELOW LEFT



SEE ABOVE RIGHT

Legend

Avg. Non-Permanent Obstructions

-  2 or less
-  3 - 6
-  7 - 10
-  11 - 14
-  Greater than 14
-  Segment Limits

**AVERAGE NON-PERMANENT OBSTRUCTIONS PER SEGMENT
SATURDAY MAY 26, 2012**

FIGURE 3.51 92

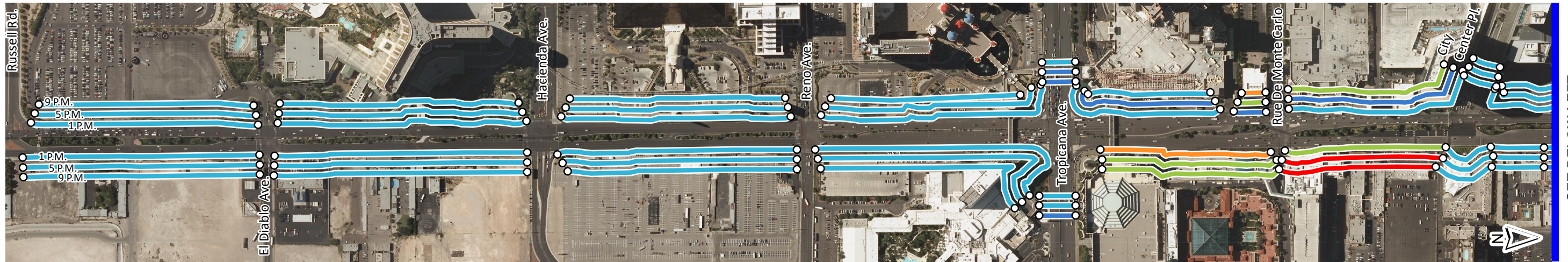

SEE BELOW LEFT

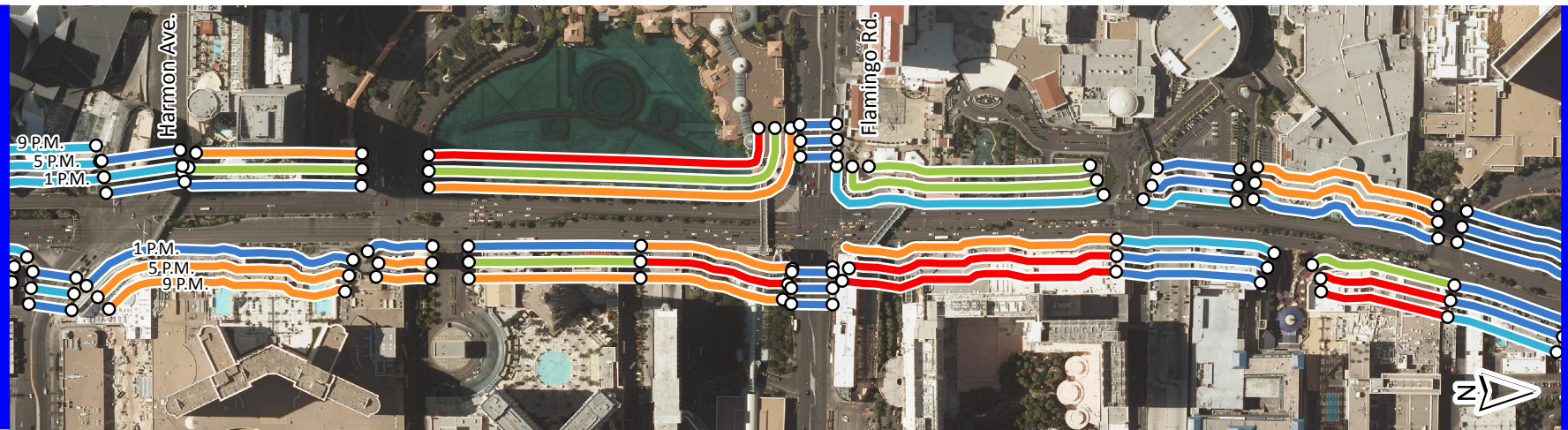

SEE ABOVE RIGHT

SEE RIGHT

SEE LEFT

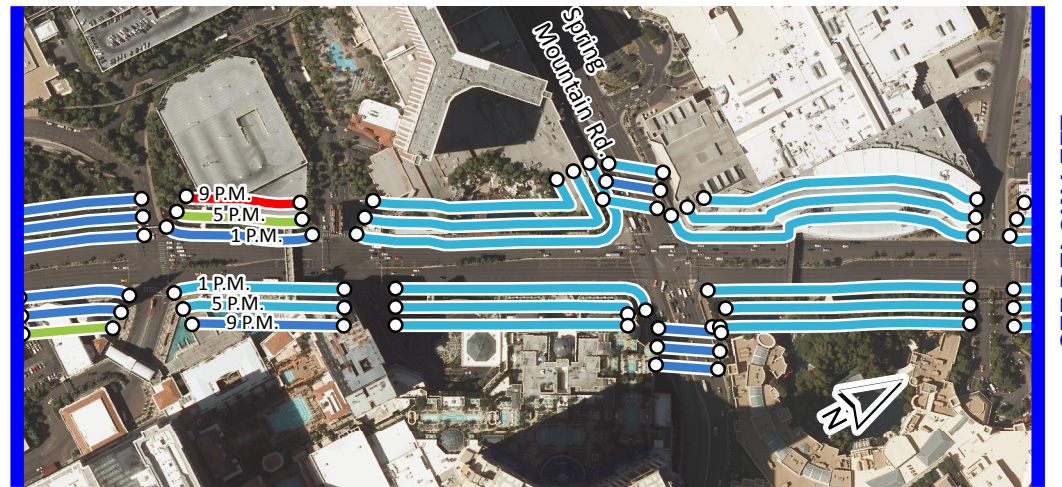



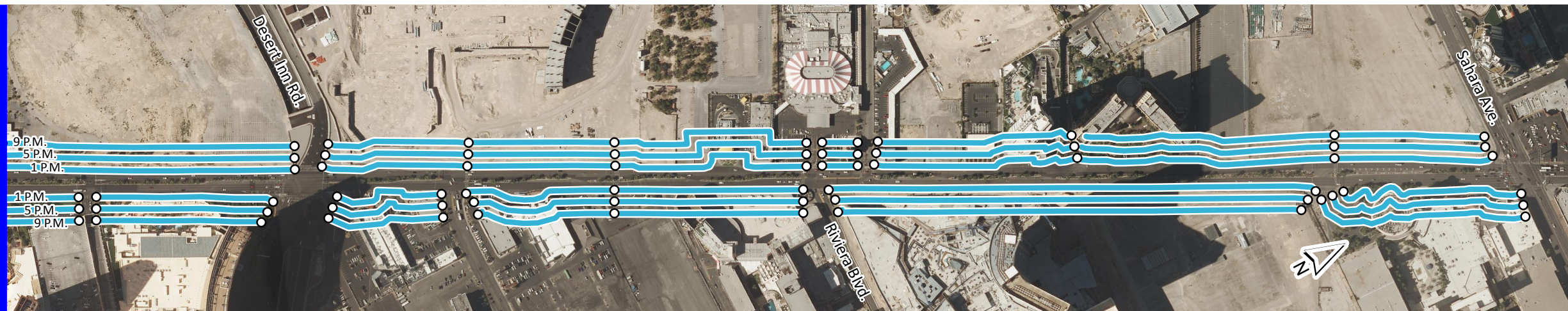



SEE BELOW LEFT



SEE ABOVE RIGHT

Legend

Avg. Non-Permanent Obstructions

-  2 or less
-  3 - 6
-  7 - 10
-  11 - 14
-  Greater than 14
-  Segment Limits

**AVERAGE NON-PERMANENT OBSTRUCTIONS PER SEGMENT
SATURDAY JUNE 16, 2012**

FIGURE 3.52 93

East Strip Non-Permanent Obstructions by Segment Holiday Saturday 5/26/2012

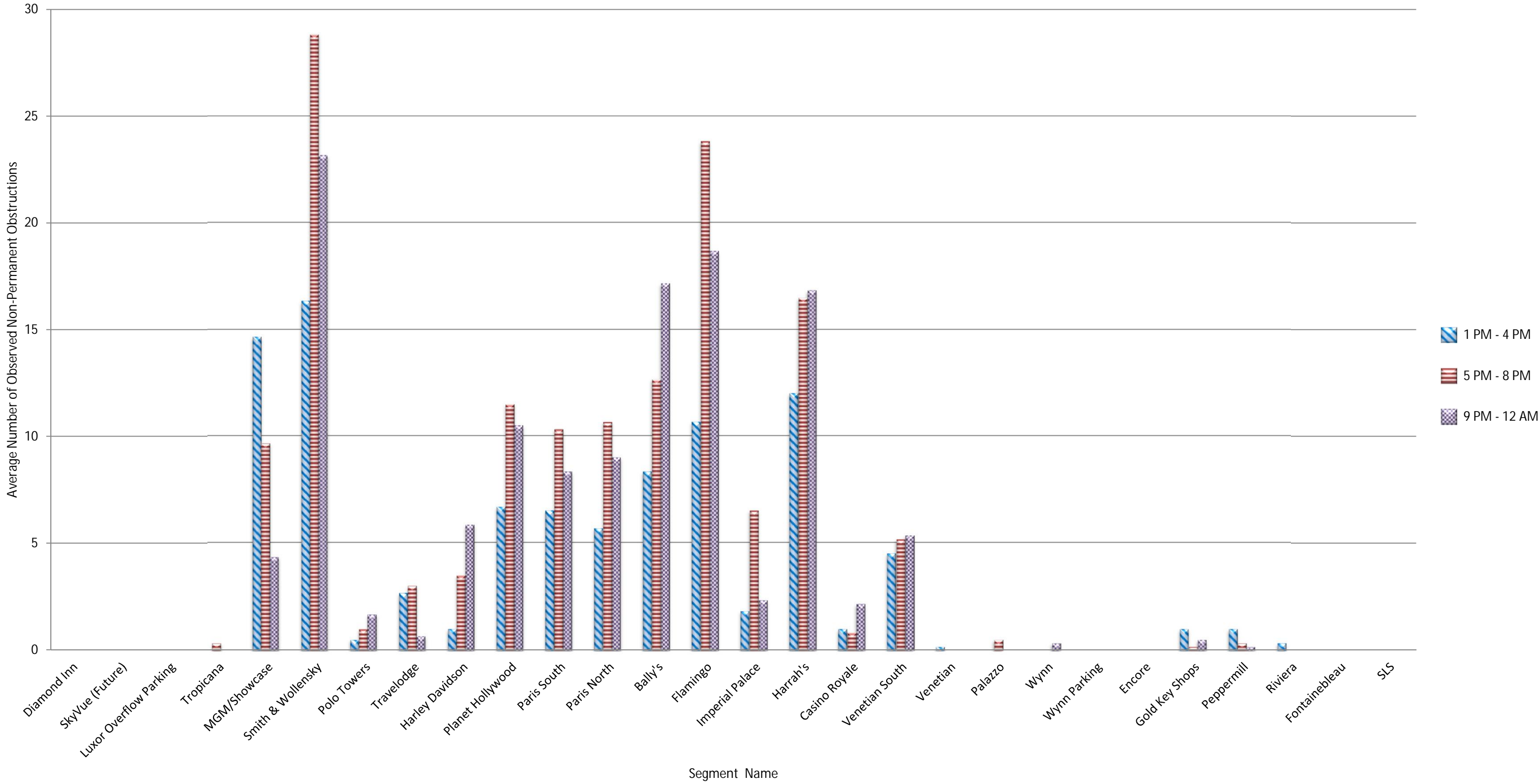

NON-PERMANENT OBSTRUCTIONS

West Strip Non-Permanent Obstructions by Segment Holiday Saturday 5/26/2012

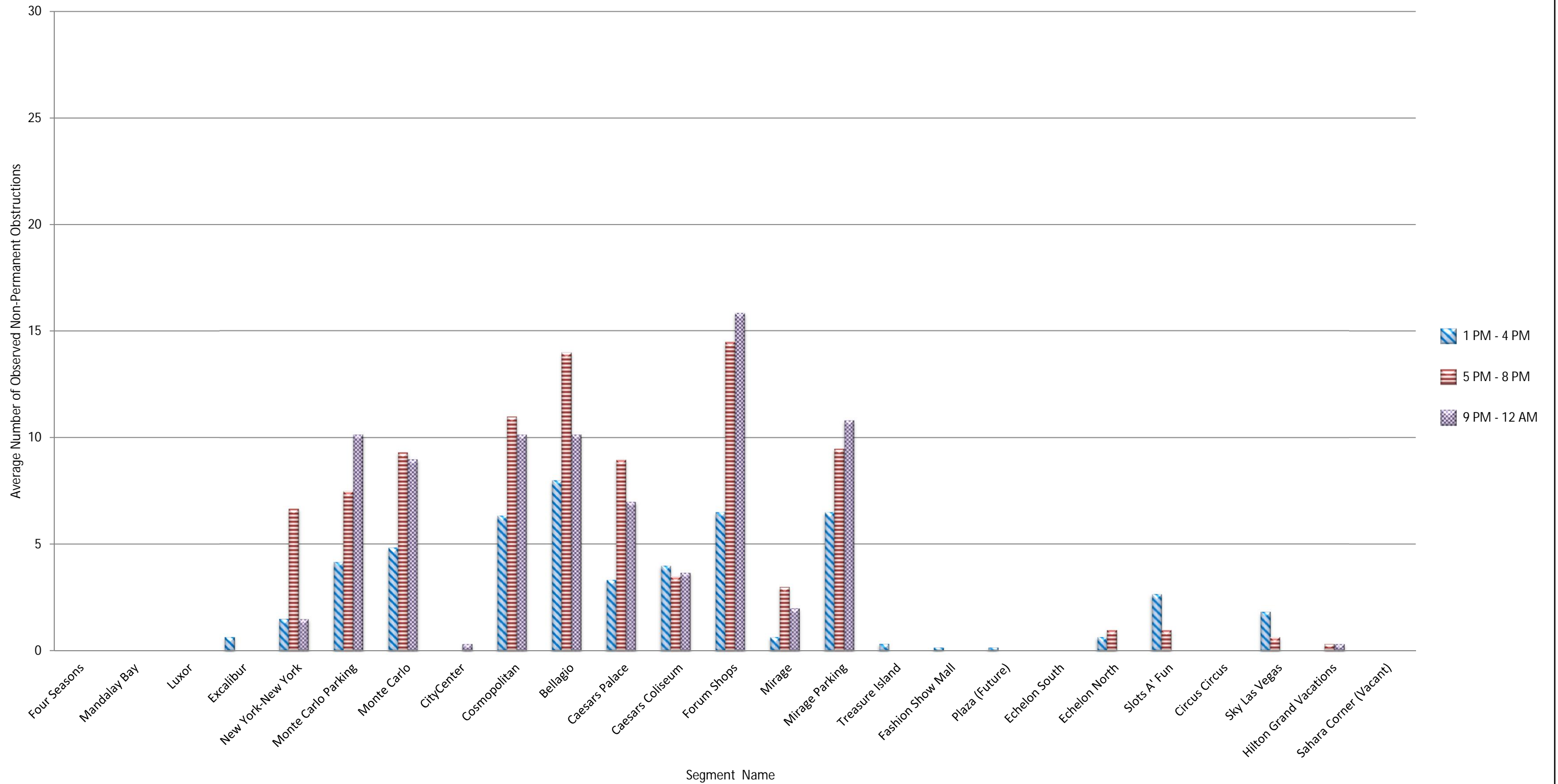

NON-PERMANENT OBSTRUCTIONS

East Strip Non-Permanent Obstructions by Segment Typical Saturday 6/16/2012

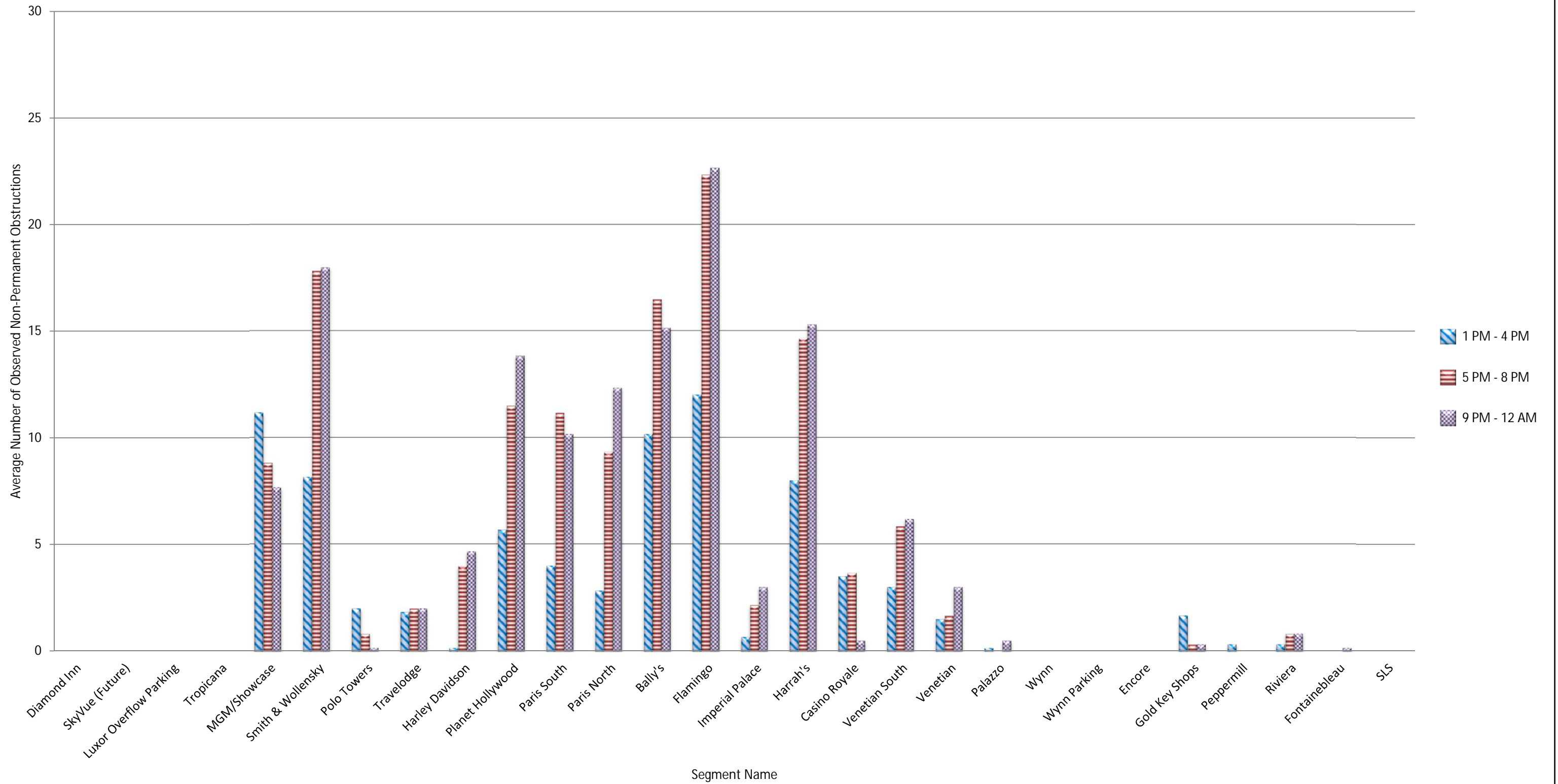

NON-PERMANENT OBSTRUCTIONS

West Strip Non-Permanent Obstructions by Segment
 Typical Saturday 6/16/2012

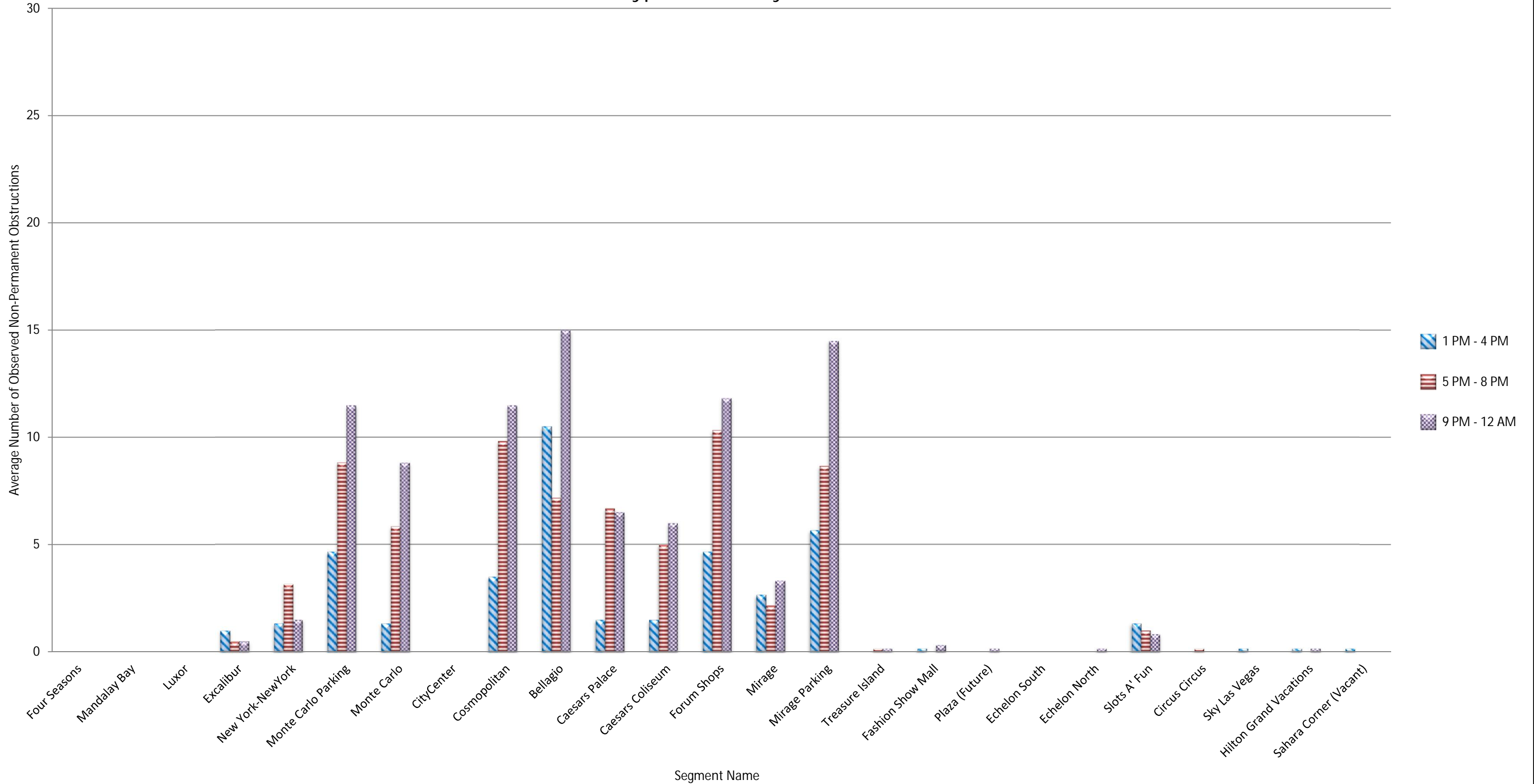

NON-PERMANENT OBSTRUCTIONS

3.3.2 Non-Permanent Obstructions on Pedestrian Bridges

A separate evaluation was conducted for non-permanent obstructions observed on the 16 pedestrian bridges within the study area. The maximum number of individuals identified to be non-permanent obstructions on the pedestrian bridges was observed to be five on the Tropicana Road north pedestrian bridge between the New York-New York Hotel/Casino and the MGM Grand Hotel/Casino.

Table 3.25 through Table 3.28 summarize the average observed number of non-permanent obstructions on each pedestrian bridge from Russell Road to Sahara Avenue. It is important to note that the term “non-permanent obstruction”, for the purposes of this report, is defined as an individual who could obstruct the pedestrian walkway while engaging in any of the following activities within the walkway: hand billing, performing, soliciting or selling.

Table 3.25 – Non-Permanent Obstructions on West Pedestrian Bridges – Holiday Saturday (5/26/2012)

Pedestrian Bridge	Avg. Number of Non-Permanent Obstructions		
	1PM - 4PM	5PM - 8PM	9PM - 12AM
Tropicana West	3	4	4
CityCenter	0	0	0
Harmon West	3	3	2
Flamingo West	4	4	3
Spring Mtn West	2	1	1

Table 3.26 – Non-Permanent Obstructions on East Pedestrian Bridges – Holiday Saturday (5/26/2012)

Pedestrian Bridge	Avg. Number of Non-Permanent Obstructions		
	1PM - 4PM	5PM - 8PM	9PM - 12AM
Tropicana East	2	1	1
Harmon East	2	1	1
Flamingo East	5	3	1
Spring Mtn East	1	3	2

The holiday Saturday, May 26, and the typical Saturday, June 16, saw a similar number of non-permanent obstructions on each bridge, with slight variability on each bridge. It is important to note that these tables are composed of the average of six distinct observations on each of the north/south pedestrian bridges.

Table 3.27 – Non-Permanent Obstructions on West Pedestrian Bridges – Typical Saturday (6/16/2012)

Pedestrian Bridge	Avg. Number of Non-Permanent Obstructions		
	1PM - 4PM	5PM - 8PM	9PM - 12AM
Tropicana West	3	2	2
CityCenter	0	0	0
Harmon West	2	2	3
Flamingo West	3	3	3
Spring Mtn West	2	3	2

Table 3.28 – Non-Permanent Obstructions on East Pedestrian Bridges – Typical Saturday (6/16/2012)

Pedestrian Bridge	Avg. Number of Non-Permanent Obstructions		
	1PM - 4PM	5PM - 8PM	9PM - 12AM
Tropicana East	1	1	3
Harmon East	3	2	3
Flamingo East	5	3	3
Spring Mtn East	2	4	5

Figure 3.57 and Figure 3.58 display the average total number of non-permanent obstructions observed on pedestrian bridges for a holiday Saturday and a typical Saturday respectively. In comparing the pedestrian volume LOS on the pedestrian bridges in Table 3.3 and the average number of non-permanent obstructions on pedestrian bridges in Figure 3.57 through Figure 3.58, it can be seen that as the average number of non-permanent obstructions increased, generally, the LOS decreased when pedestrian volumes were significant. The correlation is expected as with more non-permanent obstructions, the effective walkway width (W_E) decreases and the pedestrian traffic is not provided the complete walkway width (W) for movement. Only the Flamingo Road west pedestrian bridge, between the Bellagio Hotel/Casino and Caesars Palace Hotel/Casino, was calculated to have a LOS less than LOS C on the holiday Saturday. This bridge had an average of three non-permanent obstructions throughout the day.

It is important to note that on average, the Flamingo Road west pedestrian bridge had three non-permanent obstructions on the bridge in each of the data collection periods while it experienced LOS D volume conditions and LOS F walking speed conditions. This suggests that at least where pedestrian volumes are large, non-permanent obstructions are contributing to deteriorated walking speeds and congestion. Picture 3.15 and Picture 3.16 show pedestrian bridges with non-permanent obstructions at Flamingo Road and Tropicana Avenue respectively.



Picture 3.15 – Non-Permanent Obstructions (vendors) on Pedestrian Bridge – Flamingo Road East.



Picture 3.16 – Non-Permanent Obstructions (solicitor/vendor) on Pedestrian Bridge – Tropicana Avenue West.

Non-Permanent Obstructions by Pedestrian Bridge Holiday Saturday 5/26/2012

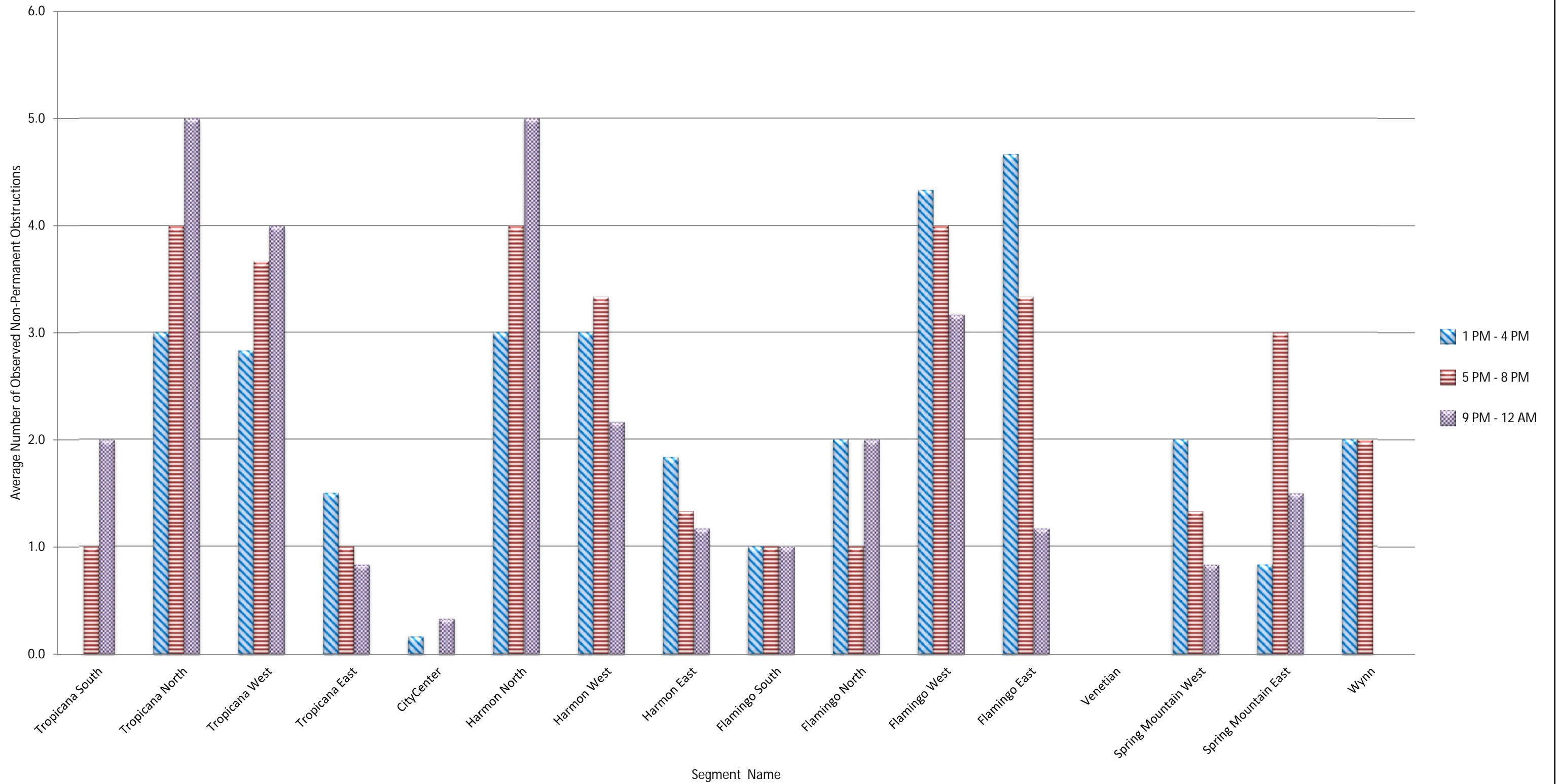

NON-PERMANENT OBSTRUCTIONS

Non-Permanent Obstructions by Pedestrian Bridge Typical Saturday 6/16/2012

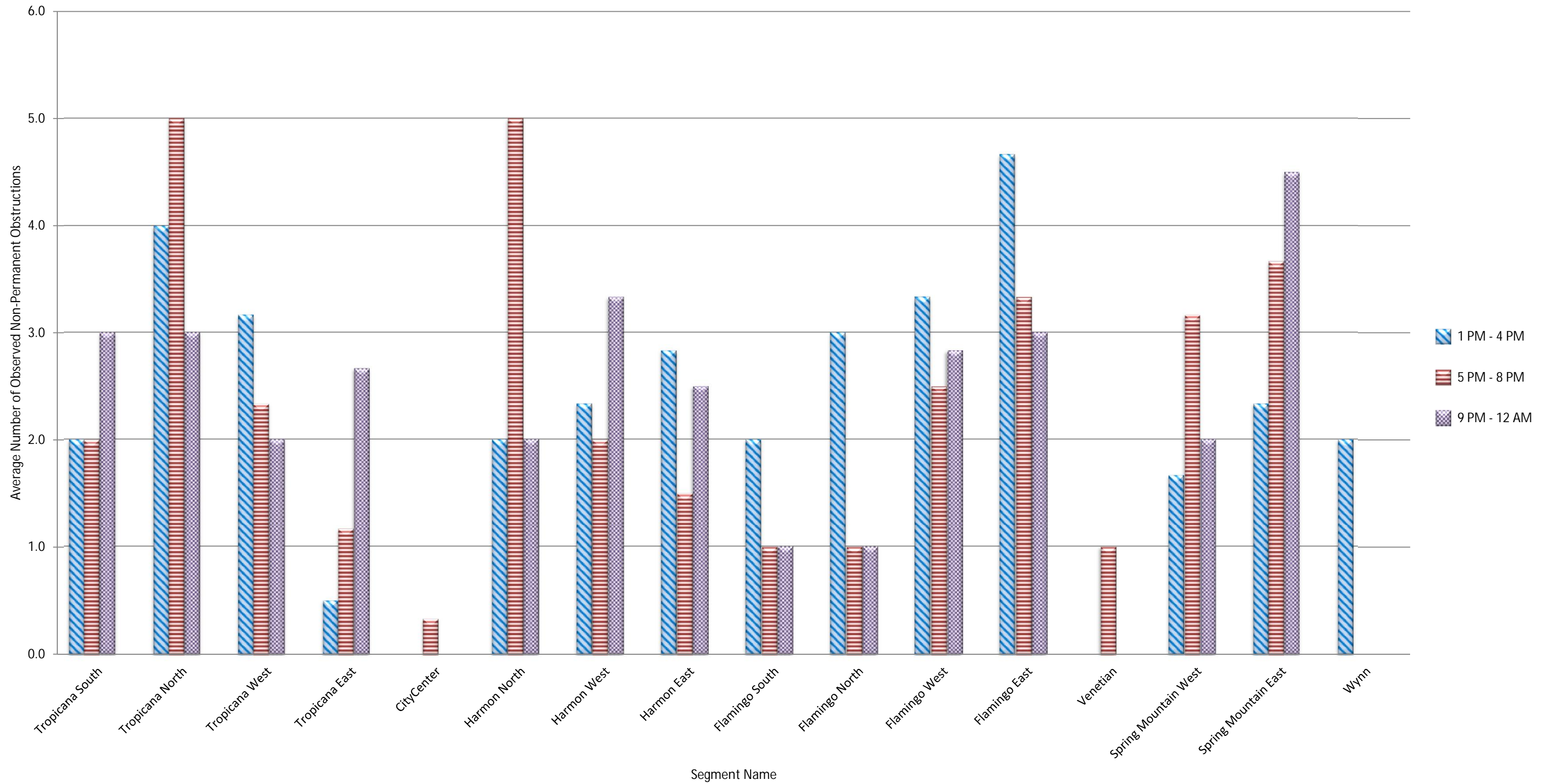

NON-PERMANENT OBSTRUCTIONS

3.4 Bus Stop Queuing

Type 3 bus stops which have the bus shelter and queuing area behind the pedestrian walkway have the concern of congestion when transit passengers are boarding and alighting the bus and potentially while waiting for the bus to arrive (see Picture 3.17). Similarly, Type 2 bus stops have queue areas outside the stream of pedestrian traffic (see Picture 3.18). Type 1 bus stops have separate queuing areas that are isolated from the pedestrian walkway and bus queuing does not affect the pedestrian flow in these locations. The maximum 15-minute boarding number was evaluated at each Type 3 bus stop and at Type 2 bus stops that were observed to potentially be of concern. In some cases, where bus queuing is intense, queues overcrowd the queuing area and spill into the pedestrian walkway. Bus stops were not further analyzed if 375 or less pedestrians per 15-minutes were observed during the Memorial Day holiday weekend (May 26, 2012) passing by the bus stop. A volume of 375 pedestrians in 15 minutes requires an effective walkway width of 2.5 feet to maintain a LOS C. The 375 pedestrian volume is based on the pedestrian volume capacity of a four-foot walkway with LOS C. Bus stops were also excluded from further evaluation if the maximum 15-minute boarding was less than 15 people. For 15 people, the queue space is calculated to be 105 square feet at 7.0 square feet per person for a Queuing LOS of C.

Analysis of the ridership data from both the holiday, May 26 and typical, June 16, Saturday indicated that the bus stops listed in Table 3.29 be further evaluated:

Table 3.29 – Bus Stops Included in Queuing Analysis

Bus Stop	Type
Polo Towers North	3
Bellagio South	3
Paris North	2
Flamingo North	2
Caesars Palace South	2
Mirage South	2
Treasure Island South	3
Venetian North	2

Of the eight stops identified for analysis, six had a maximum 15-minute boarding on the holiday Saturday (May 26, 2012) while the remaining two had maximum boardings on the typical Saturday (June 16, 2012). The maximum boarding volumes were used in the evaluation of the bus stop queuing areas. Figure 3.59 and Figure 3.60 show the bus stop locations, types, as well as the maximum 15-minute boarding for both data collection dates (see also Figure 2.6 for stop location and type). To maintain a queue space of LOS C or better, each person in a bus stop queue area requires a minimum of seven square feet. This distance allows for an 18-inch no-touch zone for each queued person. Table 3.30 shows the maximum queues at each of the identified bus stops and the queue area required for LOS C to serve that maximum queue.

Table 3.30 – Bus Stop Max Boardings and Queue Area

Bus Stop	Day	Maximum 15-minute volume	Maximum 15-minute boardings	Demand Queue Area (sq. ft.)	Existing Queue Area (sq. ft.)
Polo Towers N	6/16	1,290	33	231	265
Bellagio S	5/26	2,633	59	413	900
Paris N	5/26	2,124	82	574	260
Flamingo N	5/26	1,459	41	287	375
Caesars S	5/26	1,684	27	189	321
Mirage S	6/16	1,963	35	245	279
Treasure Island S	5/26	1,016	41	287	148
Venetian N	5/26	1,737	58	406	312

Bold Value – Demand Queue Exceeds Existing Area

Evaluation of the individual bus stops showed that the bus stops in Table 3.31 have adequate queue area within and in front of the shelter. For Type 3 bus stops (with bus shelter behind the pedestrian walkway), a minimum four-foot walk was calculated to be provided.

Table 3.31 – Analyzed Bus Stops with Adequate Queue Area

Bus Stop	Type
Polo Towers N	3
Bellagio S	2
Flamingo N	2
Caesars S	2
Mirage S	2

The remaining bus stops lack the amount of queue space that is desired for the maximum boardings while maintaining a LOS C queue area. These bus stops are included in Table 3.32.

Table 3.32 – Analyzed Bus Stops with Inadequate Queue Area

Bus Stop	Type
Paris N	2
Treasure Island S	3
Venetian N	2

The LOS evaluation suggests that where insufficient queue area is identified, 15 feet on either side and in front of the bus shelter should be reserved for bus patrons by restricting non-permanent obstructions. The LOS evaluation also concluded that all Type 2 and Type 3 bus stops should allow the area between the queue area and the curb to be available for only queued and walking pedestrians with a delineated no-obstructive use zone. In addition, from field observations, all Type 1 bus stops should also be considered for no-obstructive use zones to encourage transit use by maintaining queue areas of LOS C or better and aiding pedestrian flow in front of Type 1 bus stops.



Picture 3.17 – Type 2 Bus Stop – In Front of Walkway.



Picture 3.18 – Type 3 Bus Stop – Behind Walkway.

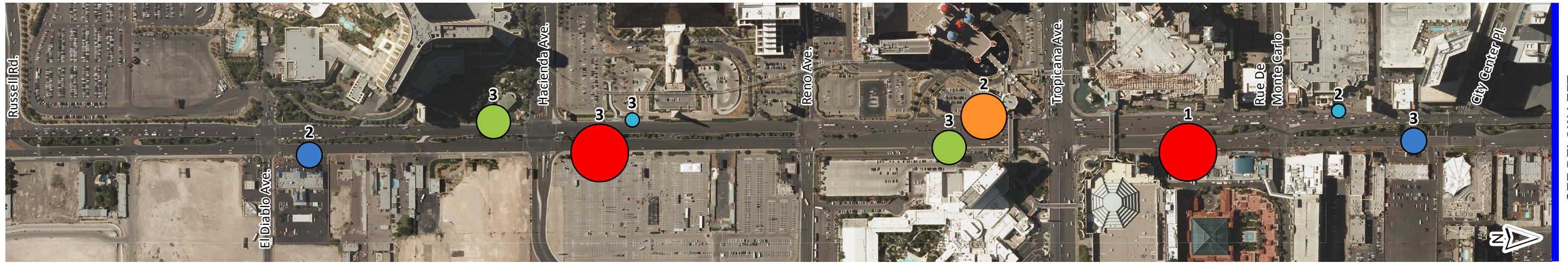

SEE BELOW LEFT



SEE ABOVE RIGHT

SEE RIGHT

SEE LEFT

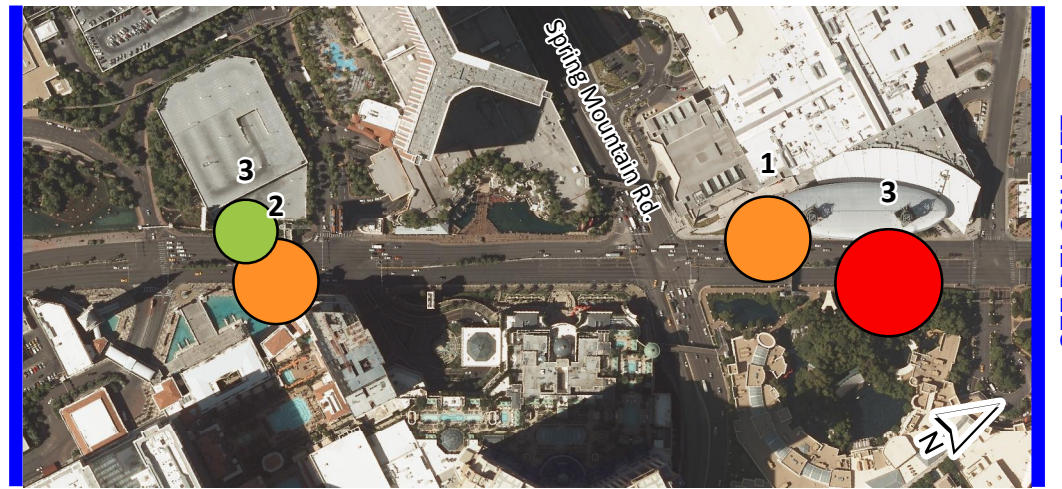



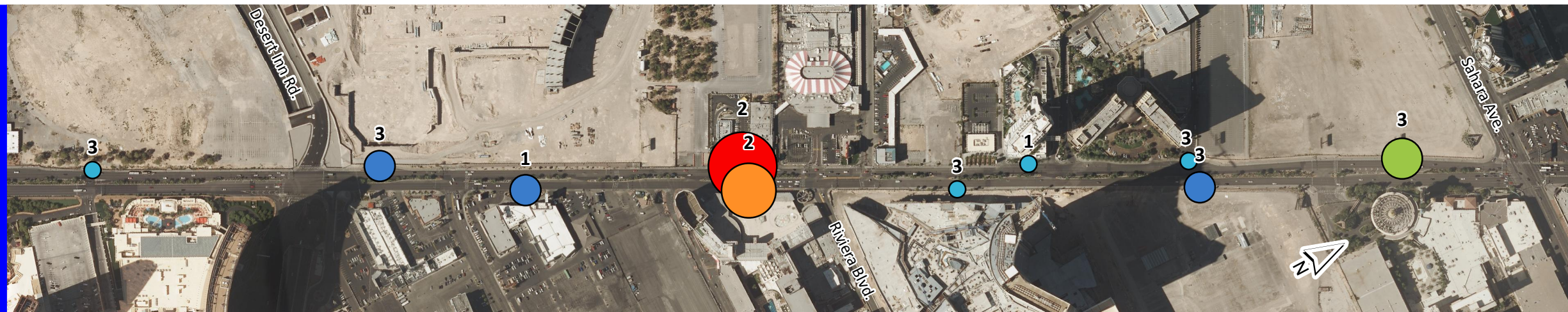

SEE BELOW LEFT



SEE ABOVE RIGHT

Legend

Bus Boardings

-  15 or Less
-  16 - 30
-  31 - 45
-  46 - 60
-  Greater than 60

- 1: Isolated
- 2: In Front of Walk
- 3: Behind Walk

MAX PEAK 15-MINUTE BUS BOARDINGS - MAY 26, 2012

FIGURE 3.59 102

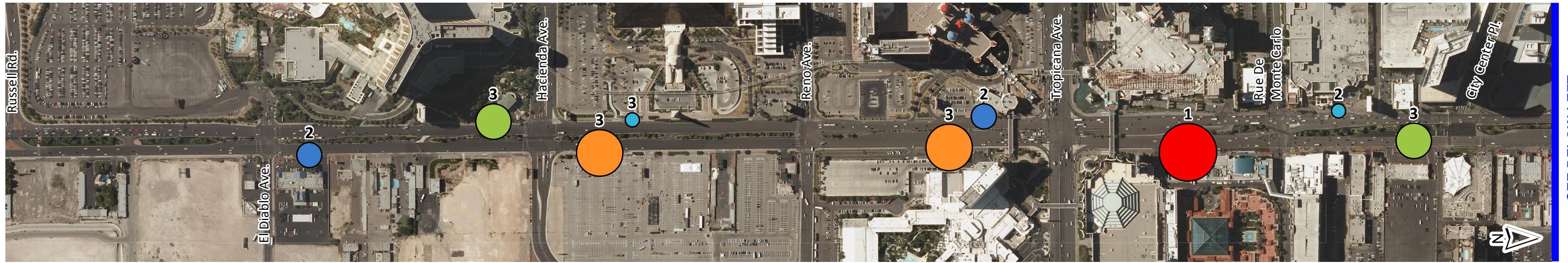

SEE BELOW LEFT



SEE ABOVE RIGHT

SEE RIGHT

SEE LEFT

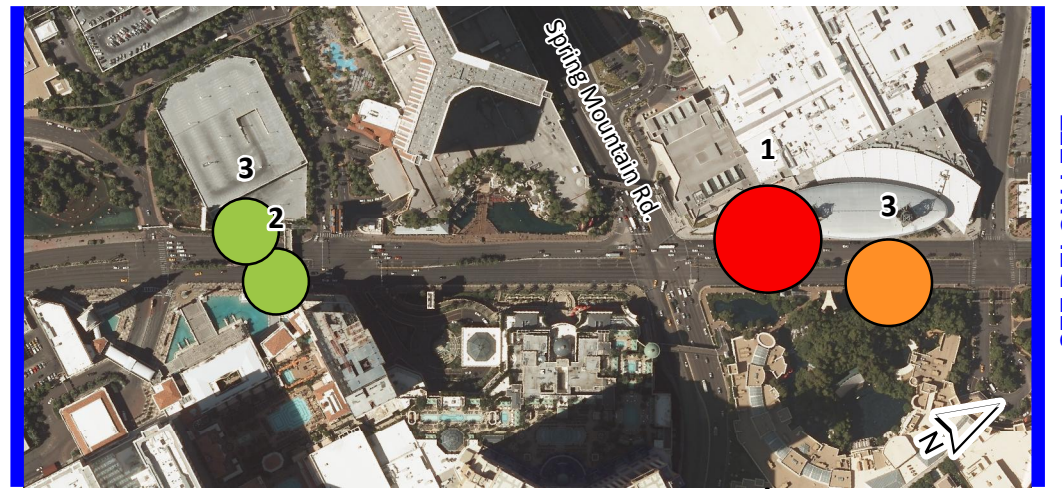

SEE BELOW LEFT

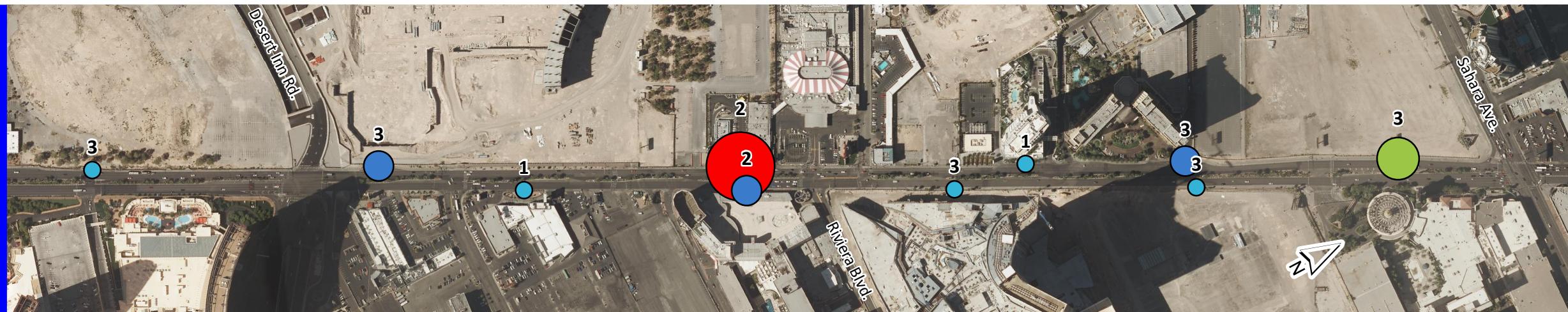

SEE ABOVE RIGHT

Legend

Bus Boardings

- 15 or Less
- 16 - 30
- 31 - 45
- 46 - 60
- Greater than 60

- 1: Isolated
- 2: In Front of Walk
- 3: Behind Walk

MAX PEAK 15-MINUTE BUS BOARDINGS - JUNE 16, 2012

FIGURE 3.60 103

3.5 Pedestrian Simulation Modeling

The Advanced Land-Transportation Performance Simulation™ (ALPS™) software was used to simulate pedestrian activity based on pedestrian volumes, speeds, and group size, among other variables. After discussions with Clark County, the following locations were chosen for pedestrian simulation modeling with ALPS™:

- Model 1 – Pedestrian Bridge
- Model 2 – Sidewalk
- Model 3 – Sidewalk and Bus Stop
- Model 4 – Queuing at a signalized Crosswalk

The four models are anticipated to represent the general types of situations that are currently occurring along “typical” sections of Las Vegas Boulevard. The different model sections were analyzed with and without non-permanent obstructions. For modeling purposes, the actual activity of the non-permanent obstruction was not analyzed, only the space taken up by the obstruction and its impact on the adjacent walkway width was evaluated. In other words, the modeling does not represent any specific type of non-obstructive activity. Based on information contained in the HCM, obstructions along edges of the walkways were considered to take up 2.25 feet by 10 feet (22.5 square feet) and obstructions in the center of walkways were considered to take up 3.5 feet by 7.5 feet (26.25 square feet). Figure 3.61 illustrates the pedestrian obstruction sizes utilized in the analysis.

Figure 3.61 – Pedestrian Obstruction Sizes

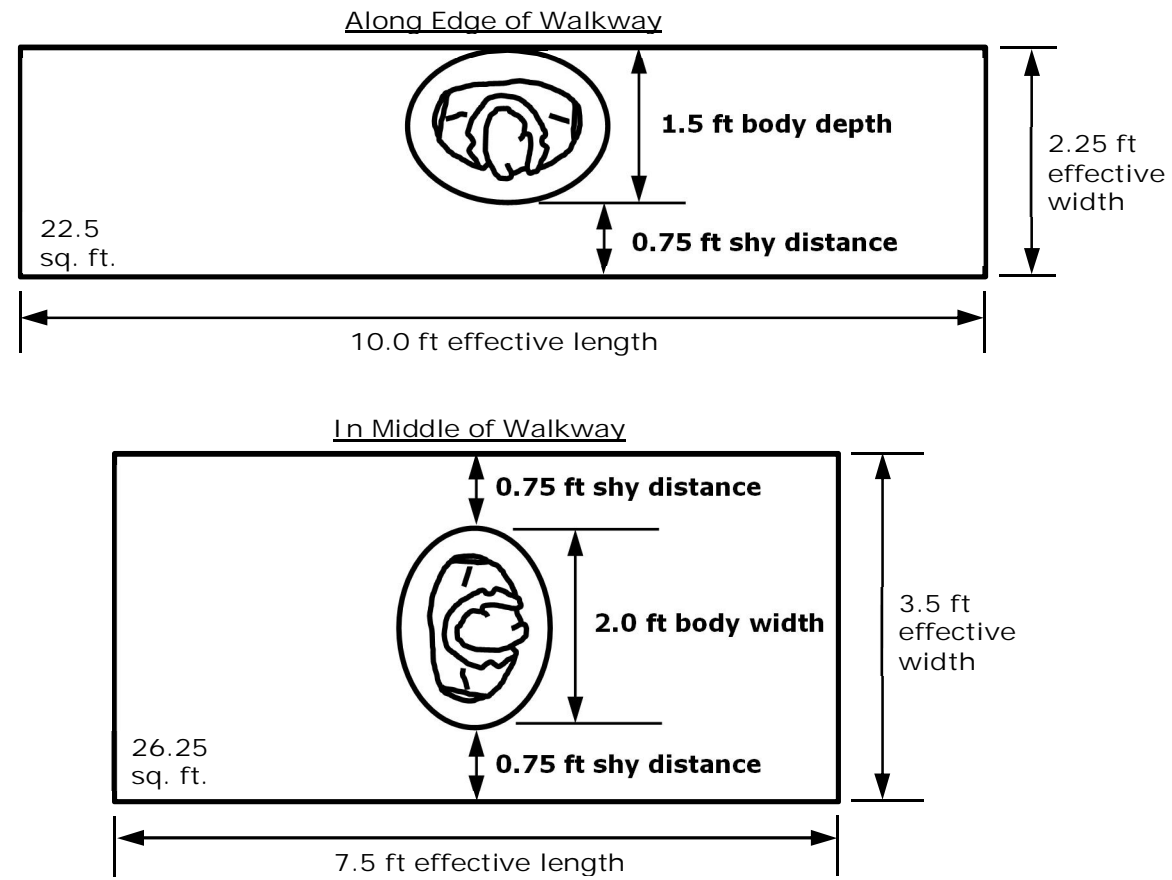

The following sections outline the four modeling locations, scenarios, and model input data.

3.5.1 Model 1 – Pedestrian Bridge

Model 1 – Pedestrian Bridge represents a segment of the Flamingo Road west pedestrian bridge between the escalators south of Caesars Palace Hotel/Casino and north of the Bellagio Hotel/Casino. Figure 3.62 illustrates the area to be analyzed. Only the bridge walkway portion over Flamingo Road was included in the model (escalators, stairs, and elevators were not included in the model). The following scenarios were analyzed:

- Scenario A – No obstructions
- Scenario B – With obstructions along the walls (three obstructions total)
- Scenario C – With obstructions along the walls and in the center of the walkway (four obstructions total)

Scenarios B and C are consistent with the number of obstructions observed on this bridge section during the study. Table 3.33 summarizes the 15-minute pedestrian volume input data for Model 1 – Pedestrian Bridge.

Table 3.33 – Model 1 – Pedestrian Bridge Input Data -15-Minute Pedestrian Volume

Start Time	South bound	North bound	Start Time	South bound	North bound
3:00 PM	651	570	7:30 PM	707	642
3:15 PM	595	441	7:45 PM	861	666
3:30 PM	935	694	8:00 PM	793	581
3:45 PM	1,083	867	8:15 PM	707	958
4:00 PM	881	745	8:30 PM	953	950
4:15 PM	852	729	8:45 PM	886	908
4:30 PM	873	838	9:00 PM	1128	810
4:45 PM	739	671	9:15 PM	1,002	1143
5:00 PM	770	777	9:30 PM	1155	1015
5:15 PM	817	783	9:45 PM	980	1029
5:30 PM	772	848	10:00 PM	999	1002
5:45 PM	1,010	765	10:15 PM	772	1004
6:00 PM	810	996	10:30 PM	927	873
6:15 PM	797	641	10:45 PM	898	617
6:30 PM	949	846	11:00 PM	893	479
6:45 PM	746	755	11:15 PM	973	904
7:00 PM	907	735	11:30 PM	1101	781
7:15 PM	781	683	11:45 PM	831	761

Average walking speed: 2.61 feet per second (see Section 3.2.1)
 Pedestrian speed and volume data from Saturday, May 26, 2012
 (Memorial Day weekend) Count Location ID: 11
 Location: the Flamingo Road west pedestrian bridge between the escalators south of Caesars Palace Hotel/Casino and north of the Bellagio Hotel/Casino

Figure 3.62 – Model 1 – Pedestrian Bridge



3.5.2 Model 2 – Sidewalk

Model 2 – Sidewalk is a segment of a sidewalk in front of Caesars Palace Hotel/Casino, north of Caesars Palace Boulevard and south of the Forum Shops. This section of sidewalk was identified to have pedestrian volumes exceeding a LOS C during the study. As such, it was identified as a representative sidewalk section for further modeling. Like many segments of sidewalk along Las Vegas Boulevard, this segment of sidewalk is constrained on both sides of the pedestrian walkway. Figure 3.63 illustrates the area to be analyzed by ALPS modeling. The following scenarios were analyzed:

- Scenario A – No obstructions
- Scenario B – With obstructions along the outside of the sidewalk (three obstructions total)

Table 3.34 summarizes the 15-minute pedestrian volume input data for Model 2 – Sidewalk.

Table 3.34 – Model 2 – Sidewalk Input Data -15-Minute Pedestrian Volume

Start Time	South bound	North bound	Start Time	South bound	North bound
3:00 PM	731	763	7:30 PM	776	980
3:15 PM	752	788	7:45 PM	808	1150
3:30 PM	692	823	8:00 PM	709	990
3:45 PM	756	776	8:15 PM	752	984
4:00 PM	730	793	8:30 PM	755	1017
4:15 PM	714	802	8:45 PM	811	1121
4:30 PM	733	774	9:00 PM	733	980
4:45 PM	758	816	9:15 PM	915	967
5:00 PM	777	796	9:30 PM	855	976
5:15 PM	794	842	9:45 PM	984	960
5:30 PM	789	830	10:00 PM	643 *	563 *
5:45 PM	810	767	10:15 PM	808 *	562 *
6:00 PM	781	634	10:30 PM	872 *	494 *
6:15 PM	804	519	10:45 PM	997 *	460 *
6:30 PM	800	626	11:00 PM	755 *	293 *
6:45 PM	705	468	11:15 PM	1,101 *	570 *
7:00 PM	731	719	11:30 PM	907	1184
7:15 PM	809	623	11:45 PM	726	750

Average walking speed: 3.23 feet per second (see Section 3.2)

Pedestrian speed and volume data from Saturday, May 26, 2012 (Memorial Day weekend)

Location: Sidewalk in front of Caesars Palace Hotel/Casino, north of Caesars Palace Boulevard and south of the Forum Shops

*Pedestrian volumes estimated from Caesars Palace manual count location: M6.

Figure 3.63 – Model 2 – Sidewalk



3.5.3 Model 3 – Sidewalk and Bus Stop

Model 3 – Sidewalk and Bus Stop is located at the Treasure Island bus stop south of Siren’s Cove Boulevard and north of The Mirage Hotel/Casino north entrance. As identified in Section 2.1.4, this bus stop is a Type 3 configuration with the bus shelter at the back of the walkway. For the model, the pedestrians are constrained to the walkway. It is important to note that during the observations, it was documented that pedestrians spill out onto Las Vegas Boulevard during peak congestion time periods (see Picture 3.19). Figure 3.64 illustrates the area to be analyzed. The following scenarios were analyzed:

- Scenario A – No obstructions
- Scenario B – With obstructions along the outside of the sidewalk (three obstructions total)

Table 3.35 summarizes the sidewalk 15-minute pedestrian volume input data for Model 3 – Sidewalk and Bus Stop, and Table 3.36 summarizes the boarding and alighting data received from the RTC for the TI bus stop.

Table 3.35 – Model 3 – Sidewalk Input Data -15-Minute Pedestrian Volume

Start Time	South bound	North bound	Start Time	South bound	North bound
3:00 PM	448	351	7:30 PM	615	603
3:15 PM	558	403	7:45 PM	503	634
3:30 PM	430	435	8:00 PM	294	661
3:45 PM	503	440	8:15 PM	1,016	598
4:00 PM	519	433	8:30 PM	952	913
4:15 PM	488	457	8:45 PM	1008	955
4:30 PM	556	467	9:00 PM	949	983
4:45 PM	519	489	9:15 PM	953	993
5:00 PM	506	503	9:30 PM	918	975
5:15 PM	487	526	9:45 PM	603	967
5:30 PM	518	540	10:00 PM	841	904
5:45 PM	563	552	10:15 PM	901	899
6:00 PM	622	590	10:30 PM	893	919
6:15 PM	637	609	10:45 PM	939	945
6:30 PM	603	626	11:00 PM	601	960
6:45 PM	611	655	11:15 PM	849	852
7:00 PM	619	679	11:30 PM	1011	702
7:15 PM	607	640	11:45 PM	885	853

Average walking speed: 3.42 feet per second (see Section 3.2)

Pedestrian speed and volume data from Saturday, May 26, 2012 (Memorial Day weekend) Count Location: 15

Location: TI bus stop south of Siren’s Cove Boulevard and north of The Mirage’s north entrance

Table 3.36 – Model 3 – Bus Stop Boarding and Alighting Data – 15-Minute Boarding/Alighting

Start Time	Boarding	Alighting	Start Time	Boarding	Alighting
3:00 PM	26	15	7:30 PM	14	6
3:15 PM	14	20	7:45 PM	17	19
3:30 PM	26	25	8:00 PM	8	7
3:45 PM	28	27	8:15 PM	4	2
4:00 PM	15	7	8:30 PM	0	4
4:15 PM	11	26	8:45 PM	21	9
4:30 PM	5	20	9:00 PM	13	41
4:45 PM	9	19	9:15 PM	14	24
5:00 PM	15	15	9:30 PM	0	5
5:15 PM	11	5	9:45 PM	6	2
5:30 PM	4	0	10:00 PM	14	60
5:45 PM	33	13	10:15 PM	15	31
6:00 PM	8	20	10:30 PM	28	7
6:15 PM	15	13	10:45 PM	2	30
6:30 PM	28	12	11:00 PM	15	28
6:45 PM	24	35	11:15 PM	6	26
7:00 PM	12	5	11:30 PM	10	30
7:15 PM	6	13	11:45 PM	14	18

Source: Regional Transportation Commission of Southern Nevada bus stop data from Saturday, May 26, 2012
(Bus schedule is currently providing 12-15 minute headway service)

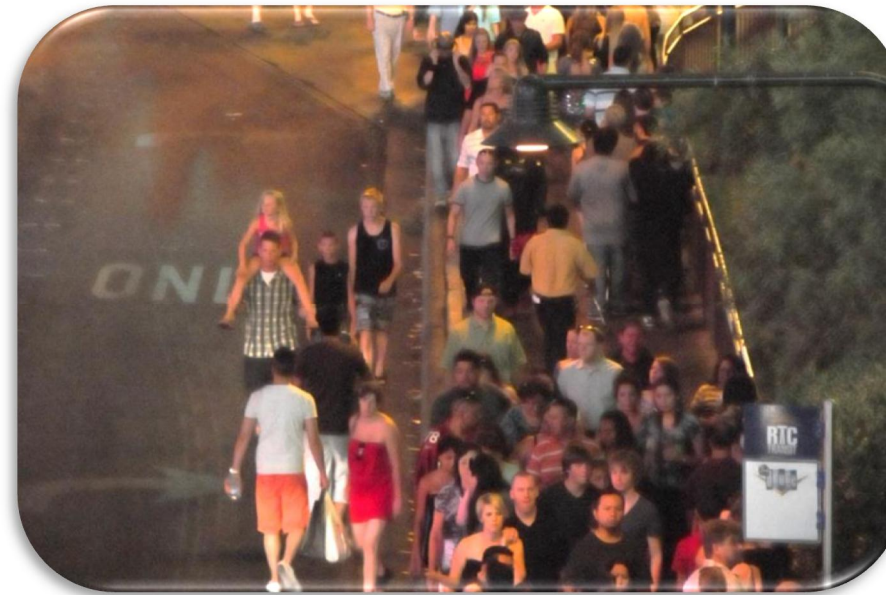

Picture 3.19 – Pedestrian Activity between Mirage and TI after Volcano Show and before Siren Show.

Figure 3.64 – Model 3 – Sidewalk and Bus Stop



3.5.4 Model 4 – Queuing at a Signalized Crosswalk

Model 4 – Queuing at a Signalized Crosswalk is located in the northeast quadrant of the intersection of Las Vegas Boulevard and Rue de Monte Carlo, near the Showcase Mall. Only pedestrian activity is simulated along with their interaction with crosswalk signal timing. Vehicles are not simulated or included in the model. Figure 3.65 illustrates the area to be analyzed. The following scenarios were analyzed:

- Scenario A – Permanent obstructions
- Scenario B – With obstructions along the outside of the sidewalk and permanent obstructions (three obstructions total)
- Scenario C – No obstructions (permanent obstructions removed)

Table 3.37 summarizes the sidewalk 15-minute pedestrian volume input data for Model 4 – Queuing at a Signalized Crosswalk (where SB, EB and NB signify south, east and northbound and T, R and L are thru, right and left).

Table 3.37 – Model 4 – Queuing at a Signalized Intersection Input Data -15-Minute Pedestrian Volume

Start Time	SB		NB		EB		Start Time	SB		NB		EB	
	T	R	L	T	L	R		T	R	L	T	L	R
3:00 PM	87	299	81	591	236	92	7:30 PM	48	165	44	325	130	50
3:15 PM	85	289	72	532	212	89	7:45 PM	71	243	52	384	153	75
3:30 PM	65	224	76	559	223	69	8:00 PM	58	199	52	381	152	61
3:45 PM	64	220	63	464	185	68	8:15 PM	64	218	56	409	163	67
4:00 PM	61	207	67	492	196	64	8:30 PM	57	195	50	365	145	60
4:15 PM	96	329	75	549	219	101	8:45 PM	72	247	41	304	121	76
4:30 PM	65	221	73	535	213	68	9:00 PM	75	256	46	336	134	78
4:45 PM	61	209	60	439	175	64	9:15 PM	109	373	56	409	163	114
5:00 PM	70	239	62	457	182	73	9:30 PM	122	417	59	435	173	128
5:15 PM	78	265	66	484	193	81	9:45 PM	87	296	50	370	147	91
5:30 PM	62	212	52	384	153	65	10:00 PM	67	230	45	334	133	70
5:45 PM	78	266	59	434	173	81	10:15 PM	60	205	41	304	121	63
6:00 PM	68	232	70	515	205	71	10:30 PM	59	202	46	339	135	62
6:15 PM	72	245	63	464	185	75	10:45 PM	50	170	45	328	131	52
6:30 PM	54	184	73	534	213	56	11:00 PM	70	239	52	383	153	73
6:45 PM	59	201	68	502	200	61	11:15 PM	68	233	41	301	120	71
7:00 PM	74	254	60	437	174	78	11:30 PM	62	213	36	264	105	65
7:15 PM	57	195	52	385	153	60	11:45 PM	60	206	44	321	128	63

Average walking speed: 3.36 feet per second

Location: northeast quadrant of the intersection of Las Vegas Boulevard and Rue de Monte Carlo/MGM Drive. Count Location: 5



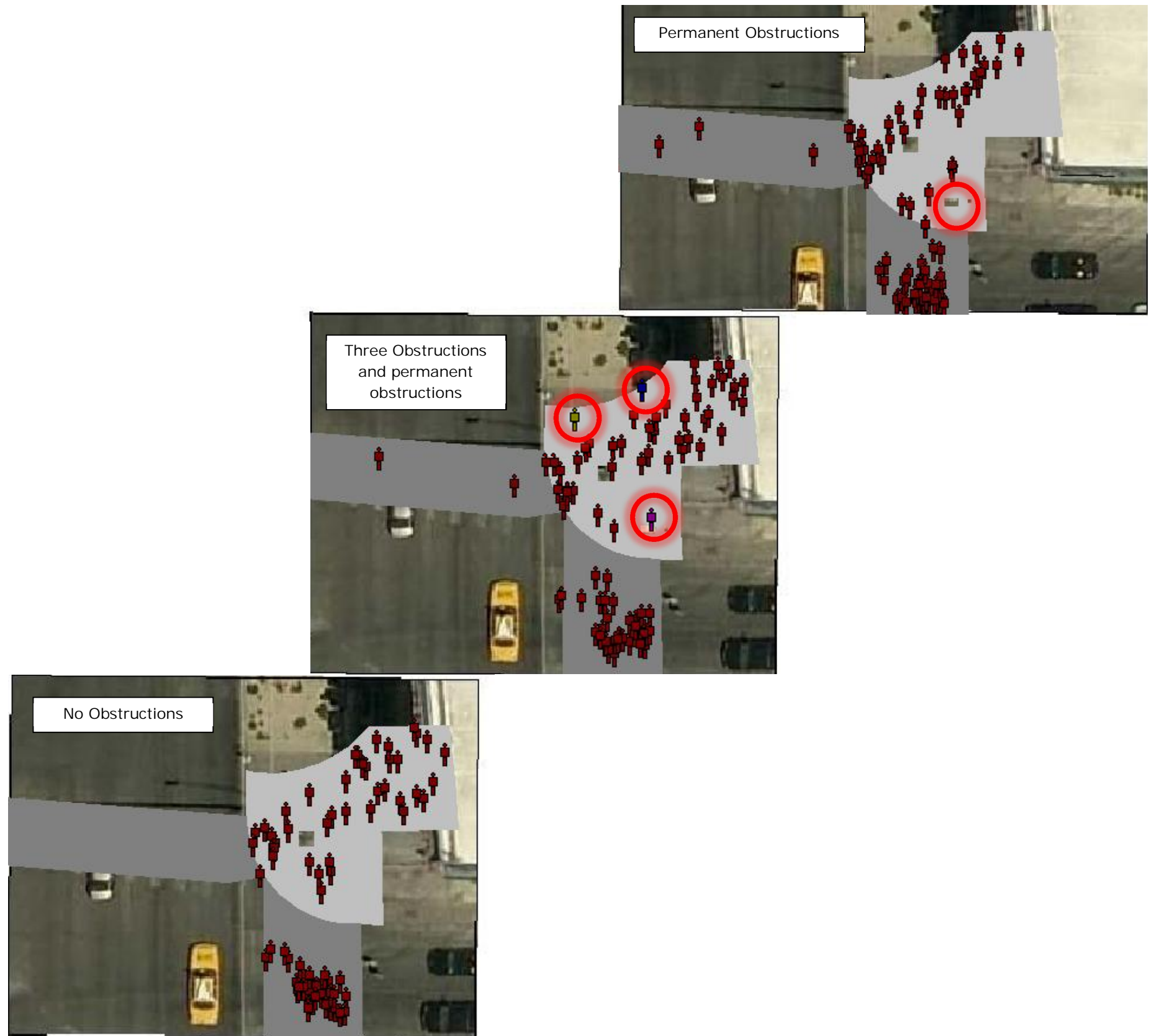



Figure 3.65 – Model 4 – Queuing at Signalized Intersection



3.5.5 Results of Pedestrian Simulation Modeling

A CD at the back of the report contains the output movies of the pedestrian simulation models and scenarios. In the various models, the pedestrian segments are color coded based on the LOS analysis for walkway segments. Table 3.38 describes the color coding by LOS for the different walkway segments. Figure 3.66 through Figure 3.69 contain screenshots of the models.

Table 3.38 – Pedestrian Simulation Modeling Color Codes

LOS	Color	Color
A	Gray	
B	Gray	
C	Gray	
D	Orange	
E	Red	
F	Red	

As shown in the pedestrian simulation model figures and attached movies, the LOS of the walkway segments is impacted by the presence of obstructions within the walkway. Table 3.39 provides data on the number of 15-minute periods where LOS C is exceeded during the model timeframe.

Table 3.39 – Model 1 Results Summary – 3:00 PM to 12:00 AM

Model	Scenario	Amount of Time LOS C is exceeded	Percent of Time LOS C is Exceeded
Model 1 – Pedestrian Bridge	No Obstructions	3.25 out of 9 hours	36%
	Side Obstructions	7 out of 9 hours	78%
	Side and Middle Obstructions	8.75 out of 9 hours	97%

Table 3.40 – Model 2 and 3 Results Summary – 3:00 PM to 12:00 AM

Model	Scenario	Percent of Time LOS C is Exceeded	Percent of Time LOS D is Exceeded	Percent of Time LOS E is Exceeded
Model 2 – Sidewalk	No Obstructions	100%	100%	44%
	Side Obstructions	100%	100%	100%
Model 3 – Sidewalk and Bus Stop	No Obstructions	100%	100%	56%
	Three Obstructions	100%	100%	100%

Figure 3.70 through Figure 3.72 illustrate the LOS results of the pedestrian simulation models.

3.5.6 Findings

The model simulations illustrate that significant sidewalk congestion occurs when the volume density LOS of C is exceeded. The locations modeled were walkway areas that were observed on May 26, 2012, to have significant pedestrian volumes. In these locations, the addition of non-permanent obstructions was clearly identified with decreases in LOS and increases in duration of walkway LOS impacts. The model results support the need to reduce the presence of non-permanent obstructions for the areas evaluated by the models, for sidewalks and street crossings, as well as on pedestrian bridges and at bus stops.

Model 1 – Pedestrian Bridge

According to the modeling analysis of the pedestrian bridge, the full width of the bridge is required to provide the best LOS for the observed pedestrian volumes. Based on the randomness of pedestrian flows and densities, LOS C was exceeded for 36% of the modeled time period from 3:00 PM to 12:00 AM. With the introduction of non-permanent obstructions on the sides of the pedestrian bridge, the effective walkway width (W_E) was reduced and LOS deteriorated. The final scenario including a non-permanent obstruction in the middle of the pedestrian bridge had the greatest impact due to the effective walkway width (W_E) being further reduced. It is evident from the pedestrian bridge model that the introduction of obstructions to the walkway cause a decrease in LOS as less walkway width (W) is available for pedestrian travel.

Model 2 – Sidewalk

The pedestrian simulation model of the constrained sidewalk area included alcoves with non-permanent obstructions. The model demonstrates that the presence of non-permanent obstructions in the alcove areas along the walkway do not impact the pedestrian flow or cause a deterioration of LOS. However, an obstruction along the side of the walkway did significantly affect the LOS of the walkway for the observed pedestrian volumes.

Model 3 – Sidewalk and Bus Stop

Due to the activities of bus stops with their associated queuing areas, walking congestion can occur around bus boarding and alighting. The introduction of non-permanent obstructions in proximity to the bus loading area within the model showed increases in congestion and a deterioration of LOS to LOS E for 56% of the model time (3:00 PM – 12:00 AM) to exceeding LOS E for 100% of the model time.

Model 4 – Signalized Intersection

For the observed pedestrian volumes, with or without non-permanent obstructions, the pedestrian corner queuing areas at the modeled signalized intersection experience high pedestrian densities and resulting LOS of E and F. Based upon these findings, these areas should be kept clear of unnecessary obstructions, to provide the maximum queuing space for pedestrians.

Figure 3.66 – Model 1 – Pedestrian Bridge Model Screenshot



Legend:
LOS A-C
LOS D
LOS E-F

Figure 3.67 – Model 2 – Sidewalk Model Screenshot



Figure 3.68 – Model 3 – Sidewalk and Bus Stop Model Screenshot

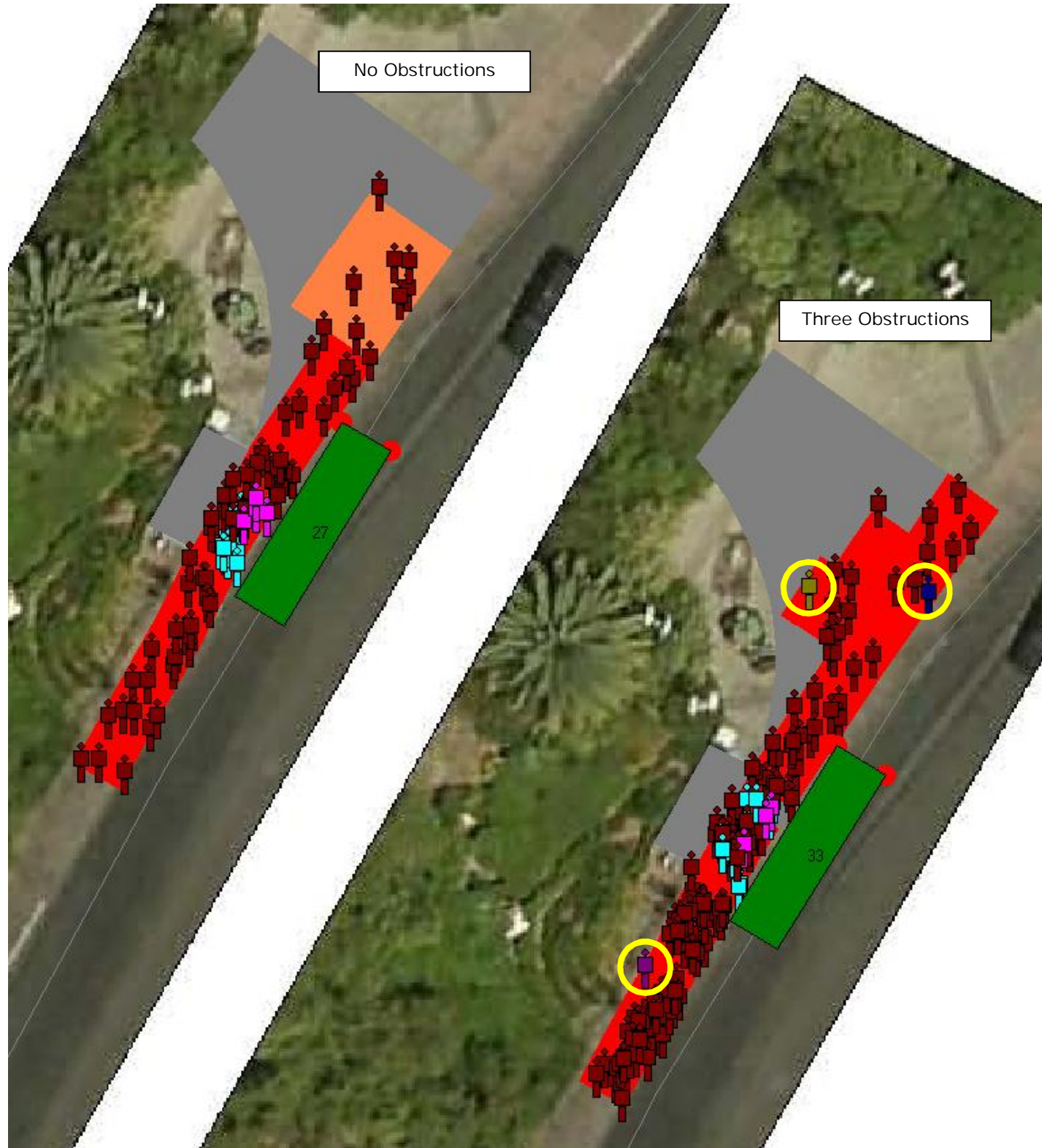

Figure 3.69 – Model 4 – Queuing at Signalized Intersection Model Screenshot



Figure 3.70 – Model 1 – Pedestrian Bridge Model Output

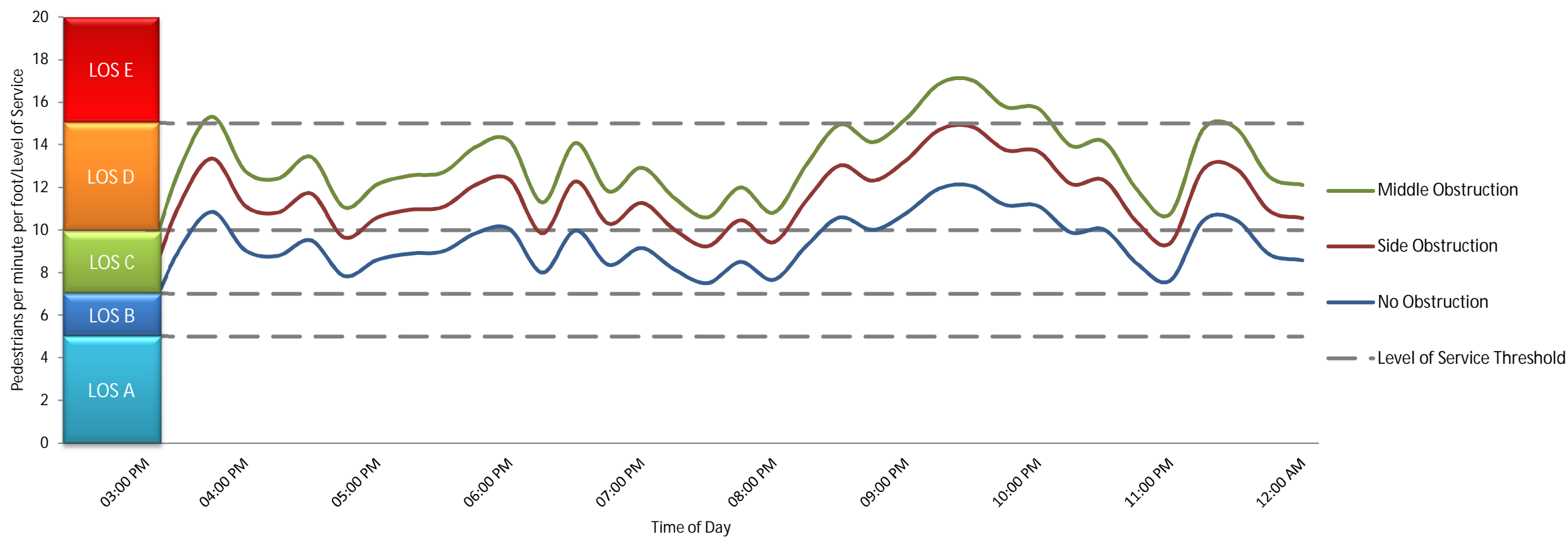

Figure 3.71 – Model 2 – Sidewalk Model Output

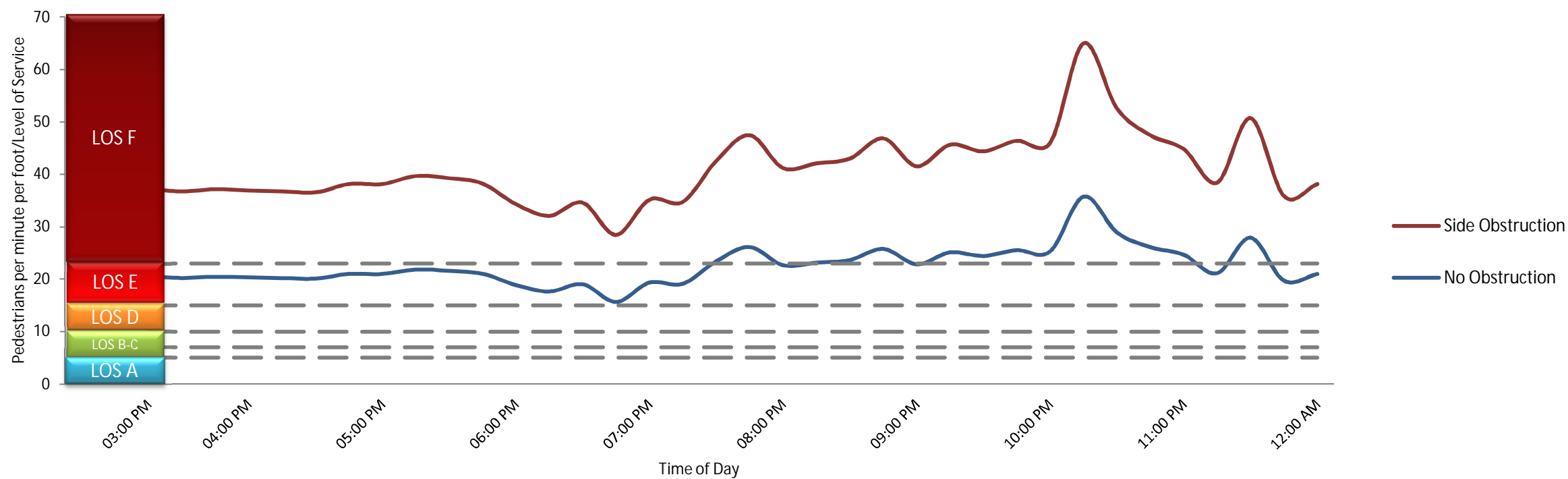
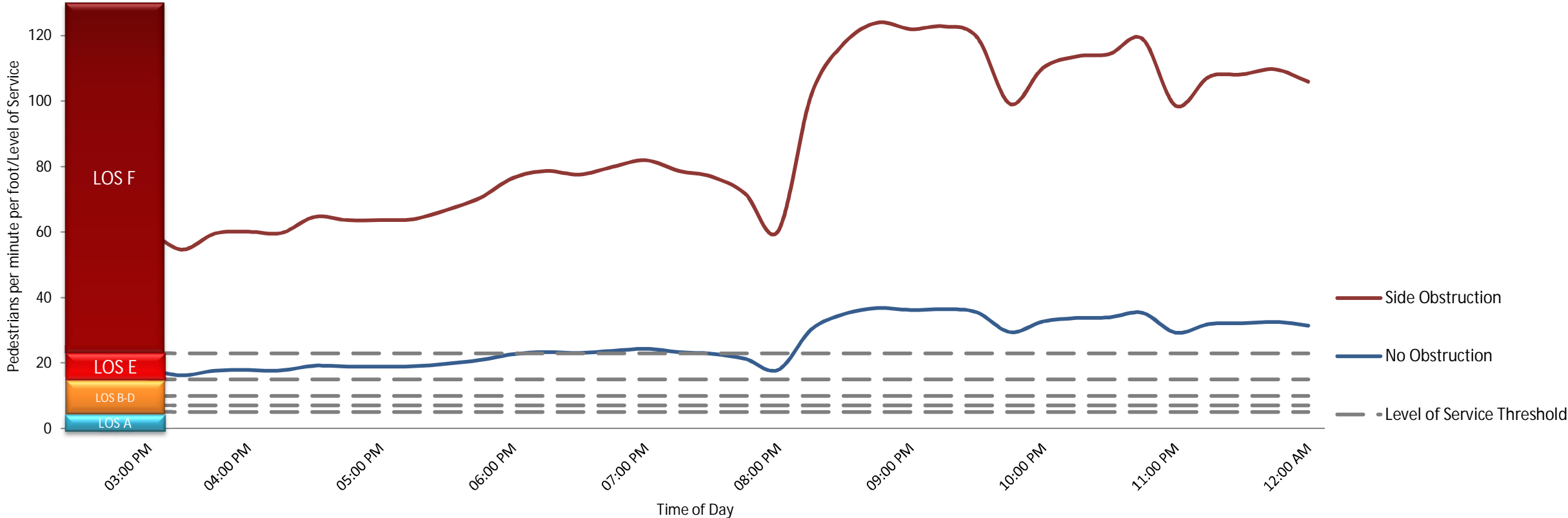

Figure 3.72 – Model 3 – Sidewalk and Bus Stop Model Output



3.6 Walkway Segment Time of Day Restriction Analysis

Based on observed pedestrian volumes, level of service, walkway conditions and pedestrian safety concerns, the locations shown in Figure 3.73 within the study corridor, have been identified as walkway segments in which non-permanent obstruction restrictions should be considered during specific days of the week and times of the day.

To identify the time of day, day of week, and month of year that certain walkway segments within the study corridor should be considered for restriction of non-permanent obstructions, the following steps were taken:

- Effective walkway widths along the entire length of the study corridor were grouped into segments with similar effective walkway widths (see Figure 2.1).
- Pedestrian volumes from all of the count locations were evaluated to identify a common daily peak pedestrian volume time period. This daily time period was found to occur between 9:00 AM and 11:00 AM.
- Pedestrian volumes for the common peak period were assigned to each segment of the study corridor to calculate a peak period LOS using 2010 HCM procedures (see Figure 3.74).
- The LOS analysis resulted in 17 walkway segments that were found to exceed LOS C on the Holiday and/or Typical Saturday (May 26 and/or June 16, 2012) labeled R1 to R17 from south to north (see Figure 3.73 for segment location) (see Figure 3.75 through Figure 3.91 for volume data at each location that exceeded LOS C for more than four hours).
- Figure 3.75 through Figure 3.87 show the volume distribution data at each location for the lowest pedestrian volume day of week where LOS C was exceeded for four hours on the holiday weekend. Similarly, Figure 3.88 through Figure 3.91 display volume distribution data for walkway segments during the typical weekend that exceeded LOS C for more than four hours.
- Walkway segments that resulted in a LOS C were considered further and analyzed to determine if the addition of an obstruction would result in the LOS deteriorating to D or greater. A reduction of the effective walkway width (W_E) of 2.25 feet associated with the obstruction of one person standing on the side of the walkway was applied for the analysis.
- The walkway segments were separated into three categories:
 - Walkways with no pedestrian containment
 - Walkways with pedestrian containment
 - Pedestrian bridges
- The Saturday count data was adjusted using the week-long data and the year-long data, provided by Caesars International, to determine day of week and month of year adjustment factors. The adjustment factors were used to determine time periods when walkway segments were estimated to exceed LOS C for days other than those counted on Saturday May 26 and June 16, 2012.

Table 3.41 summarizes the results of the analysis for possible time of day, day of week and month of year restrictions based solely on pedestrian volumes and walkway widths. Table 3.42 provides a summary of the analysis for possible non-permanent obstruction restrictions including an effective walkway width (W_E) reduction of 2.25 feet for an obstruction (note that the length of time for many areas increase and additional days of week are included).



SEE BELOW LEFT



SEE ABOVE RIGHT

Legend

 LOS > C

 Segment Reference Number

**WALKWAY SEGMENTS THAT EXCEED LEVEL OF SERVICE (LOS) C
AVERAGE EFFECTIVE WALKWAY WIDTH AND AVERAGE 15 MIN. VOLUME
9 P.M. - 11 P.M.**

FIGURE 3.73 116

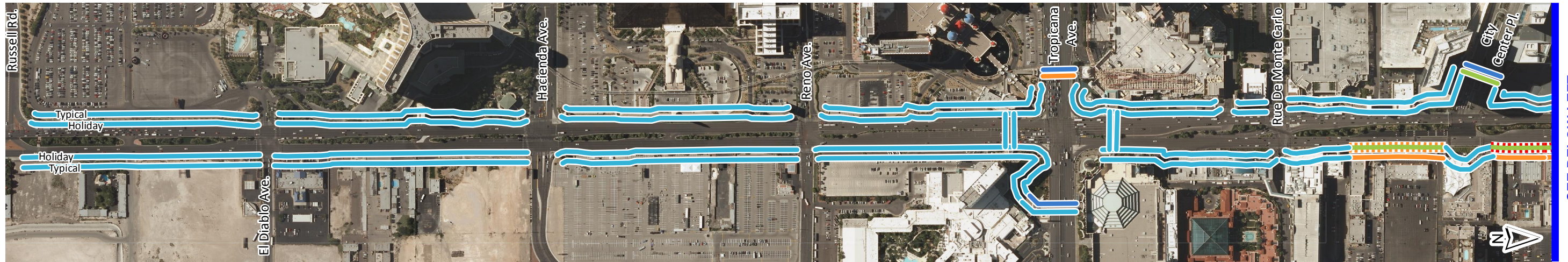

SEE BELOW LEFT

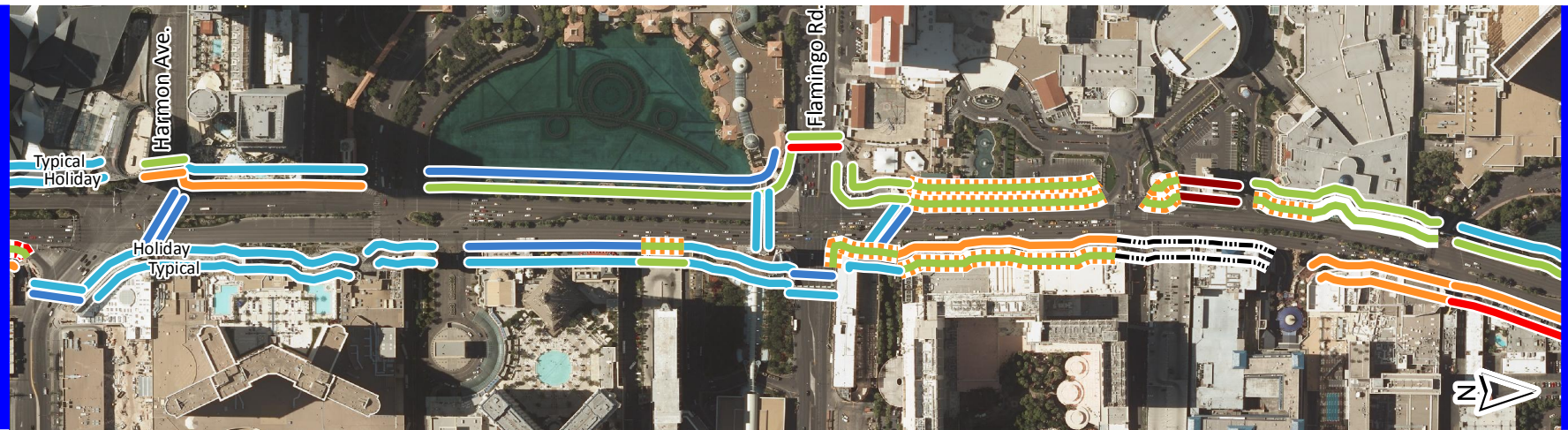

SEE ABOVE RIGHT

SEE RIGHT

SEE LEFT

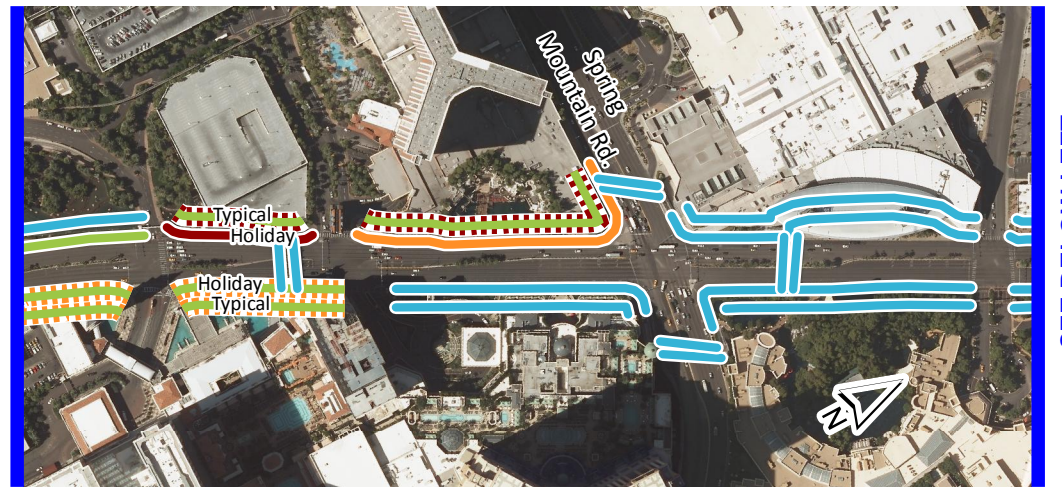

SEE BELOW LEFT

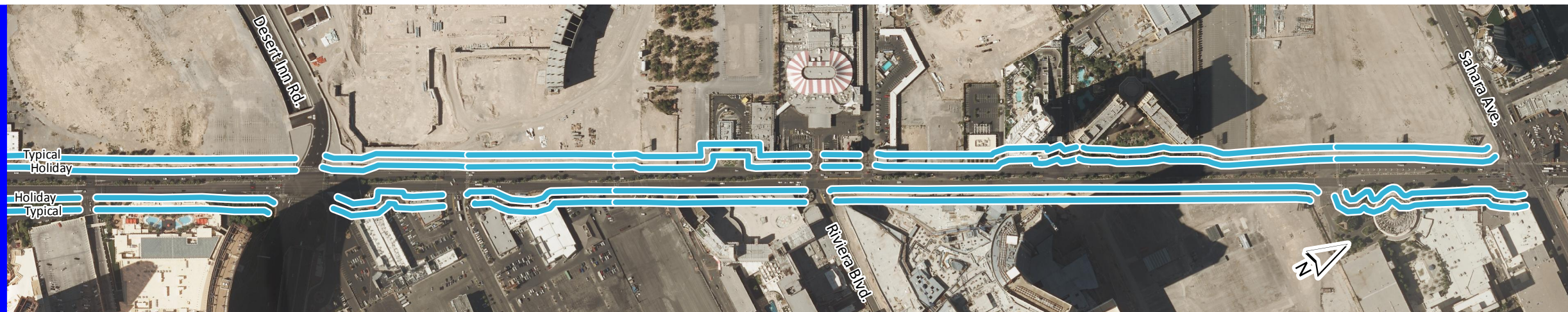

SEE ABOVE RIGHT

**LEVEL OF SERVICE (LOS)
AVERAGE EFFECTIVE WALKWAY WIDTH (W_e) AND AVERAGE 15 MIN. VOLUME
9 P.M. - 11 P.M.**

Legend

Level of Service (LOS)

- A
- B
- C to D*
- C to E*
- C to F*
- C
- D
- E
- F
- Under Construction

* C to "X" with 2.25 ft W_e reduction for an obstruction

FIGURE 3.74 117

Harley Davidson Cafe (R3)
 Holiday Saturday
 Effective Walkway Width (W_E) = 6 feet

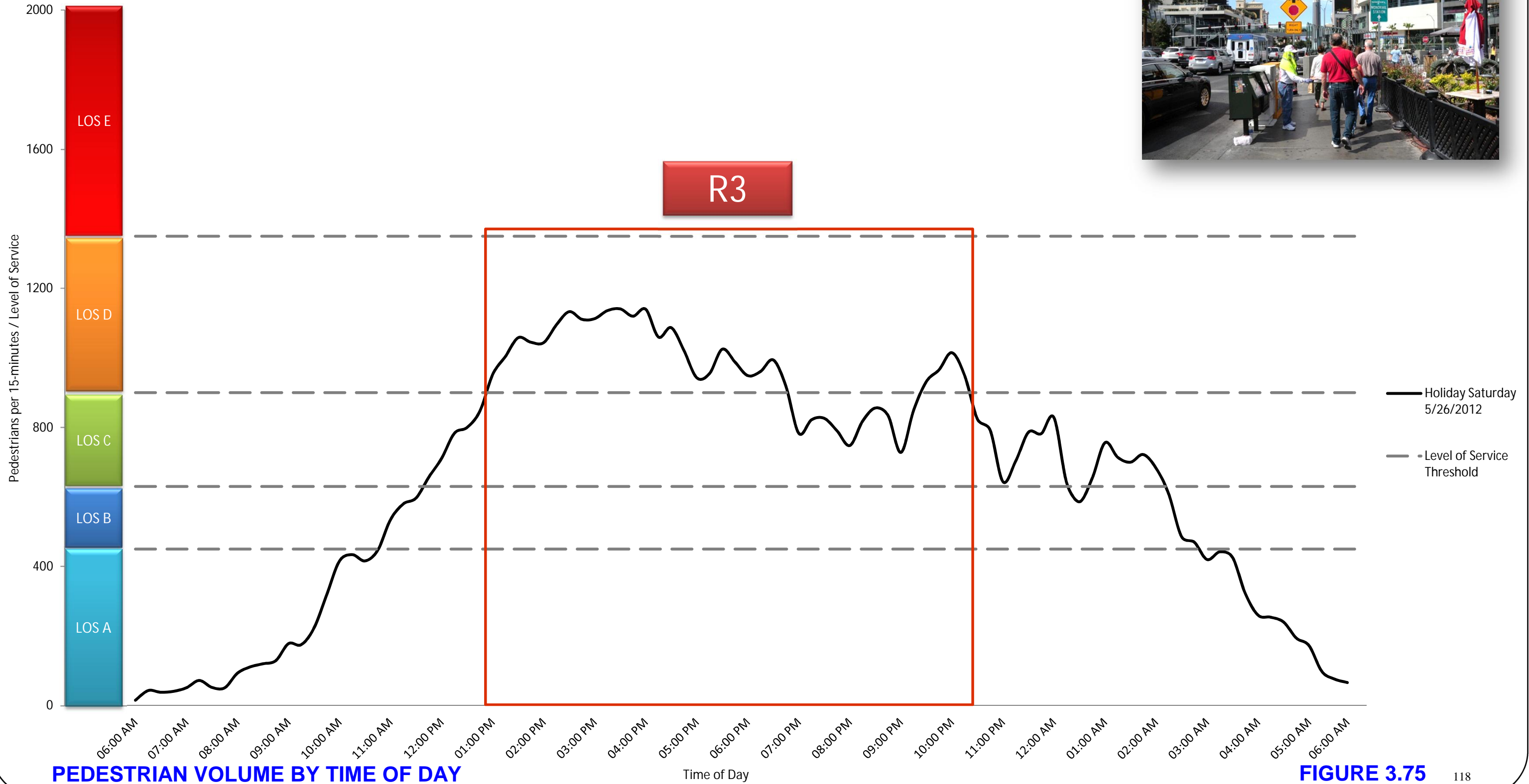

PEDESTRIAN VOLUME BY TIME OF DAY

Harmon Avenue West Pedestrian Bridge (R4)
 Holiday Saturday
 Effective Walkway Width (W_E) = 12.5 feet

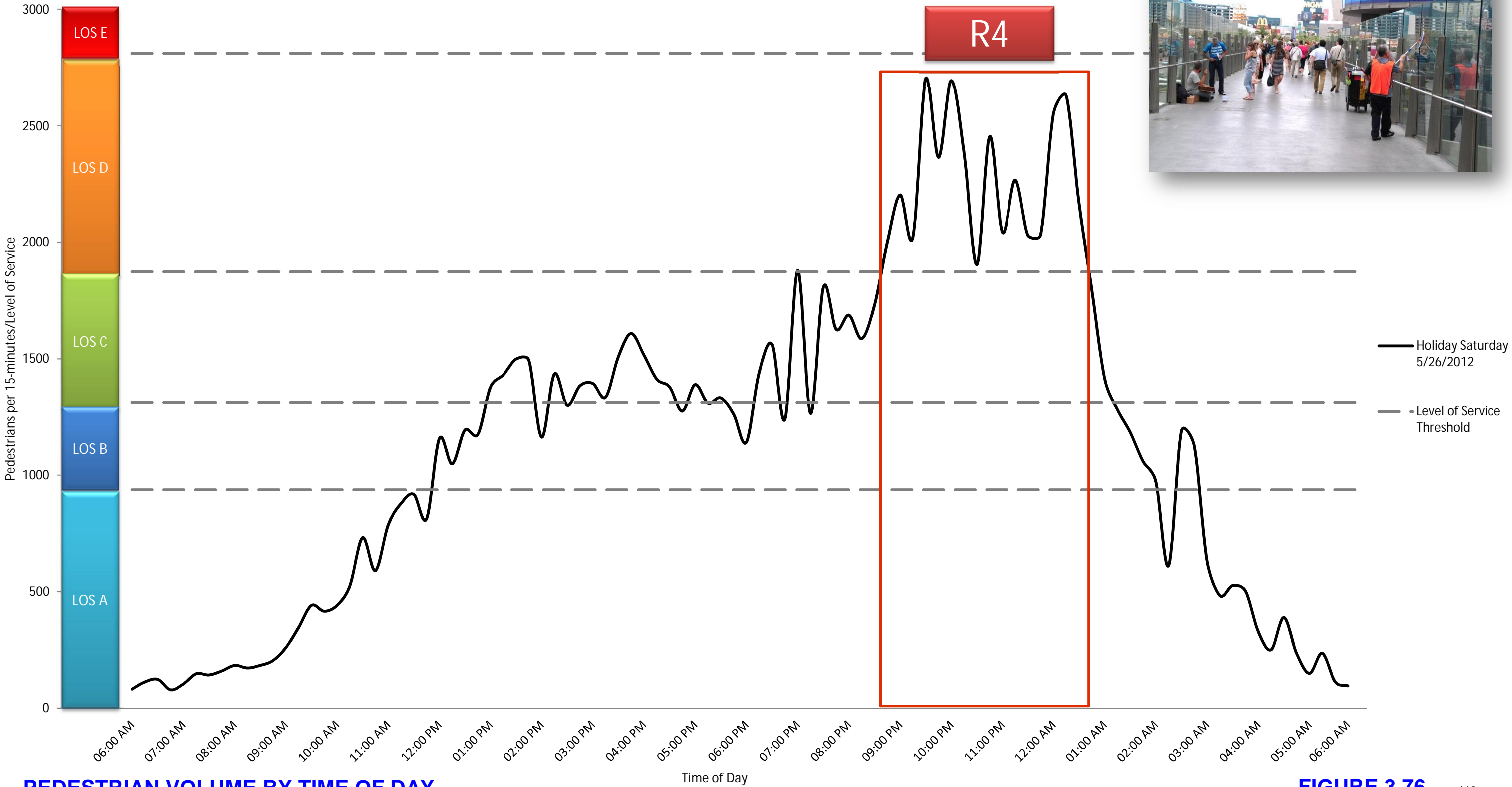

PEDESTRIAN VOLUME BY TIME OF DAY

Cosmopolitan Hotel/Casino (R5)
 Holiday Friday
 Effective Walkway Width (W_E) = 12 feet

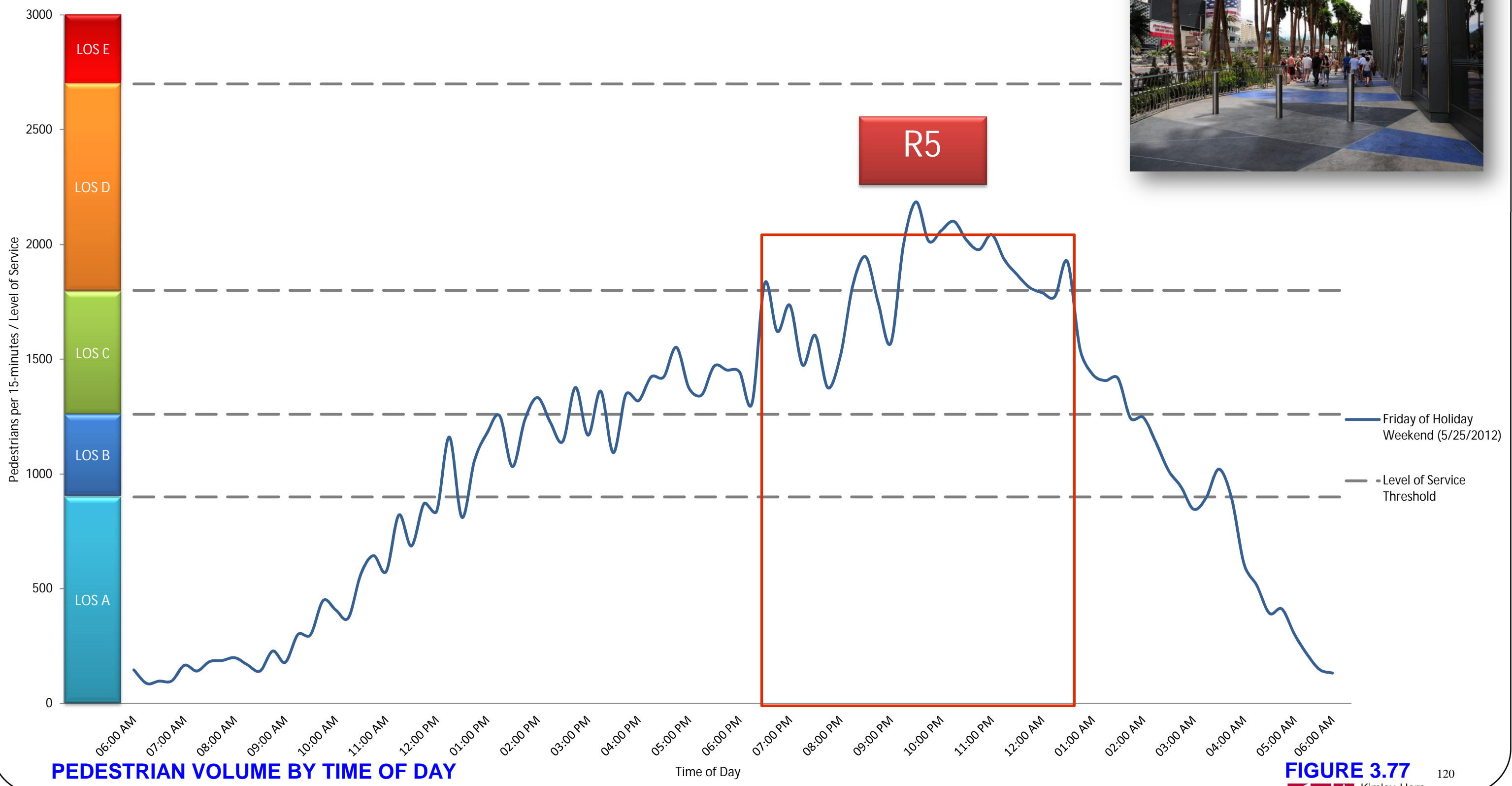

PEDESTRIAN VOLUME BY TIME OF DAY

FIGURE 3.77 120
 Kimley-Horn and Associates, Inc.

Bally's Hotel/Casino South (R6)
 Holiday Saturday
 Effective Walkway Width (W_E) = 11 feet

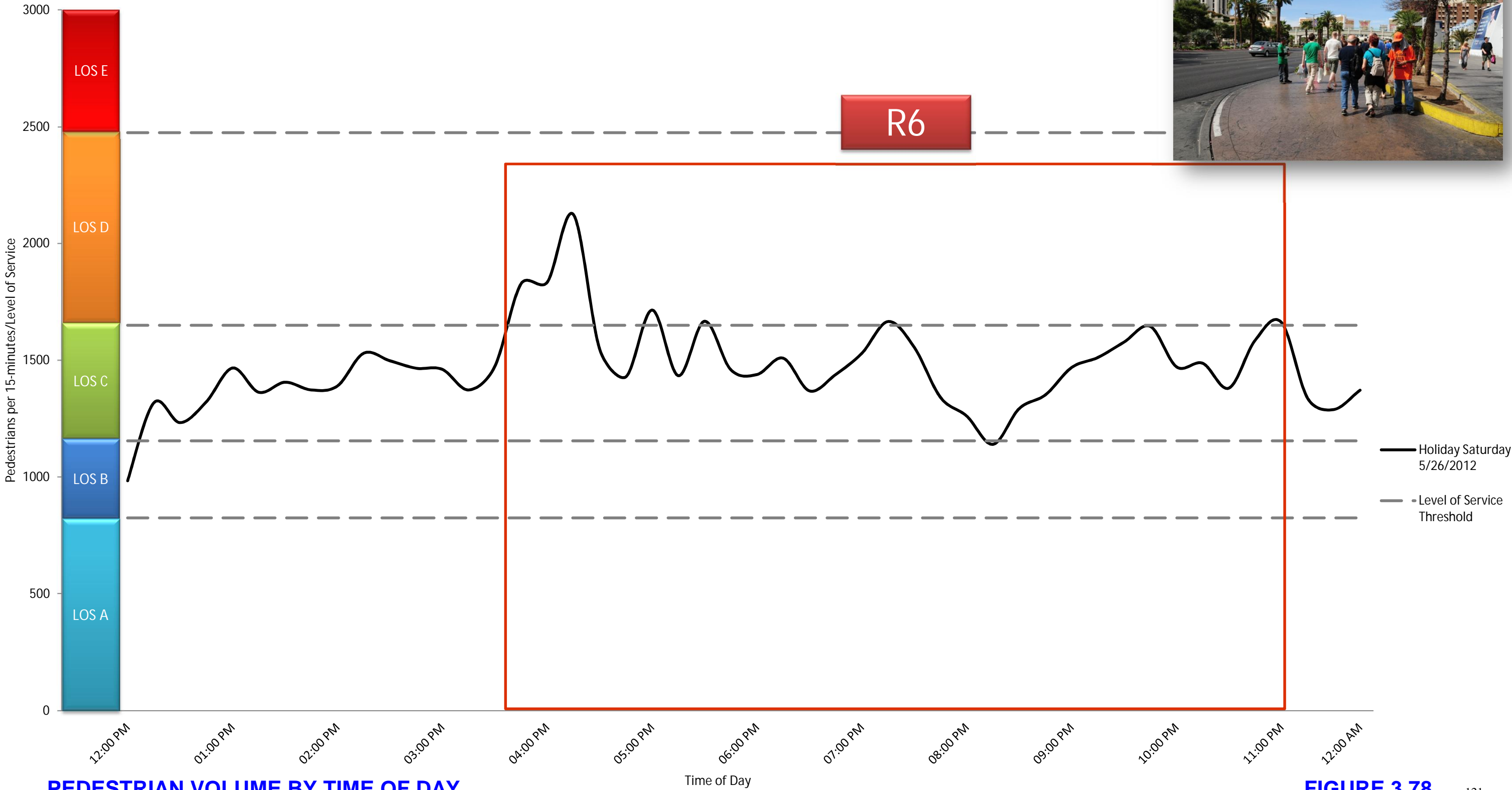

PEDESTRIAN VOLUME BY TIME OF DAY

Flamingo Road West Pedestrian Bridge (R7)
 Holiday Saturday
 Effective Walkway Width (W_E) = 12 feet

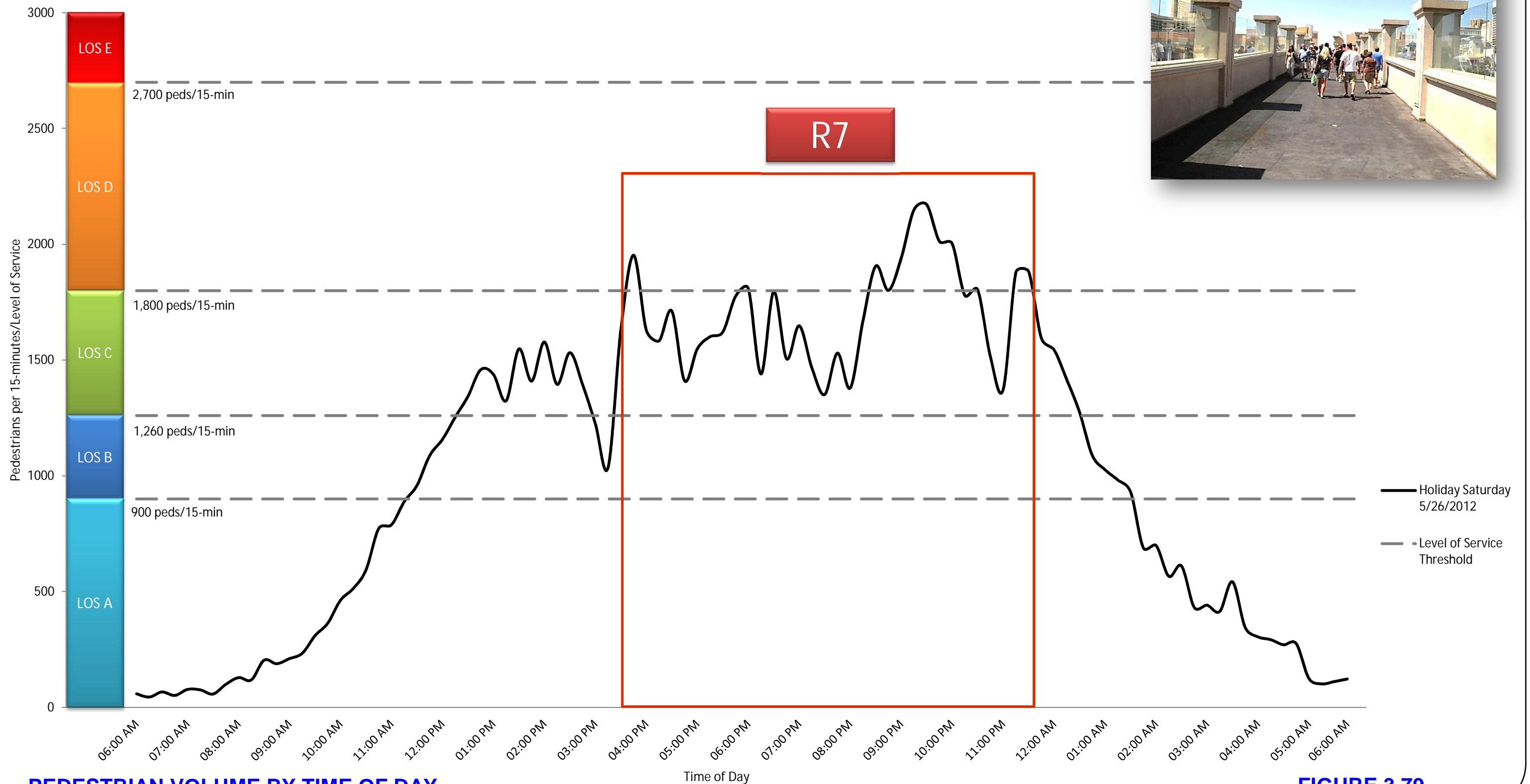

PEDESTRIAN VOLUME BY TIME OF DAY

Flamingo Hotel/Casino (R9)
 Holiday Friday
 Effective Walkway Width (W_E) = 7 feet

Walkway Picture

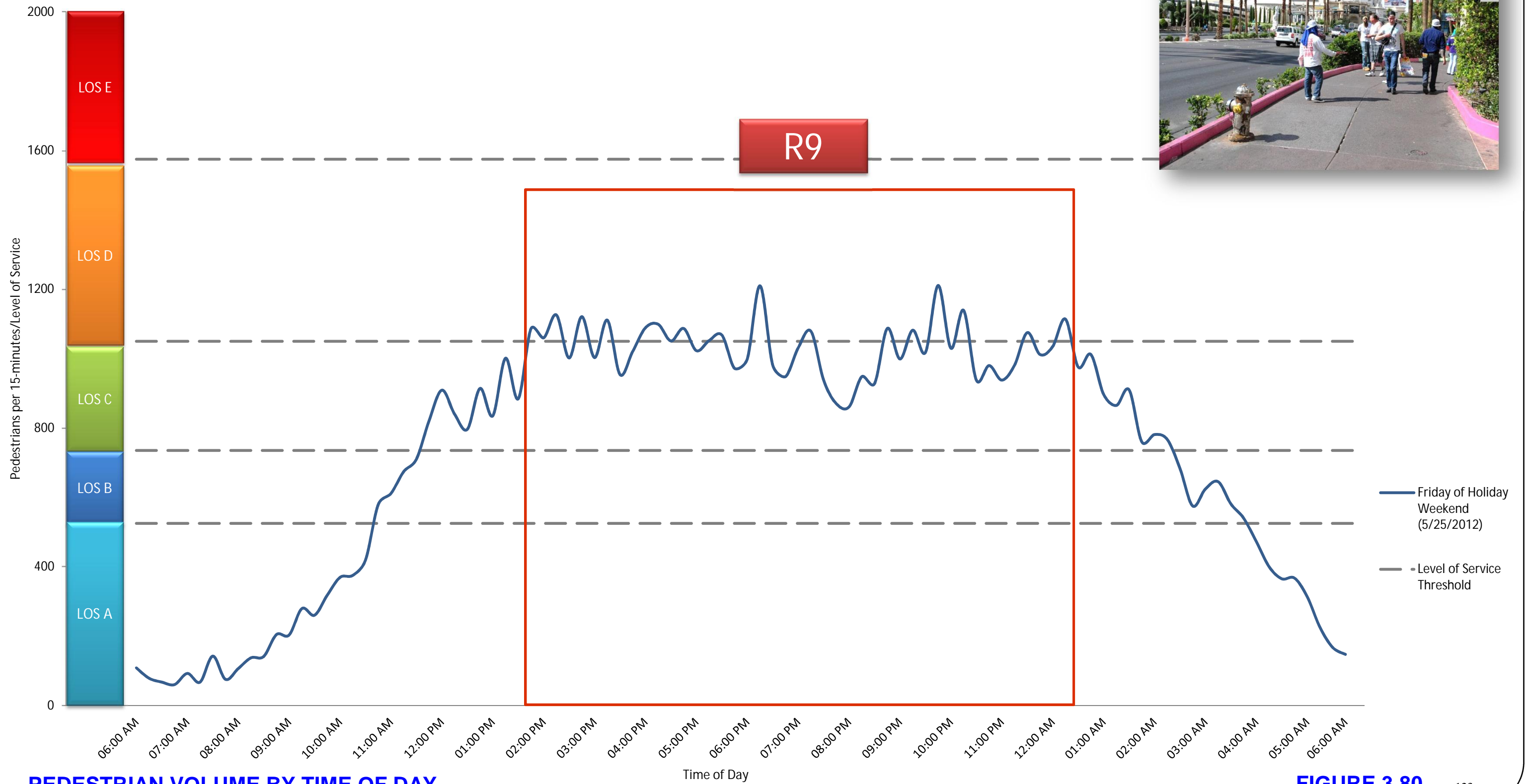

PEDESTRIAN VOLUME BY TIME OF DAY

Caesars Palace Coliseum (R10)
 Holiday Monday
 Effective Walkway Width (W_E) = 4 feet

Walkway Picture

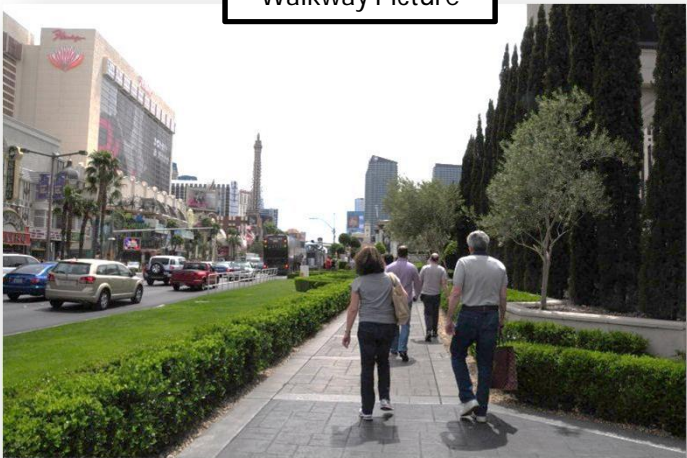

R10

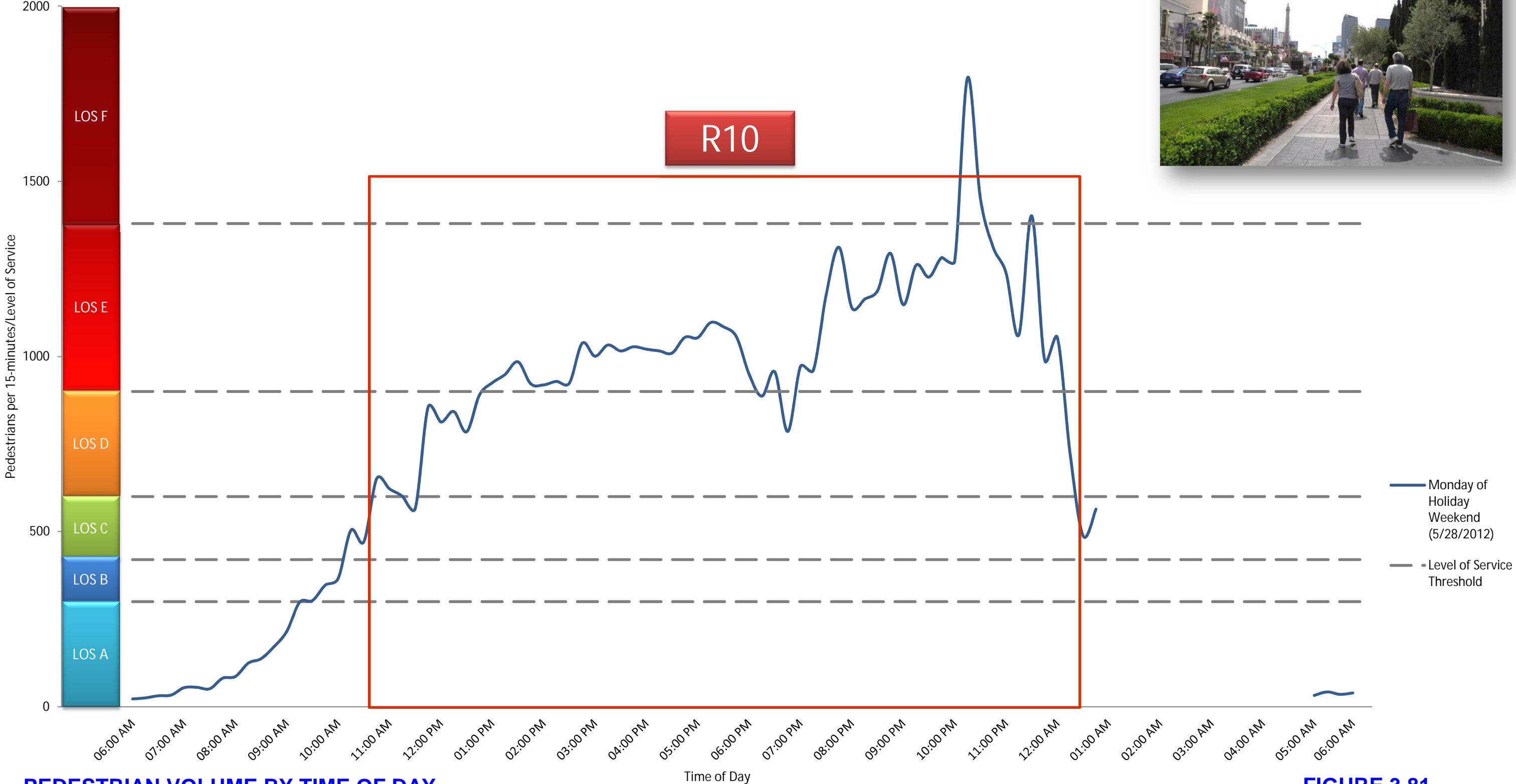

PEDESTRIAN VOLUME BY TIME OF DAY

Forum Shops (R11)
 Holiday Saturday
 Effective Walkway Width (W_E) = 13 feet

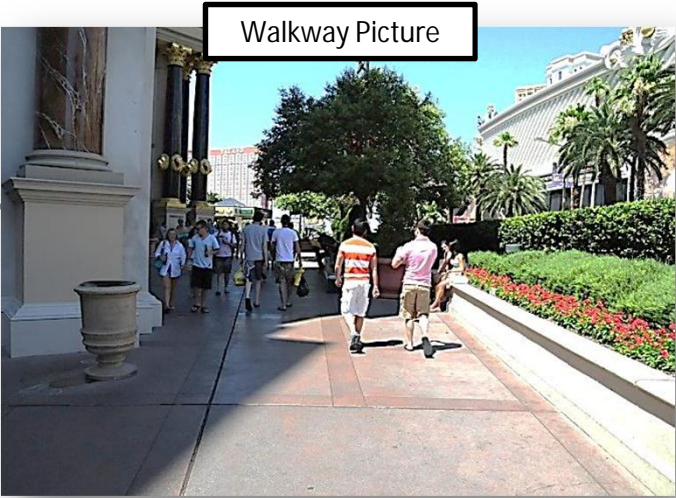
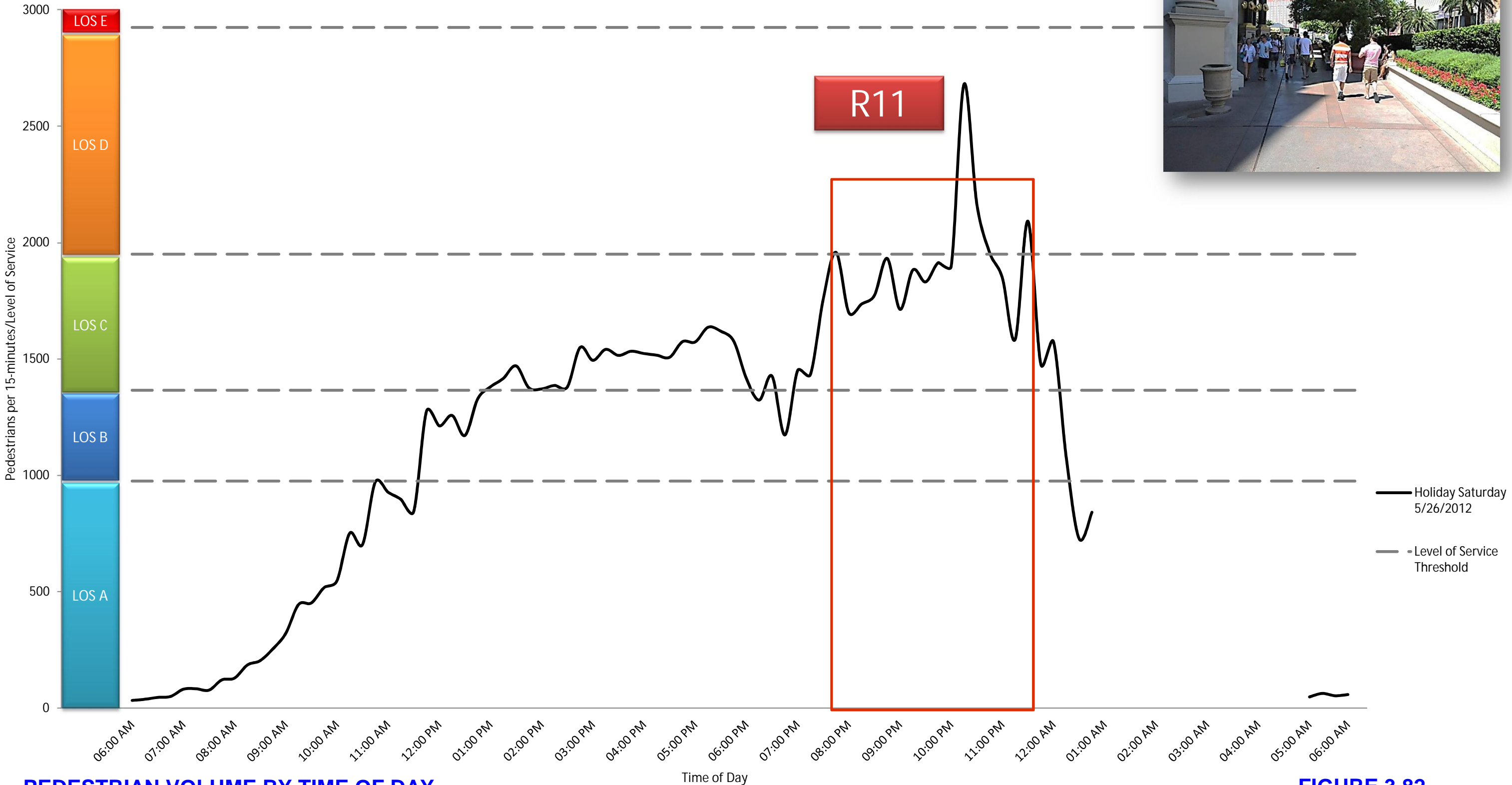

PEDESTRIAN VOLUME BY TIME OF DAY

FIGURE 3.82 125
 Kimley-Horn and Associates, Inc.

Harrah's Hotel/Casino (R12)
 Holiday Saturday
 Effective Walkway Width (W_E) = 6.5 feet

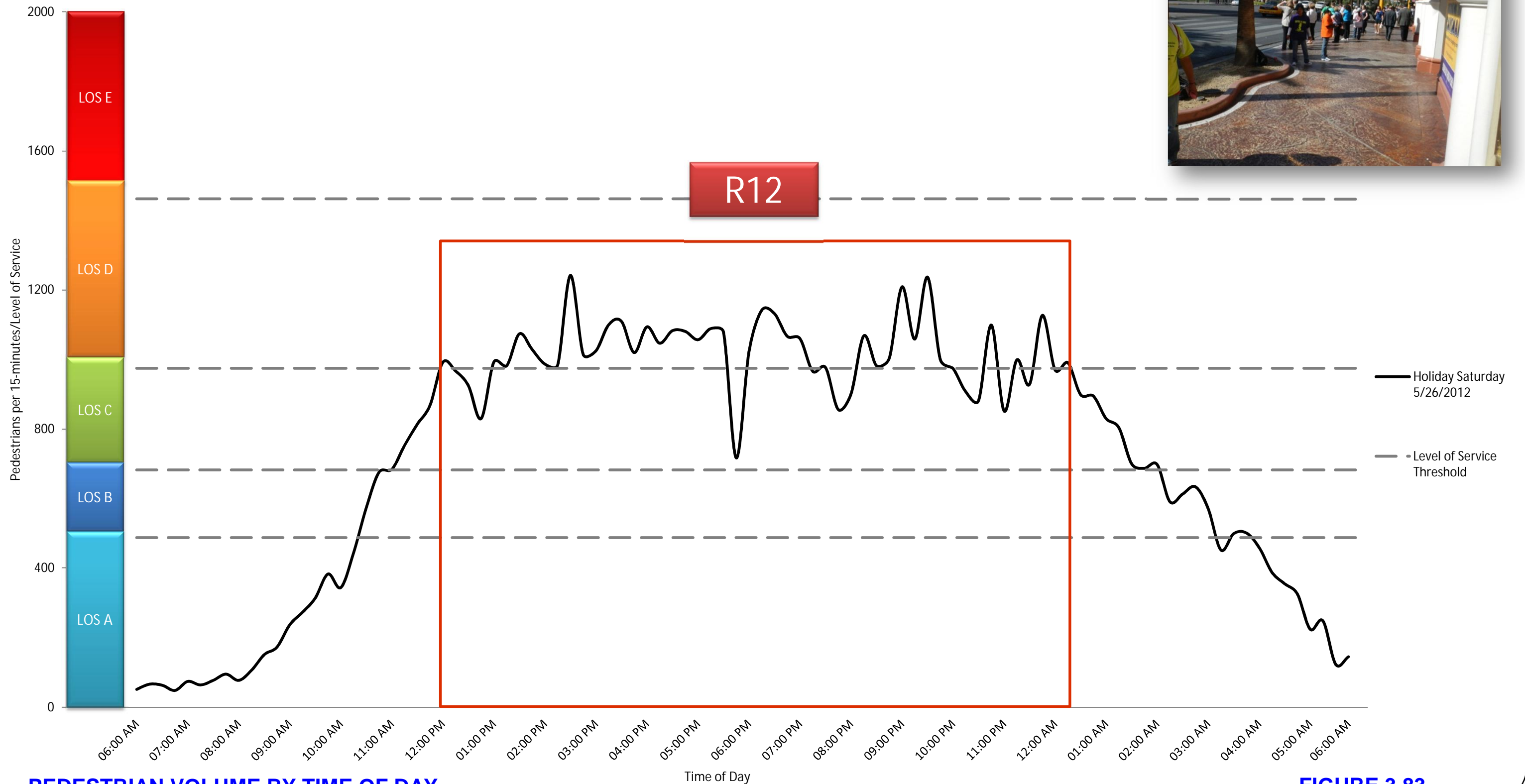

PEDESTRIAN VOLUME BY TIME OF DAY

Casino Royale Hotel/Casino (R13)
 Holiday Friday
 Effective Walkway Width (W_E) = 6 feet



R13

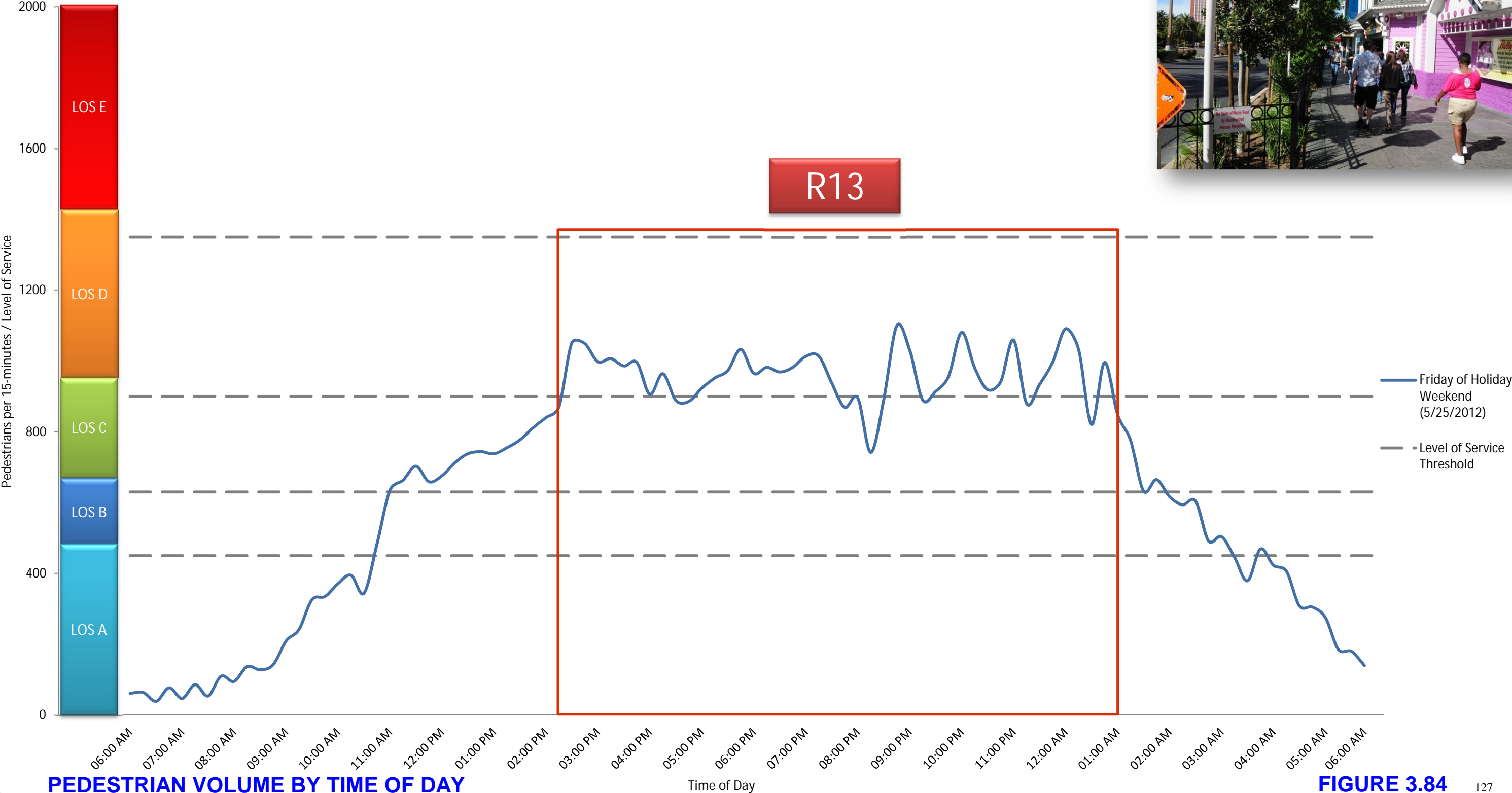

PEDESTRIAN VOLUME BY TIME OF DAY

Venetian Hotel/Casino North (R15)
 Holiday Saturday
 Effective Walkway Width (W_E) = 7 feet

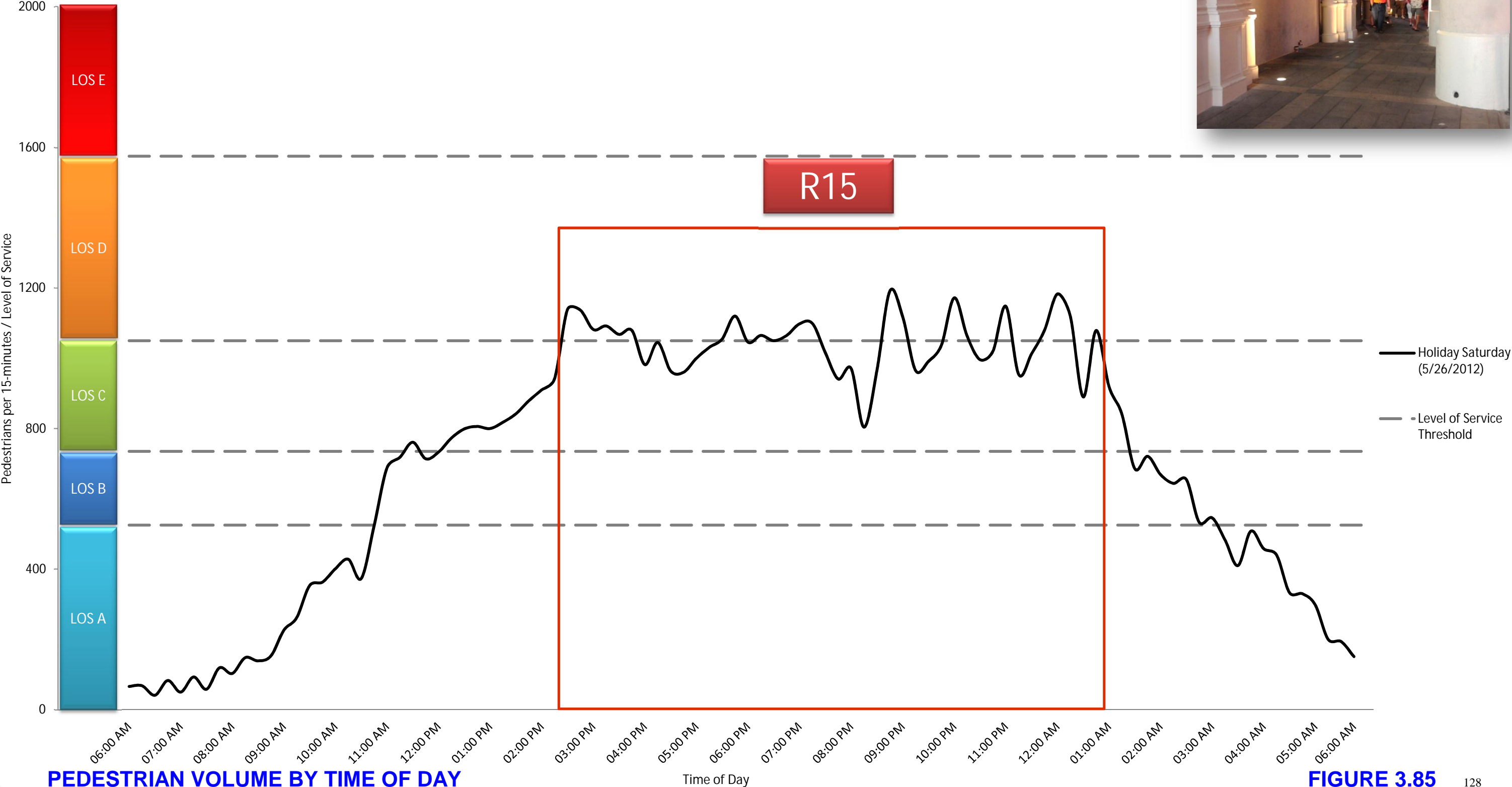

PEDESTRIAN VOLUME BY TIME OF DAY

Treasure Island Bus Stop (R16)
 Holiday Monday
 Effective Walkway Width (W_E) = 3 feet

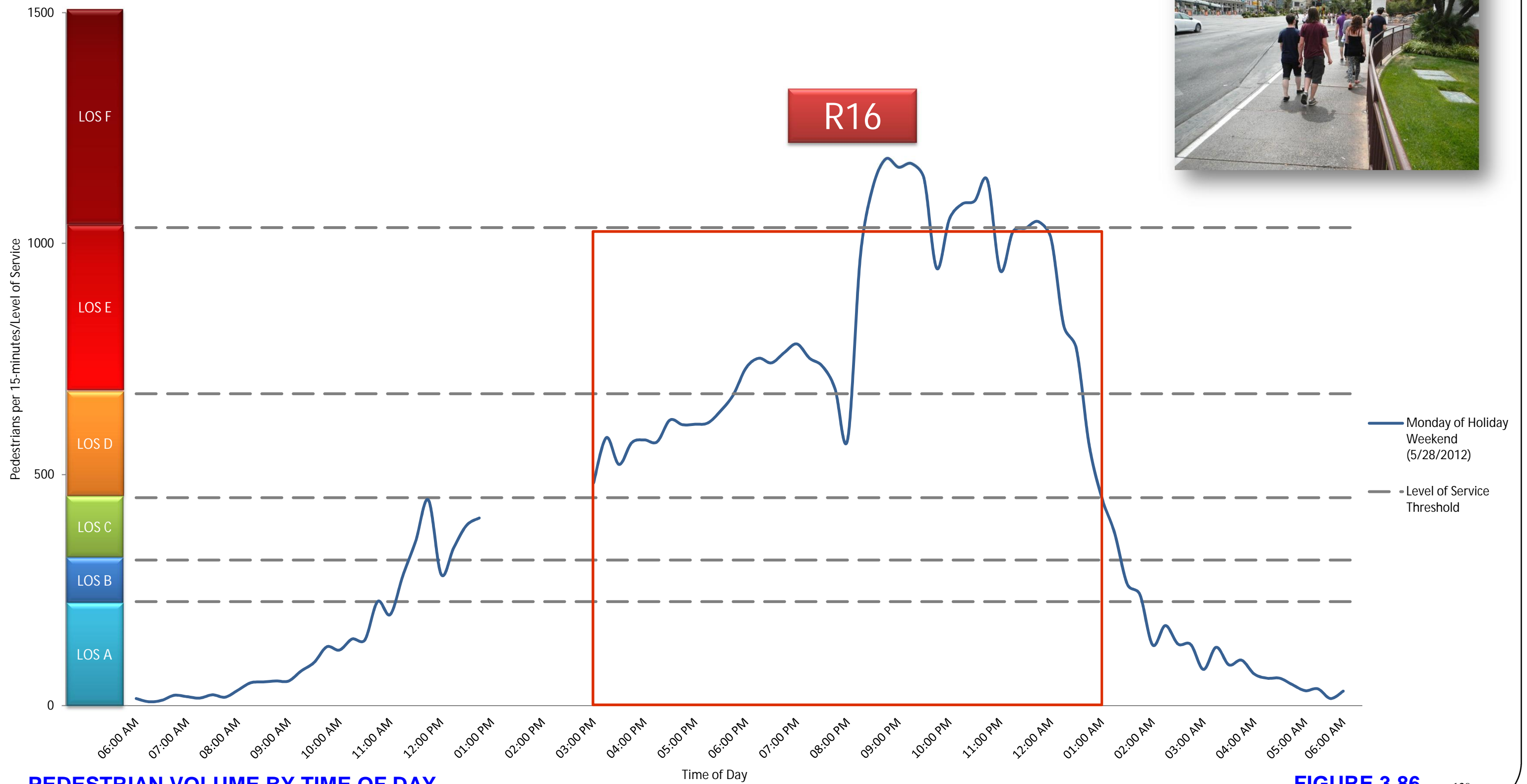

PEDESTRIAN VOLUME BY TIME OF DAY

Treasure Island Hotel/Casino (R17)
 Holiday Saturday
 Effective Walkway Width (W_E) = 1.7 feet

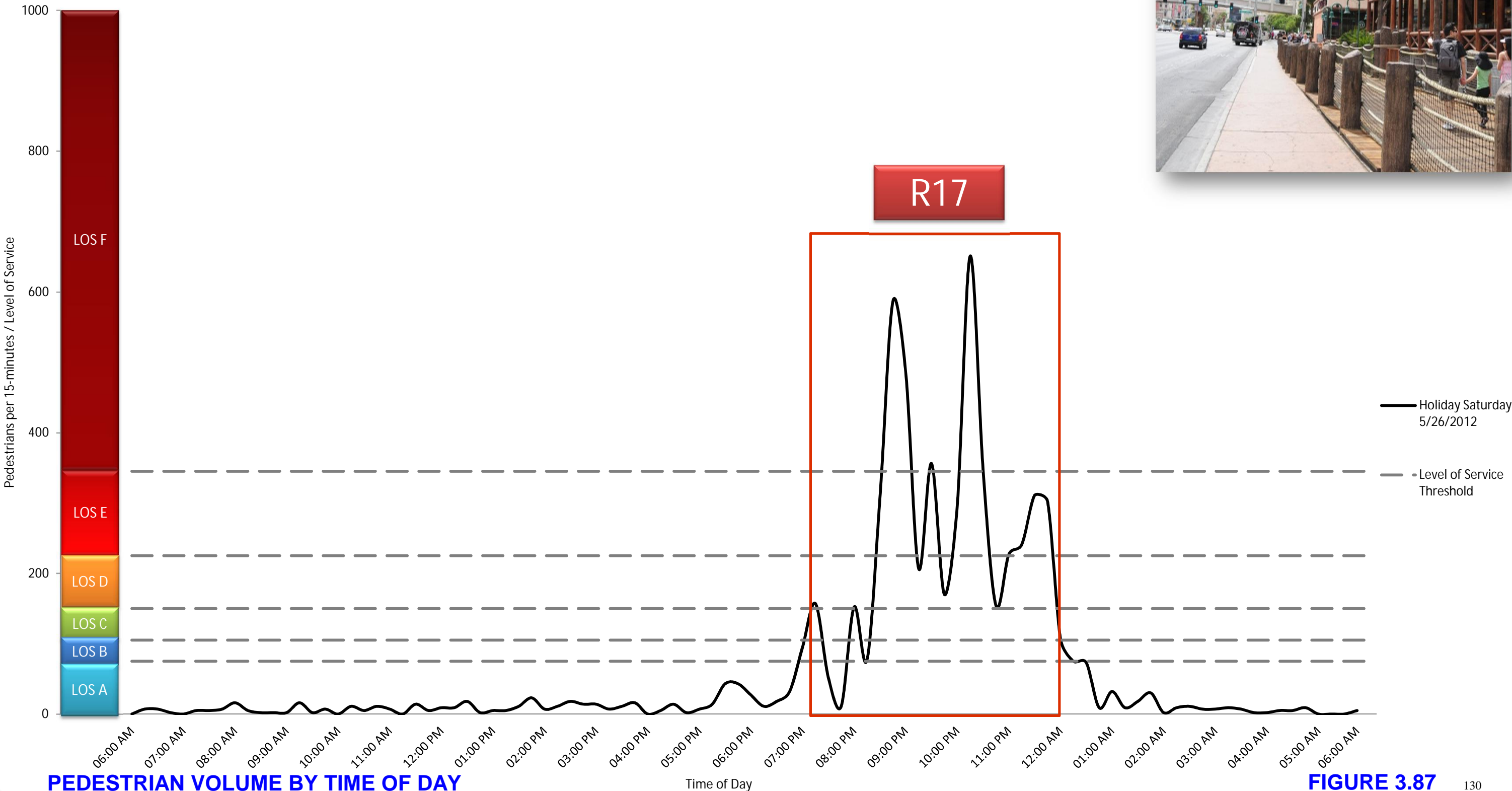

PEDESTRIAN VOLUME BY TIME OF DAY

FIGURE 3.87 130
 Kimley-Horn and Associates, Inc.

Harley Davidson Cafe (R3)
 Typical Friday
 Effective Walkway Width (W_E) = 6 feet

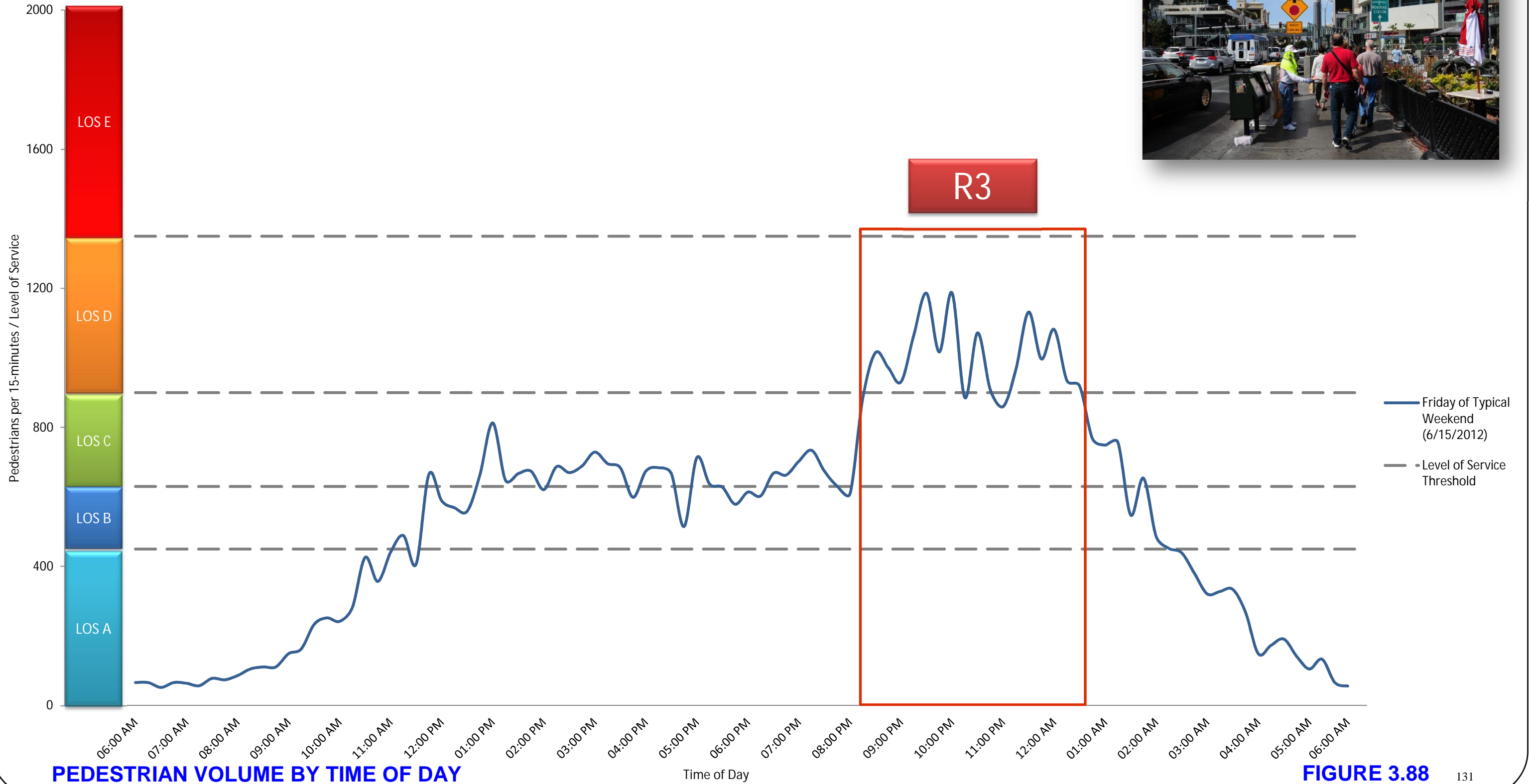

PEDESTRIAN VOLUME BY TIME OF DAY

Caesar's Palace Coliseum (R10)
 Typical Weekday
 Effective Walkway Width (W_E) = 4 feet

Walkway Picture

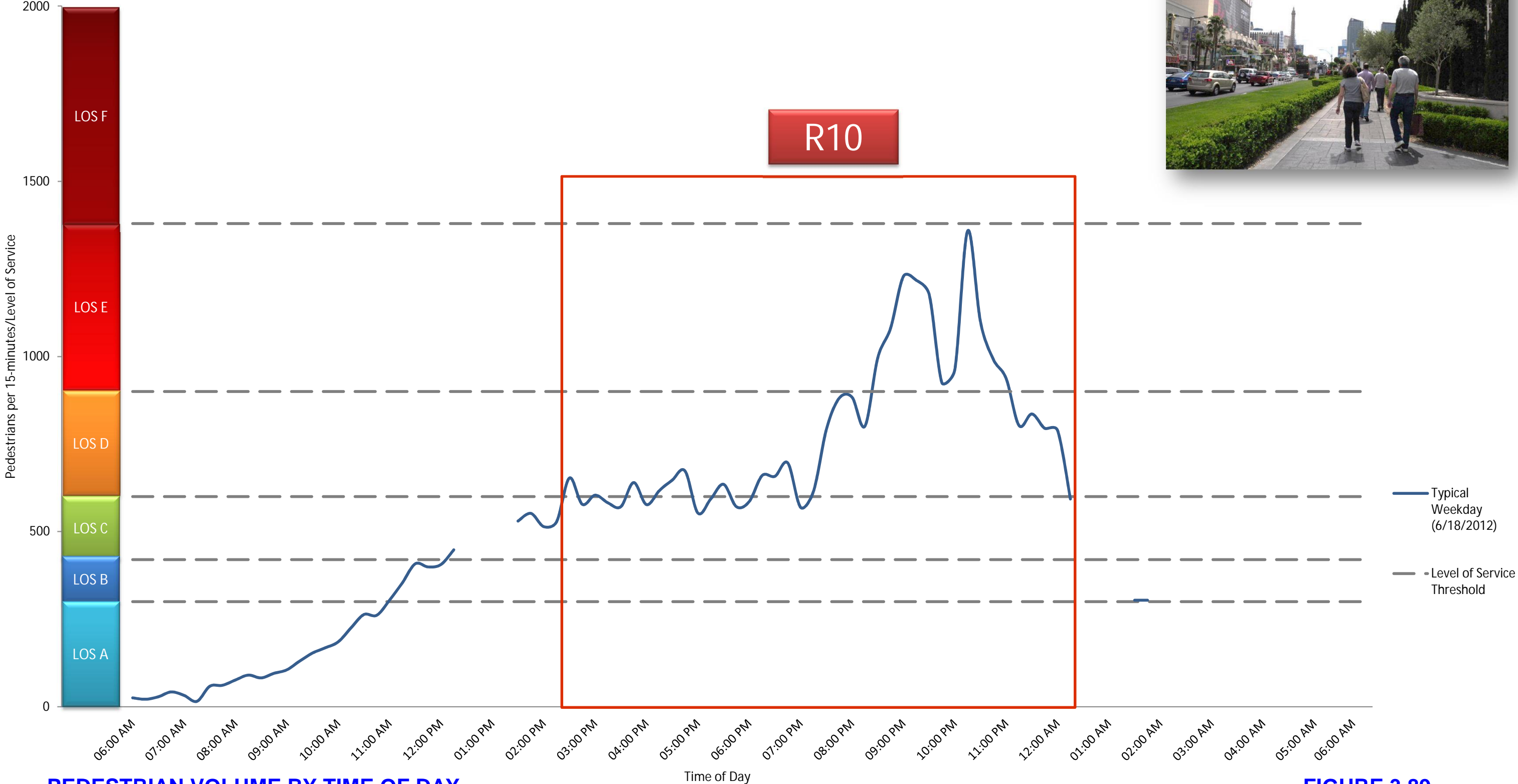
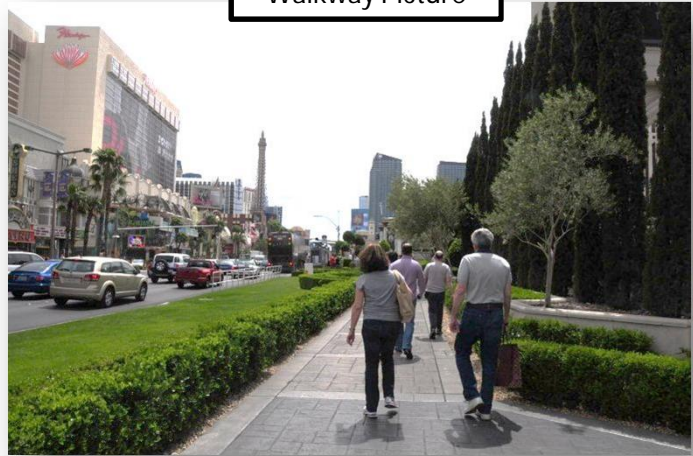

PEDESTRIAN VOLUME BY TIME OF DAY

Casino Royale Hotel/Casino (R13)
 Typical Friday
 Effective Walkway Width (W_E) = 6 feet

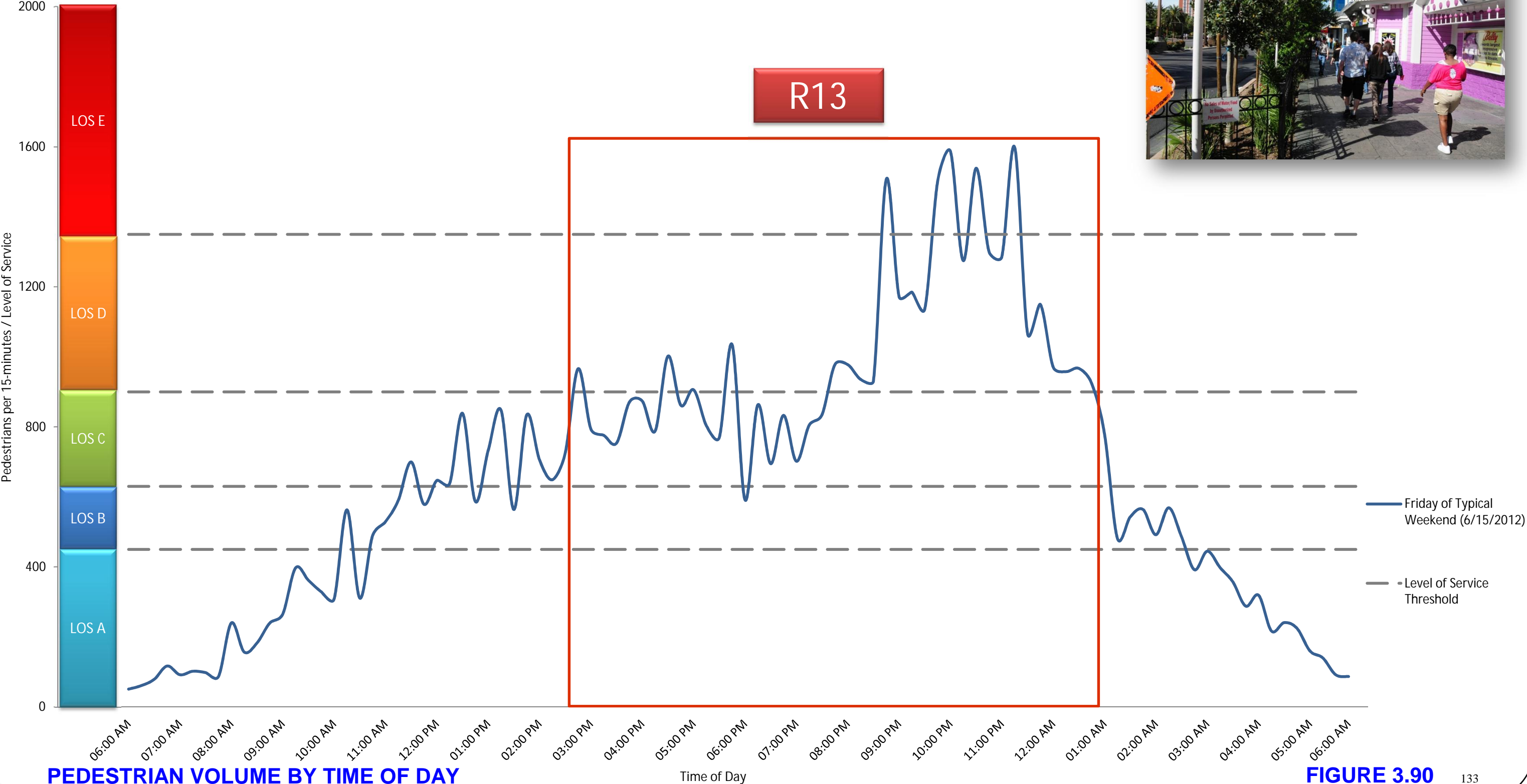

PEDESTRIAN VOLUME BY TIME OF DAY

Treasure Island Bus Stop (R16)
 Typical Friday
 Effective Walkway Width (W_E) = 3 feet

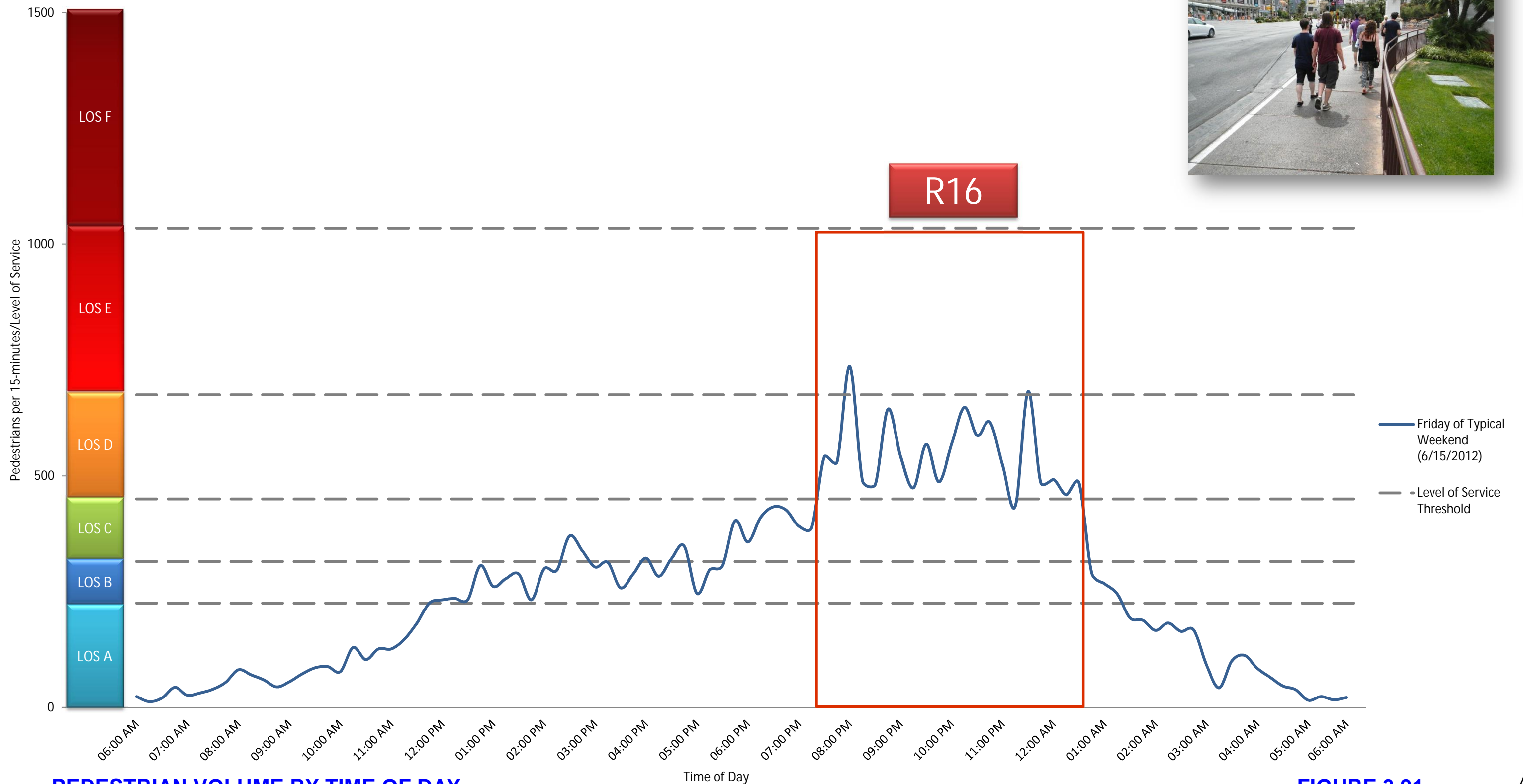

PEDESTRIAN VOLUME BY TIME OF DAY

Table 3.41 – Walkways which Exceed LOS C - Time of Day, Day of Week, and Month of Year

Holiday Weekend - Existing Walkway

	Location ID	Segment Name	Friday		Saturday		Sunday		Monday		Feb-Nov-Dec			Shortest Period of Time Common to All Days (Minimum of 4 hours)
			LOS	Hours of Friday LOS	LOS	Hours of Sat LOS	LOS	Hours of Sunday LOS	LOS	Hours of Monday LOS	Jan	Nov	Dec	
Walkways with No Pedestrian Containment	R2	The Plaza	-	-	D	1:30PM - 5:00PM	D	1:30PM - 5:00PM	-	-	-	X	-	
	R3	Harley D	D	2:00PM - 4:30PM	D	1:00PM - 10:30PM	D	1:00PM - 10:30PM	-	-	-	X	-	1:00PM - 10:30PM Sat & Sun
	R6	Bally's S	D	4:00PM - 4:30PM	D	3:30PM - 11:00PM	D	3:30PM - 11:00PM	-	-	-	X	-	3:30PM - 11:00PM Sat & Sun
	R8	Caesars	-	-	D	9:00PM - 11:30PM	D	9:00PM - 11:30PM	-	-	-	X	-	
	R12	Harrah's	-	-	D	12:00PM - 12:30AM	D	12:00PM - 12:30AM	-	-	-	X	-	12:00PM - 12:30PM Sat & Sun
	R16	TI Bus Stop	D/E/F	11:30AM - 1:30AM	D/E/F	11:30AM - 1:30AM	D/E/F	11:30AM - 1:30AM	D/E/F	3:00PM - 1:00AM	X	X	X	3:00AM - 1:00AM Fri, Sat, Sun & Mon
	R17	Treasure Island	D/E/F	8:30PM - 12:00AM	D/E/F	7:30PM - 12:00AM	D/E/F	7:30PM - 12:00AM	D/E/F	8:30PM - 12:00AM	X	X	X	7:30PM - 12:00AM Sat & Sun
Walkways with Containment	R5	Cosmo	D	6:30PM - 12:30AM	D	4:30PM - 1:30AM	D	4:30PM - 1:30AM	-	-	X	X	-	6:30PM - 12:30AM Fri, Sat & Sun
	R9	Flamingo	D	1:30PM - 12:30AM	D	12:00PM - 1:30AM	D	12:00PM - 1:30AM	-	-	-	X	-	1:30PM - 12:30AM Fri, Sat & Sun
	R10	Coliseum	D/E/F	10:00AM - 1:30AM	D/E/F	10:00AM - 1:30AM	D/E/F	10:00AM - 1:30AM	D/E/F	10:30AM - 12:30AM	X	X	X	10:30AM - 12:30AM Fri, Sat, Sun & Mon
	R11	Forum Shops	D	10:00PM - 10:30PM	D	7:30PM - 11:30PM	D	7:30PM - 11:30PM	-	-	-	X	-	7:30PM - 11:30PM Sat & Sun
	R13	Casino Royale	D	2:00PM - 1:00AM	D	1:00PM - 1:30AM	D	12:00PM - 1:30AM	-	-	-	X	-	2:00PM - 1:00AM Fri, Sat & Sun
	R14	Venetian S	-	-	-	-	-	-	-	-	-	-	-	
Pedestrian Bridges	R1	Trop W Bridge*	D	10:00PM - 11:30AM	D	8:30PM - 12:00AM	D	8:30PM - 12:00AM	-	-	-	X	-	
	R4	Harm W Bridge	D	9:30PM - 12:30AM	D	8:30PM - 12:30AM	D	7:00PM - 12:30AM	-	-	X	X	-	8:30PM - 12:30AM Sat & Sun
	R7	Flam W Bridge	D	9:00PM - 9:30PM	D	3:30PM - 11:30PM	D	3:30PM - 12:00AM	-	-	-	X	-	3:30PM - 11:30PM Sat & Sun

*Calculated assuming removal of existing trash enclosure.

Typical Weekend - Existing Walkway

	Location ID	Segment Name	Friday		Saturday		Sunday		Weekday		Feb-Nov-Dec			Shortest Period of Time Common to All Days (Greater than 4 hours)
			LOS	Hours of Friday LOS	LOS	Hours of Sat LOS	LOS	Hours of Sunday LOS	LOS	Hours of Weekday LOS	Jan	Nov	Dec	
Walkways with No Pedestrian Containment	R2	The Plaza	D	9:00PM - 12:00AM	D	8:30PM - 12:30AM	-	-	-	-	-	X	-	
	R3	Harley D	D	8:00PM - 12:30AM	D	8:00PM - 12:30AM	D	9:00PM - 12:00AM	-	-	-	X	-	8:00PM - 12:30AM Fri & Sat
	R6	Bally's S	-	-	-	-	-	-	-	-	-	-	-	
	R8	Caesars	-	-	-	-	-	-	-	-	-	-	-	
	R12	Harrah's	D	9:00PM - 12:00AM	D	9:00PM - 12:30AM	-	-	-	-	-	X	-	
	R16	TI Bus Stop	D/E	7:30PM - 12:30AM	D/E	6:30PM - 12:30AM	D	7:30PM - 11:30PM	D/E/F	7:30PM - 11:30PM	X	X	-	7:30PM - 12:30AM Fri & Sat
	R17	Treasure Island	D/E	8:30PM - 10:30PM	D/E/F	8:30PM - 10:30PM	D/E	8:30PM - 10:30PM	D/E	8:30PM - 10:30PM	X	X	-	
Walkways with Containment	R5	Cosmo	-	-	-	-	-	-	-	-	-	-	-	
	R9	Flamingo	-	-	-	-	-	-	-	-	-	-	-	
	R10	Coliseum	D/E/F	1:30PM - 12:30AM	D/E/F	1:00PM - 12:30AM	D/E/F	2:30PM - 12:30AM	D/E/F	2:30PM - 12:30AM	X	X	X	2:30PM - 12:30AM Everyday
	R11	Forum Shops	-	-	-	-	-	-	-	-	-	-	-	
	R13	Casino Royale	D/E	2:30PM - 1:00AM	D/E	12:30PM - 1:00AM	-	8:30PM - 12:00AM	-	8:30PM - 12:00AM	X	X	-	2:30PM - 1:00AM Fri & Sat
	R14	Venetian S	D	9:00PM - 11:30PM	D	8:30PM - 11:30PM	-	-	-	-	-	X	-	
Pedestrian Bridges	R1	Trop W Bridge	-	-	-	-	-	-	-	-	-	-	-	
	R4	Harm W Bridge	-	-	-	-	-	-	-	-	-	-	-	
	R7	Flam W Bridge	-	-	-	-	-	-	-	-	-	-	-	

Table 3.42 – Walkways which Exceed LOS C - Time of Day, Day of Week, and Month of Year (with an obstruction)

Holiday Weekend - with a Non-Permanent Obstruction Effective Walk Width Reduction

	Location ID	Segment Name	Friday LOS	Hours of Friday LOS	Saturday LOS	Hours of Sat LOS	Sunday LOS	Hours of Sunday LOS	Monday LOS	Hours of Monday LOS	Jan	Feb-Nov	Dec	Shortest Period of Time Common to All Days (Greater than 4 hours)
Walkways with No Pedestrian Containment	R2	The Plaza	D	1:00PM - 10:30PM	D/E	12:00PM - 2:00AM	D/E	12:00PM - 2:00AM	D	2:00PM - 4:30PM	X	X	-	1:00PM - 10:30PM Fri, Sat & Sun
	R3	Harley D	D/E	12:00PM - 2:00AM	D/E	11:00PM - 2:30AM	D/E	11:00PM - 2:30AM	D	1:00PM - 10:30PM	X	X	X	1:00PM - 10:30PM Fri, Sat, Sun & Mon
	R6	Bally's S	D	3:30PM - 11:00PM	D/E	12:00PM - 1:30AM	D/E	12:00PM - 1:30AM	D	4:00PM - 4:30PM	X	X	-	3:30PM - 11:00PM Fri, Sat & Sun
	R8	Caesars	D	9:00PM - 12:00PM	D	3:00PM - 12:00PM	D	3:00PM - 12:30PM	D	9:00PM - 9:30PM	X	X	-	3:00PM - 12:00PM Fri, Sat & Sun
	R12	Harrah's	D/E	11:00AM - 1:30AM	D/E	10:30AM - 2:00AM	D/E	10:30AM - 3:00AM	D	12:00PM - 12:30AM	X	X	X	12:00AM - 12:30AM Fri, Sat, Sun & Mon
	R16	TI Bus Stop	D/E/F	9:30AM - 3:30AM	D/E/F	9:30AM - 3:30AM	D/E/F	9:30AM - 3:30AM	D/E/F	9:30AM - 3:30AM	X	X	X	9:30AM - 3:30AM Fri, Sat, Sun & Mon
	R17	Treasure Island	D/E/F	5:30PM - 2:00AM	D/E/F	5:30PM - 2:00AM	D/E/F	5:30PM - 2:00AM	D/E/F	5:30PM - 2:00AM	X	X	X	5:30PM - 2:00AM Fri, Sat, Sun & Mon
Walkways with Containment	R5	Cosmo	D	6:30PM - 1:00AM	D/E	1:00PM - 2:00AM	D/E	1:00PM - 2:00AM	D	6:30PM - 12:30AM	X	X	-	6:30PM - 12:30AM Fri, Sat, Sun & Mon
	R9	Flamingo	D/E	11:30AM - 2:30AM	D/E	11:30AM - 3:30AM	D/E	11:30AM - 3:30AM	D	12:00PM - 1:30AM	X	X	X	12:00PM - 1:30AM Fri, Sat, Sun & Mon
	R10	Coliseum	D/E/F	8:30AM - 2:30AM	D/E/F	8:30AM - 2:30AM	D/E/F	8:30AM - 2:30AM	D/E/F	8:30AM - 2:30AM	X	X	X	8:30AM - 2:30AM Fri, Sat, Sun & Mon
	R11	Forum Shops	D	10:00PM - 11:30PM	D/E	5:00PM - 12:00AM	D/E	4:30PM - 12:00AM	D	10:00PM - 10:30PM	X	X	-	5:00PM - 12:00AM Fri, Sat & Sun
	R13	Casino Royale	D/E/F	11:00AM - 2:30AM	D/E/F	11:00AM - 3:30AM	D/E/F	11:00AM - 3:30AM	D/E/F	11:30AM - 1:30AM	X	X	X	11:30AM - 1:30AM Fri, Sat, Sun & Mon
	R14	Venetian S	-	-	D	2:30PM - 1:00AM	D	2:30PM - 1:00AM	-	-	-	X	-	2:30PM - 1:00AM Sat & Sun
	R15	Venetian N	D	1:30PM - 1:30AM	D/E	11:00AM - 2:00AM	D/E	11:00AM - 2:00AM	D	2:30PM - 1:00AM	X	X	-	2:30PM - 1:00AM Fri, Sat, Sun & Mon
Pedestrian Bridges	R1	Trop W Bridge*	D	8:30PM - 12:00AM	D/E	12:30PM - 12:00AM	D/E	12:30PM - 12:00AM	D	10:00PM - 11:30PM	X	X	-	12:30PM - 12:00AM Sat & Sun
	R4	Harm W Bridge	D	7:00PM - 1:00AM	D/E	3:30PM - 1:00AM	D/E	1:30PM - 1:00AM	D	9:00PM - 12:30AM	X	X	-	7:00PM - 1:00AM Fri, Sat & Sun
	R7	Flam W Bridge	D	3:30PM - 11:30PM	D/E	1:00PM - 12:30AM	D/E	12:30PM - 12:30AM	-	-	-	X	-	3:30PM - 11:30PM Fri, Sat & Sun

*Calculated assuming removal of existing trash enclosure.

Typical Weekend - with a Non-Permanent Obstruction Effective Walk Width Reduction

	Location ID	Segment Name	Friday LOS	Hours of Friday LOS	Saturday LOS	Hours of Sat LOS	Sunday LOS	Hours of Sunday LOS	Weekday LOS	Hours of Weekday LOS	Jan	Feb-Nov	Dec	Shortest Period of Time Common to All Days (Greater than 4 hours)
Walkways with No Pedestrian Containment	R2	The Plaza	D/E	1:00PM - 1:30AM	D/E	12:00PM - 1:30AM	D	8:00PM - 1:00AM	D	8:00PM - 1:00AM	X	X	-	8:00PM - 1:00AM Everyday
	R3	Harley D	D/E	11:30AM - 2:00AM	D/E	11:30AM - 2:00AM	D/E	11:30AM - 1:00AM	D/E	1:00PM - 1:30AM	X	X	X	1:00PM - 1:30AM Everyday
	R6	Bally's S	-	-	D	10:00PM - 10:30PM	-	-	-	-	-	X	-	-
	R8	Caesars	D	9:00PM - 11:30PM	D	9:00PM - 11:30PM	D	9:00PM - 9:30PM	-	-	-	X	-	-
	R12	Harrah's	D/E	1:00PM - 12:30AM	D/E	1:00PM - 1:00AM	D	7:00PM - 12:30AM	D	8:00PM - 12:30AM	X	X	-	8:00PM - 12:30AM Everyday
	R16	TI Bus Stop	D/E/F	10:30AM - 3:00AM	D/E/F	10:30AM - 3:00AM	D/E/F	10:30AM - 3:00AM	D/E/F	10:30AM - 3:00AM	X	X	X	10:30AM - 3:00AM Everyday
	R17	Treasure Island	D/E/F	5:30PM - 2:00AM	D/E/F	5:30PM - 2:00AM	D/E/F	5:30PM - 2:00AM	D/E/F	5:30PM - 2:00AM	X	X	X	5:30PM - 2:00AM Everyday
Walkways with Containment	R5	Cosmo	-	-	D	10:00PM - 11:00PM	-	-	-	-	-	X	-	-
	R9	Flamingo	D	1:30PM - 1:00AM	D	12:00PM - 1:30AM	D	2:00PM - 12:30AM	D	6:00PM - 10:30PM	-	X	-	2:00PM - 12:30AM Fri, Sat & Sun
	R10	Coliseum	D/E/F	10:00AM - 2:30AM	D/E/F	10:00AM - 2:30AM	D/E/F	10:30AM - 2:30AM	D/E/F	10:30AM - 2:30AM	X	X	X	10:30AM - 2:30AM Everyday
	R11	Forum Shops	-	-	D	9:00PM - 10:30PM	-	-	-	-	-	X	-	-
	R13	Casino Royale	D/E/F	11:00AM - 2:30AM	D/E/F	10:00AM - 2:30AM	D/E/F	11:30AM - 1:00AM	D/E/F	11:30AM - 1:00AM	X	X	X	11:30AM - 1:00AM Everyday
	R15	Venetian N	D/E	2:30PM - 1:00AM	D/E	2:30PM - 1:00AM	D/E	4:30PM - 12:30AM	D/E	8:30PM - 12:00AM	X	X	X	4:30PM - 12:30AM Fri, Sat & Sun
Pedestrian Bridges	R1	Trop W Bridge	-	-	-	-	-	-	-	-	-	-	-	-
	R4	Harm W Bridge	-	-	D	9:30PM - 12:30AM	-	-	-	-	-	X	-	-
	R7	Flam W Bridge	-	-	D	9:00PM - 9:30PM	-	-	-	-	-	X	-	-

4 CONCLUSIONS AND RECOMMENDATIONS

The conclusions and recommendations discussed in this section are based on the observation of 4,835,000 pedestrians, 160 hours of in-field agent observation and data collection, and the detailed data analysis and evaluation. General conclusions and recommendations are provided in relation to pedestrian safety and infrastructure improvement throughout the study corridor of Las Vegas Boulevard. Specific mitigation for constrained walkways are detailed on Figure 4.2 and described in detail below. Recommendations are also provided for consideration in updating the current no-obstructive use ordinance (see Section 4.3).

4.1 General Conclusions and Recommendations

The following general conclusions are provided recognizing the importance of maintaining the economic vitality of Las Vegas Boulevard (the “Strip”) through the improvement and maintenance of a safe pedestrian walkway system.

- The results of this study continue to support the no-obstruction zone recommendations of the 1994 Lee Engineering Pedestrian Study as incorporated into Clark County Code Chapter 16.11 where obstructive uses are not permitted near a signalized intersection, access drive or mid-block cross walk.
- Clark County entitlement requirements on new construction within the Resort Corridor should continue to require pedestrian walks to be designed for a minimum effective walkway width (W_E) of ten feet (10') or a pedestrian walkway Level of Service (LOS) of C or better. Based on the pedestrian volumes observed in this study, some future sidewalks within the central or inner portions of the study corridor will require walkway widths of over 15 feet (W). A walkway with 15 feet of effective width (W_E) can serve up to 2,250 pedestrians in 15 minutes while maintaining a LOS of C.
- The study observed a significant number of individuals creating undue obstruction in the current no-obstructive use zones at intersections and driveways. This study provides additional support and justification to maintain these areas free from obstructions during peak walkway usage. Maintaining no-obstructive use zones at intersections, midblock crosswalks and access drive entrances reduces congestion which allows for increased visibility and enhanced walkway safety.
- The pedestrian bridges have constrained widths and are an integral part of the pedestrian walkway system. Based upon the observed pedestrian volumes, and walkway LOS, it is appropriate to designate the pedestrian bridges as no-obstruction zones. Pedestrian bridges should be maintained free of any obstructions, including obstructions like trash enclosures. In addition the areas on and around stair landings, elevator waiting areas, along with escalator approach and departure landing zones should also be maintained free of any obstructions.

- New development and reconstruction projects should incorporate the removal, replacement and/or installation of no-obstructive use zone signs and white painted sidewalk markings as appropriate, into the projects' civil improvement drawings.
- When a driveway has been abandoned or is no longer in active use, the designation of no-obstructive use zone should be removed from that area.
- The conducted walking speed studies were useful in understanding tourist leisure walking speeds and the walking dynamics of Las Vegas Boulevard (the “Strip”). However, the walking speed level of service (LOS) procedures of the 2010 Highway Capacity Manual (HCM) were not found to be as effective in determining walkway congestion levels as the pedestrian volume LOS evaluation procedures. It is recommended that future studies of the pedestrian LOS along Las Vegas Boulevard continue to use only the pedestrian volume LOS evaluation procedures of the HCM.
- LOS evaluations at bus stops suggest that where insufficient queue area is identified, bus stops should be reserved for bus patrons by restricting non-permanent obstructions. The LOS evaluations concluded that all Type 2 and Type 3 bus stops should allow the area between the queue area and the curb to be available for only queued and walking pedestrians with a delineated no-obstructive use zone. In addition, from field observations, all Type 1 bus stops should also be considered for no-obstructive use zones to encourage transit use by maintaining queue areas of LOS C or better and aiding pedestrian flow in front of Type 1 bus stops.

4.1.1 Safety Enhancements

During the study collection periods, general observations of the pedestrian activities and walkway conditions within the study corridor were conducted. The following recommendations are given as general safety enhancements based on observations made during data collection and study evaluations:

- It is recommended that pedestrian containment be considered in the median of Las Vegas Boulevard throughout the study corridor where no adjacent sidewalk containment exists to encourage the use of pedestrian bridges and signalized crosswalks.
- Pedestrian crosswalks along Las Vegas Boulevard should be a minimum of 25-feet in width to accommodate the observed pedestrian volumes at signalized crossings and improve visibility of the crossing.
- To improve pedestrian safety, a feasibility study should be conducted to evaluate the possible benefits of the installation of median refuge islands for at-grade crosswalks along Las Vegas Boulevard within the study area.
- Pedestrian bridge escalators and elevators should be maintained with a schedule that provides a high reliability of service. It is

important to have these facilities be fully operational during holiday weekends. The capacity of the pedestrian bridges is severely impacted when the escalators are not functioning. Picture 4.1 shows two escalators not functioning and a queue forming to use the stairs on the holiday Saturday of May 26, 2012.

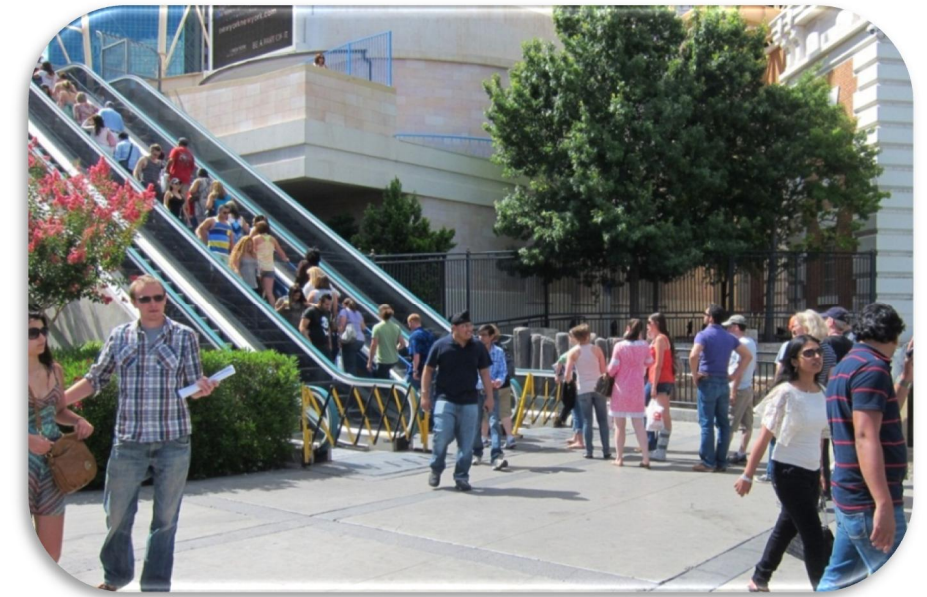

Picture 4.1 – Stairway Queue due to Non-Functional Escalators.

- At the present time, the RTC maintains a text service providing information on bus stop arrival times. For the “Strip”, it is recommended that the RTC consider implementing an additional system to display real-time arrival time for transit vehicles at each of the bus stops within the study corridor. Not only will this enhance the transit system, but it will help mitigate the need to step out into the street to see if the bus is coming (see Picture 4.2). This is especially useful in the study corridor due to the number of visitors and tourists who are unfamiliar with the local transit system and texting service. A tourist being aware of the bus arrival time may elect to not wait for the next bus and continue to walk.
- Pedestrian bridge lighting should be studied, reviewed, and lighting levels adjusted as appropriate to provide improved night time security and safety.
- Daytime lighting levels of the pedestrian bridge stairwell at the north end of the Harmon Avenue east pedestrian bridge should be reviewed and increased as appropriate for various times of day, especially during twilight hours (see Picture 4.3).

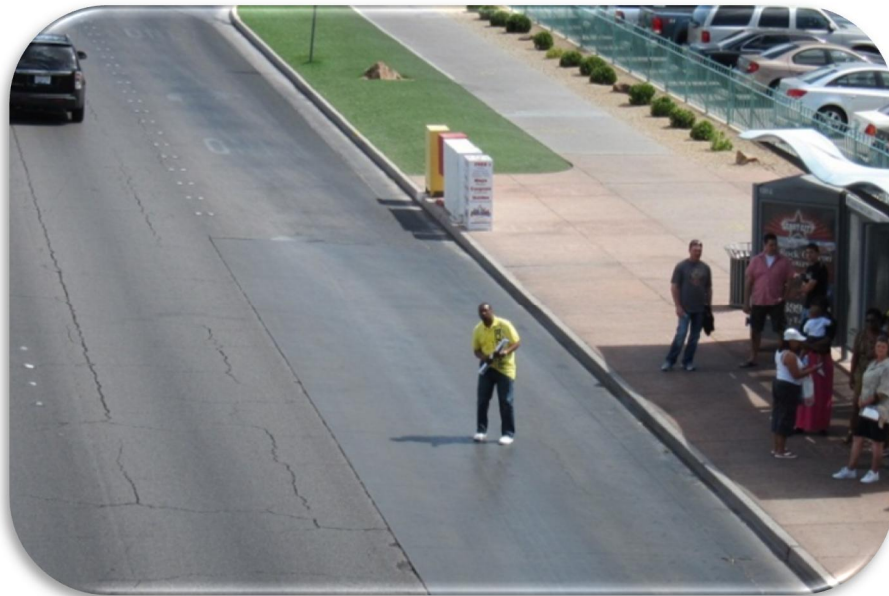

Picture 4.2 – Bus Patron in Street Looking for Arriving Bus.



Figure 4.1 – Saw-tooth Walkway that Encourages Walking in Street

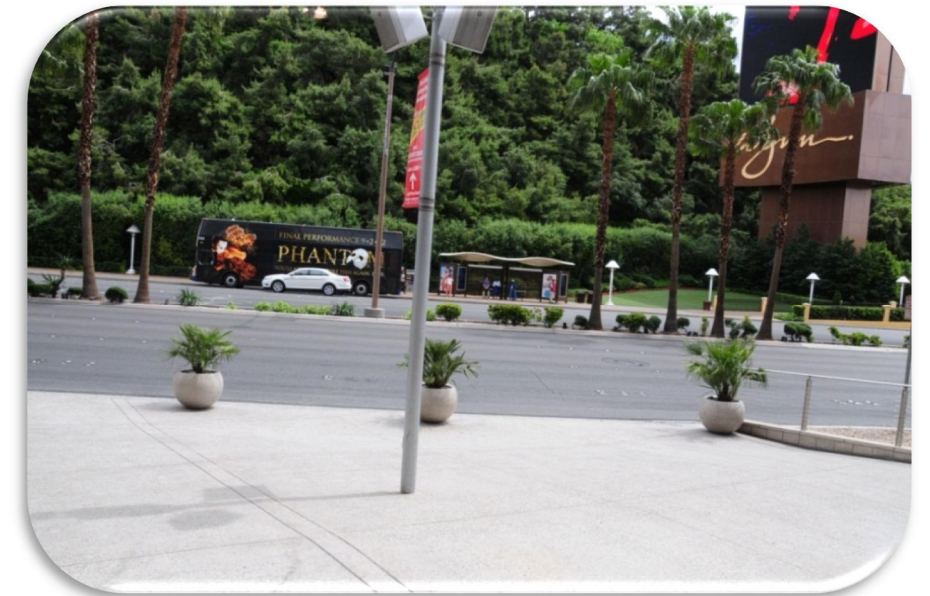

Picture 4.5 – Fashion Show Mall Boulevard Access – No Pedestrian Containment.

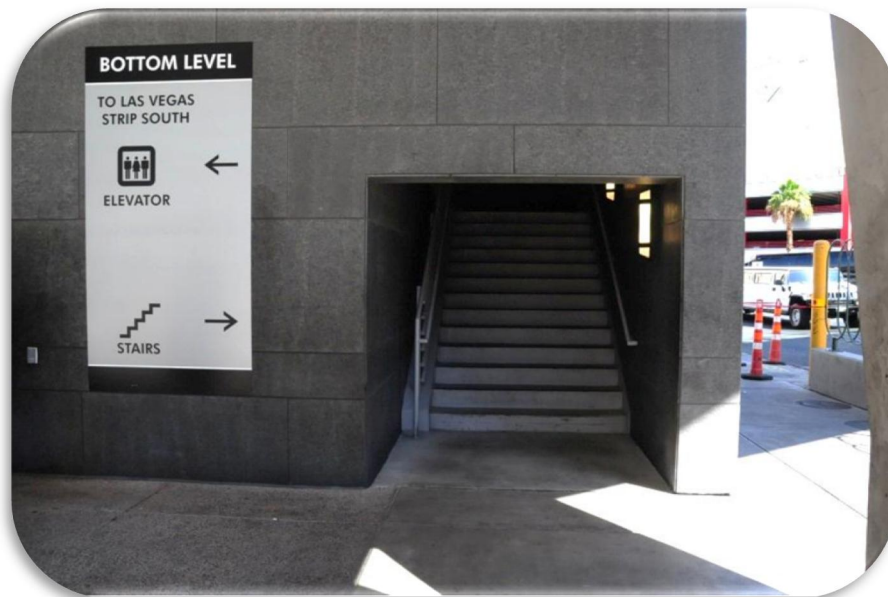

Picture 4.3 – Stairwell at Harmon East Pedestrian Bridge.

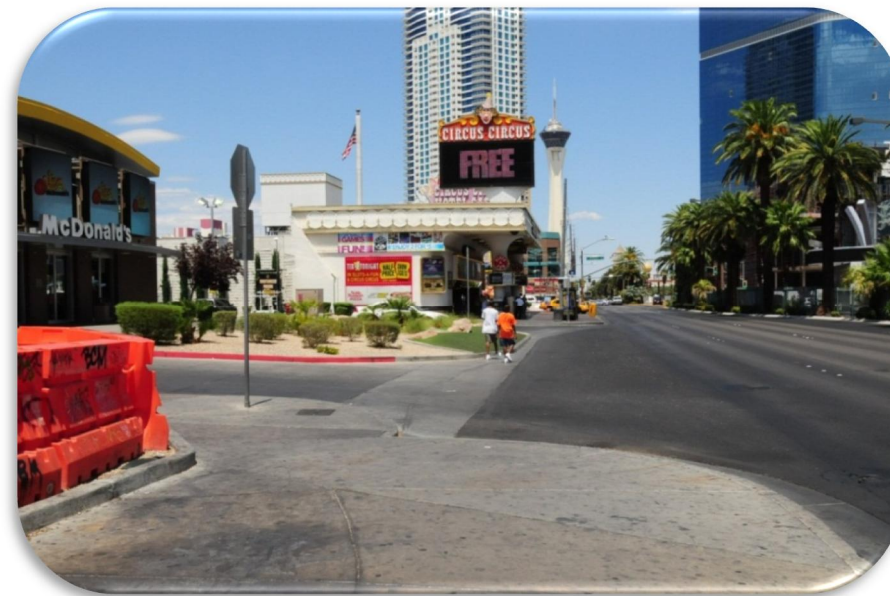

Picture 4.4 – Pedestrians in Street at McDonalds.



Picture 4.6 – Pedestrians in Street in front of Fashion Show Mall.

- At the McDonald's south of Circus Circus Drive, a study should be conducted to recommend either temporary sidewalk improvements directly along Las Vegas Boulevard, pedestrian containment and/or additional way finding signs to encourage pedestrians to use the existing walkway as constructed (see Figure 4.1 and Picture 4.4).

- A study of pedestrian containment in front of the Fashion Show Mall should be conducted. The open walkway for emergency mall evacuation provides direct pedestrian access to Las Vegas Boulevard. This allows pedestrians to enter the vehicle travel lanes and walk in the street between the pedestrian containment measures of the Spring Mountain Road pedestrian bridges (see Picture 4.5 and Picture 4.6).

4.2 Infrastructure Improvement Recommendations

Specific areas of concern identified by field observations and data evaluation are presented along with recommended mitigation strategies. The mitigation measures are classified as short, intermediate and long term. Short term measures are relatively low cost measures with estimated implementation times of less than one year. Intermediate measures may be more costly and require multi-agency and property coordination to implement. Intermediate measures can require 1 to 3 years to implement. Long term measures require additional study and significant planning and design for implementation which would require more than 3 years to implement. The locations of the following areas of concern are shown in Figure 4.2 in relationship to the study corridor.

Location A

This location is on the east side of Las Vegas Boulevard generally across from Mandalay Bay Hotel/Casino. Although pedestrian volumes in this area are minimal and no non-permanent obstructions were observed in this area, the sidewalk width is reduced due to a series of fire hydrants and associated bollards as illustrated in Picture 4.7. At this particular location there is only 32 inches of width between the hydrant and the curb.



Picture 4.7 – Location A at 8 Motel Mart.

Recommendation (Short Term):

- Remove bollards, as appropriate, and relocate fire hydrants within this area of Las Vegas Boulevard out of the sidewalk to provide a minimum of 5 feet of clear walkway.

Location B

On the northeast corner of the intersection of MGM Drive/Rue de Monte Carlo is an area of restricted sidewalk width. The large pedestrian volumes which travel both north/south and east/west at this signalized intersection queue at this constrained flow location. The sidewalk is restricted due to a signal controller cabinet and service pedestal. Due to elevation differences, there is also a railing in front of the Hard Rock Cafe (on the north corner) which further channelizes pedestrians into a narrower walkway area (see Picture 4.8).



Picture 4.8 – Location B near Hard Rock Cafe at MGM Drive.

Recommendation (Short Term):

- Crosswalk delineation should be restriped to provide a 25 feet wide crosswalk to match the approaching walkways on the north and south of MGM Drive.

Recommendation (Intermediate Term):

- The County should work with the property owner and Nevada Power Company to relocate the traffic controller and power service out of the walkway.
- Railing in front of Hard Rock Café and walkway grades should be studied and modified, as appropriate, to provide a wider pedestrian walkway.

Recommendation (Long Term):

- Study the feasibility of a pedestrian bridge at this location to address at-grade crossings of Las Vegas Boulevard.

Location C

At the Harley Davidson Cafe on the southeast corner of Las Vegas Boulevard and Harmon Avenue, an existing concrete wall serves as pedestrian containment and fenced landscaping create a restricted walkway width of eight feet (see Picture 4.9).



Picture 4.9 – Location C at Harley Davidson Cafe near Harmon Avenue.

Recommendations (Short Term):

- Enforce no-obstructive use ordinance.
- Per current code, delineate a no-obstructive use zone from the intersection 50 feet south from point of curvature of the curb.
- News racks immediately south of this walkway restriction should be relocated to increase existing pedestrian walkway width (W).

Recommendation (Intermediate Term):

- A pedestrian easement should be obtained from the Harley Davidson property to widen the pedestrian walkway to a minimum effective walk width (W_e) of 10 feet minimum.

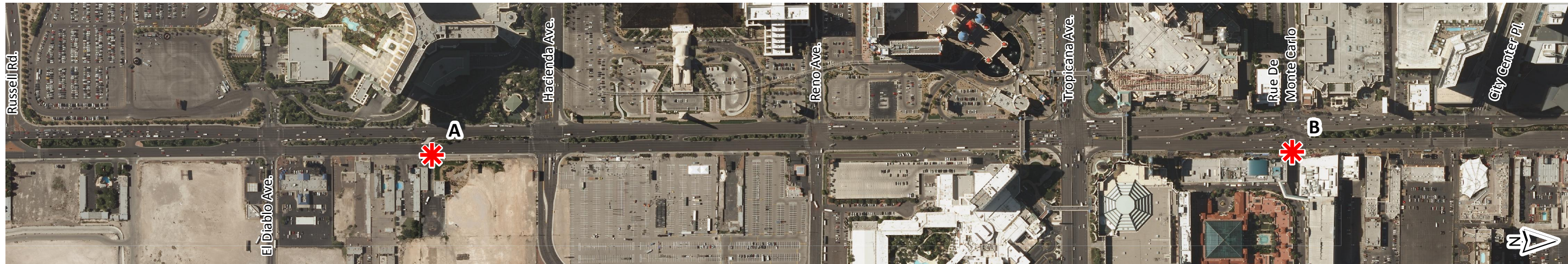

SEE BELOW LEFT

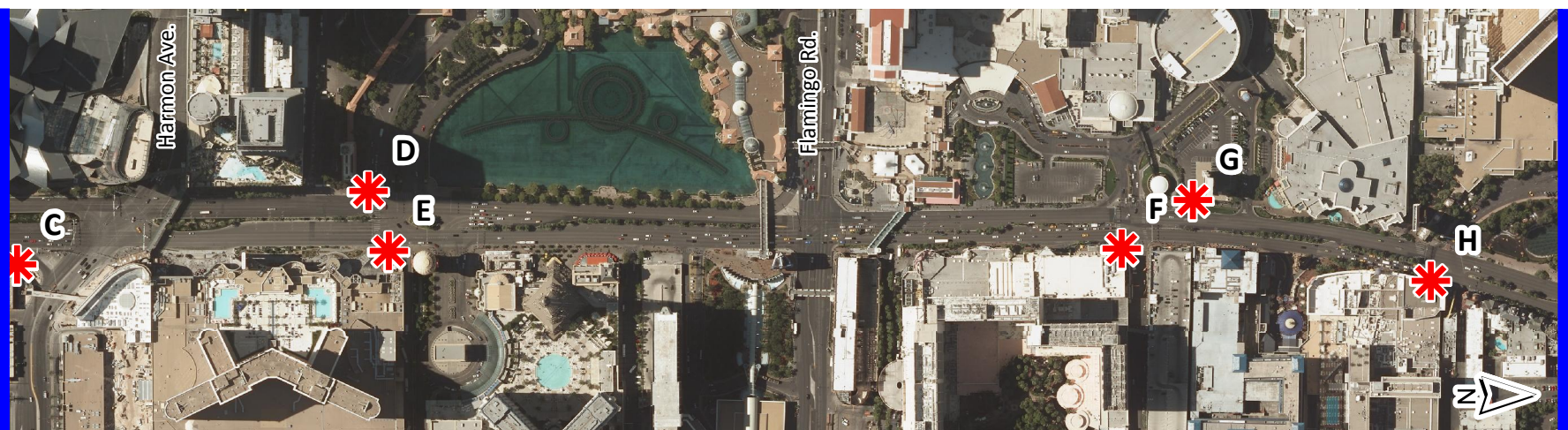

SEE ABOVE RIGHT

SEE RIGHT
SEE LEFT

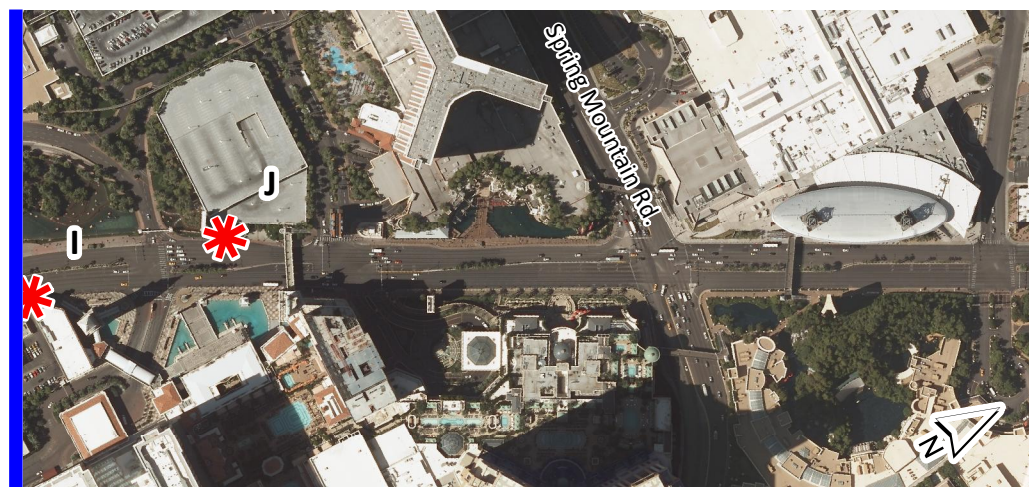

SEE BELOW LEFT

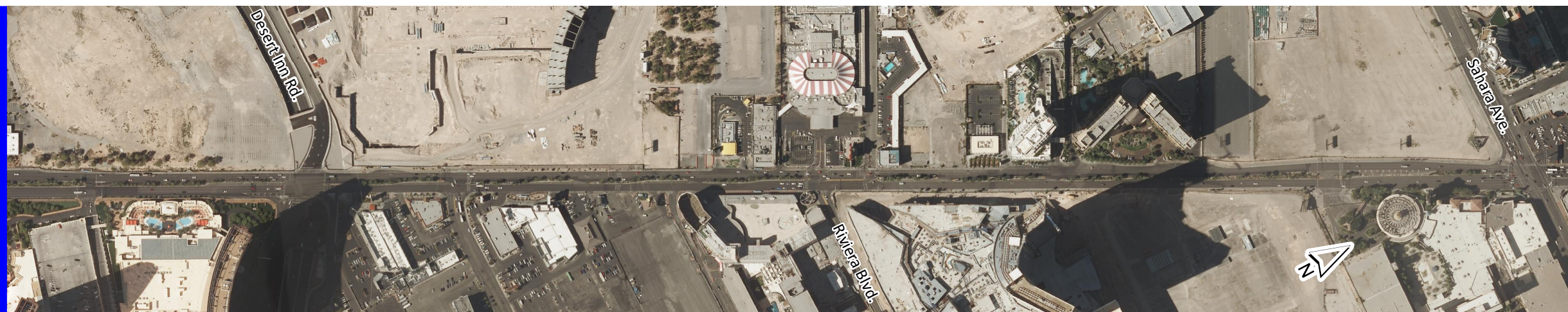

SEE ABOVE RIGHT

Legend

 Location

LOCATIONS OF PEDESTRIAN INFRASTRUCTURE IMPROVEMENTS

FIGURE 4.2 140

Location D

On the west side of Las Vegas Boulevard and south of the Bellagio fountain is a pedestrian refuge island (see Picture 4.10). This island harbors pedestrians between “WALK” indications when crossing Bellagio Drive and Las Vegas Boulevard. The queue area on the pedestrian island was observed to be at capacity multiple times during the data collection efforts.



Picture 4.10 – Location D – “Pork chop” Refuge Island near Bellagio Hotel/Casino.

Recommendation (Short Term):

- Enforce the no-obstructive use ordinance in this area

Recommendations (Long Term):

- Study the safety and feasibility of providing a Las Vegas Boulevard median refuge for pedestrians crossing Las Vegas Boulevard in coordination with Location E.
- Study the feasibility of a pedestrian bridge at this location to eliminate the at-grade pedestrian crossing (in coordination with Location E).

Location E

Picture 4.11 is at the north end of the Planet Hollywood property. This location experiences congestion and slow walking speeds due to pedestrians queuing to cross Las Vegas Boulevard to the Bellagio Hotel/Casino and those descending the Planet Hollywood Hotel/Casino walkway stairs and escalators. During the study, some of the highest pedestrian volumes were observed near this location.



Picture 4.11 – Location E at North end of Planet Hollywood Hotel/Casino.

Recommendations (Short Term):

- Enforce the no-obstructive use ordinance in this street crossing area. Non-permanent obstructions were prevalent in this area averaging as many as 10.
- Crosswalk widths both northbound and westbound should be widened to 25 feet to meet the pedestrian volume demands.

Recommendations (Long Term):

- Study the safety and feasibility of providing a Las Vegas Boulevard median refuge for pedestrians crossing Las Vegas Boulevard in coordination with Location D.
- Study the feasibility of a pedestrian bridge at this location to eliminate the at-grade pedestrian crossing (in coordination with Location D).

Location F

Location F is constrained by a pedestrian containment fence along Las Vegas Boulevard and the building face of Margaritaville. A fire hydrant also reduces the amount of effective walkway width and was observed to be a tripping hazard when the area is congested due to its lack of height as shown in Picture 4.12. The adjacent Las Vegas Boulevard crosswalk to Caesars Palace Hotel/Casino and the crossing of Caesars Palace Boulevard require pedestrian queuing which result in pedestrian congestion.



Picture 4.12 – Location F in front of Margaritaville.

Recommendation (Short Term):

- Enforce the no-obstructive use ordinance in this area. Non-permanent obstructions were prevalent in this area averaging as many as 10.

Recommendation (Intermediate Term):

- Relocate fire hydrant out of pedestrian walkway to maximum walkway width.

Note – although this concern was present at the time of this study, the construction of the Caesars Linq project may rectify the queuing issue.

Location G

As pedestrian volumes increase, older walkways are requiring additional width. Some of the largest pedestrian volumes were observed near this area of Caesars Palace Hotel/Casino. Location G is physically constrained by landscaping on both sides of the walk (see Picture 4.13). The walkway provides an effective walkway width of five feet.



Picture 4.13 – Location G near Caesars Palace Hotel/Casino.

Recommendation (Short Term):

- Apply the no-obstructive use ordinance to this area to restrict non-permanent obstructions.

Recommendation (Intermediate Term):

- County should coordinate with Caesars Palace Hotel/Casino to widen the existing walkway to provide a minimum effective walkway width of 15 feet.

Location H

Location H is in front of Harrah's Hotel/Casino and serves an east/west crossing of Las Vegas Boulevard for pedestrians crossing to the Mirage Hotel/Casino. The area is constrained by the Harrah's Hotel/Casino building face, signal poles, the street, and landscaping as shown in Picture 4.14.



Picture 4.14 – Location H in front of Harrah's Hotel/Casino.

Recommendation (Short Term):

- Enforce the no-obstructive use ordinance in this area. Non-permanent obstructions were prevalent in this area averaging as many as 15.

Recommendations (Intermediate Term):

- Coordinate with Harrah's to adjust or remove existing landscaping and other obstructions to maximize effective walkway width.
- Install pedestrian containment to encourage use of the existing crosswalk and enhance safety.

Location I

At the south end of the Venetian Hotel/Casino, permanent obstructions cause the effective walkway width (W_E) to be reduced to 6.3 feet. Significant pedestrian volumes were observed in this location. Also, immediately south of this location is the driveway into the Casino Royale Hotel/Casino property which causes queuing of pedestrians when vehicles enter or exit the driveway (see Picture 4.15).

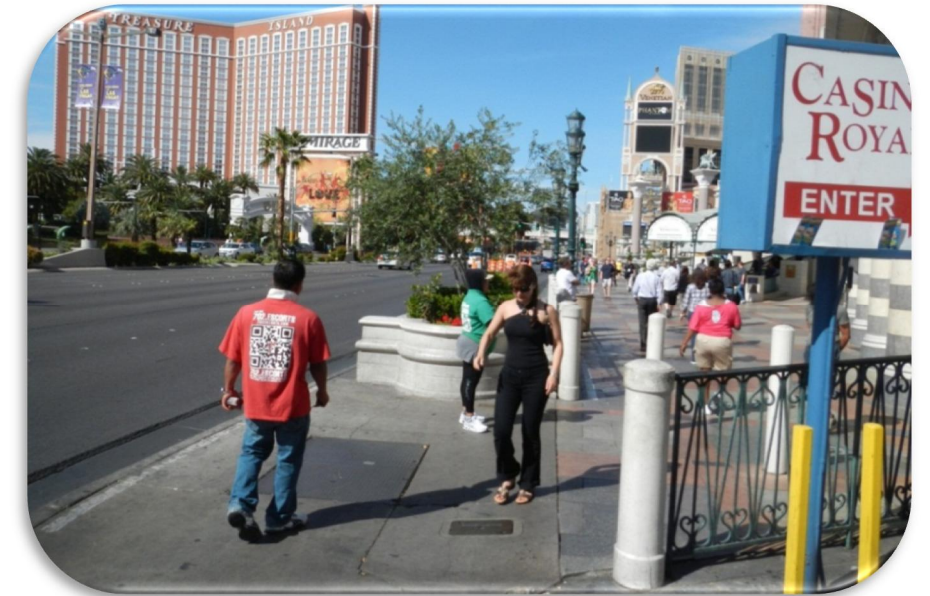

Picture 4.15 – Location I at Casino Royale Driveway.

Recommendation (Short Term):

- Enforce the no-obstructive use ordinance in this area. Non-permanent obstructions were prevalent in this area averaging as many as 8.

Recommendations (Intermediate Term):

- Coordinate with the Venetian Hotel/Casino and the Casino Royale Hotel/Casino on the feasibility to adjust, relocate, or remove existing fencing and bollards to maximize pedestrian walkway width recognizing the adjacent access driveway.
- Extension of pedestrian containment south along the curb to the driveway could further enhance safety for pedestrians.
- Study area for options to maximize sidewalk width which may include adjusting existing landscaping.

Location J

Field observations found the highest number of pedestrians in the street at Location J (see Picture 4.16). The walkway north from the Mirage Hotel/Casino to the Treasure Island bus stop serves a large pedestrian volume especially before and after the Mirage Volcano show and the Sirens at Treasure Island show. The walkway has a width of six feet, which equates to a three foot effective walkway width (W_E).



Picture 4.16 – Location J at Treasure Island Bus Stop

Recommendations (Short Term):

- Enforce the no-obstructive use ordinance in this area. Non-permanent obstructions were prevalent in this area averaging as many as 8.
- Include bus stop area as a no-obstructive use zone

Recommendations (Long Term):

- Widen walkway to provide a minimum effective walkway width (W_E) of 15 feet.
- Consider constructing a bypass walkway behind the existing bus shelter to allow for increased queue area for bus patrons.

4.3 Recommended Updates to No-Obstructive Use Zones

The following recommendations are provided based on the findings of this study and are presented for consideration by the Clark County Board of Commissioners for amendments to the existing no-obstructive use ordinance (Clark County Code of Ordinances Title 16 – Roads and Highways Chapter 16.11 – Obstructive Uses of Public Sidewalks):

- Update ordinance to reflect the current 2010 HCM. The pedestrian methodology in Chapter 13 of the 1985 Highway Capacity Manual is now located in Chapter 23 of the 2010 Highway Capacity Manual.
- No-obstruction zones should be applied to all construction zones affecting pedestrian walkways.
- The no-obstruction zones should be clarified so that dimensions for midblock crosswalks, intersections and driveways are to be measured from and follow the adjacent pedestrian walkway and not the curb. The following exceptions should be addressed:
 - When the measured prohibition distance is greater than the distance to a nearby pedestrian containment fence, wall, or raised landscaping preventing a pedestrian from entering the street;
 - The designation area should follow the front of sidewalk if it veers away from or is separated by landscaping from the curb line;
 - Allow for engineering judgment to be used for unique and unusual walkway conditions.
- No-obstruction zones are recommended at bus stops:
 - For a bus turnout, the no-obstructive use zone should be for the entire bus turnout from the beginning to the end of the curb line deflections for the bus turnout.
 - For curbside bus stops with bus shelters, the no-obstructive use zone should begin and end a minimum of 15 feet from each side of the shelter as installed.
 - At curbside bus stops without a shelter, the no-obstructive use zone should begin 35 feet in the approaching direction and end 15 feet past the bus stop sign post.
- No-obstruction zones are recommended in front of elevators and at the landing areas of escalators and stairs. A study should be conducted to determine the appropriate clear areas that should be provided.

4.3.1 Recommended Time, Place, and Manner No – Obstructive Use Zones

Based on observed pedestrian volumes, level of service, walkway conditions and pedestrian safety concerns, the locations shown in Figure 3.73 within the study corridor, have been identified as walkway segments in which non-

permanent obstruction restrictions should be considered during specific days of the week and times of the day.

To identify the time of day, day of week, and month of year that certain walkway segments within the study corridor should be considered for restriction of non-permanent obstructions, the following steps were taken:

- Effective walkway widths along the entire length of the study corridor were grouped into segments with similar effective walkway widths (see Figure 2.1).
- Pedestrian volumes from all of the count locations were evaluated to identify a common daily peak pedestrian volume time period. This daily time period was found to occur between 9:00 PM and 11:00 PM.
- Pedestrian volumes for the common peak period were assigned to each segment of the study corridor to calculate a peak period LOS using 2010 HCM procedures (see Figure 3.74).
- The LOS analysis resulted in 17 walkway segments that were found to exceed LOS C on the Holiday and/or Typical Saturday (May 26 and/or June 16, 2012) labeled R1 to R17 from south to north (see Figure 3.73 for segment location) (see Figure 3.75 through Figure 3.91 for volume data at each location that exceeded LOS C for more than four hours).
- Figure 3.75 through Figure 3.87 show the volume distribution data at each location for the lowest pedestrian volume day of week where LOS C was exceeded for four hours on the holiday weekend. Similarly, Figure 3.88 through Figure 3.91 display volume distribution data for walkway segments during the typical weekend that exceeded LOS C for more than four hours.
- Walkway segments that resulted in a LOS C were considered further and analyzed to determine if the addition of an obstruction would result in the LOS deteriorating to D or greater. A reduction of the effective walkway width (W_E) of 2.25 feet associated with the obstruction of one person standing on the side of the walkway was applied for the analysis.
- The walkway segments were separated into three categories:
 - Walkways with no pedestrian containment
 - Walkways with pedestrian containment
 - Pedestrian bridges
- The Saturday count data was adjusted using the week-long data and the year-long data, provided by Caesars International, to determine day of week and month of year adjustment factors. The adjustment factors were used to determine time periods when walkway segments were estimated to exceed LOS C for days other than those counted on Saturday May 26 and June 16, 2012.

Table 3.41 summarizes the results of the analysis for possible time of day, day of week and month of year restrictions based solely on pedestrian volumes and walkway widths. Table 3.42 provides a summary of the analysis for possible non-permanent obstruction restrictions including an effective walkway width (W_E) reduction of 2.25 feet for an obstruction (note that the length of time for many areas increase and additional days of week are included).

EXHIBIT A

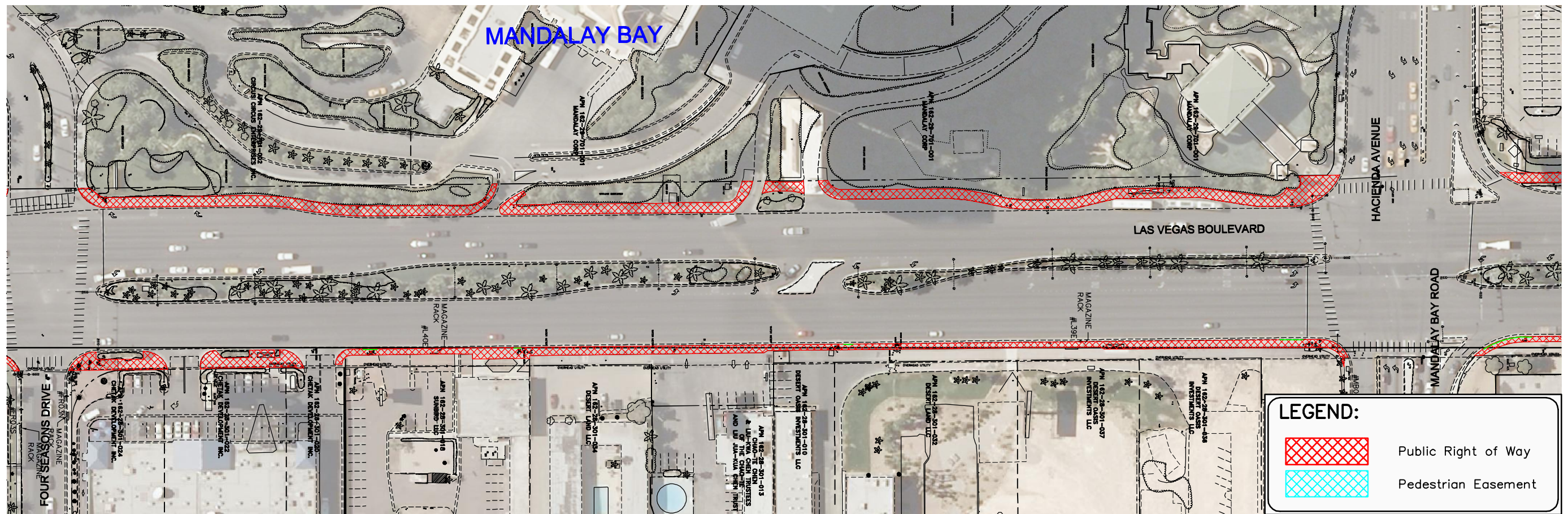
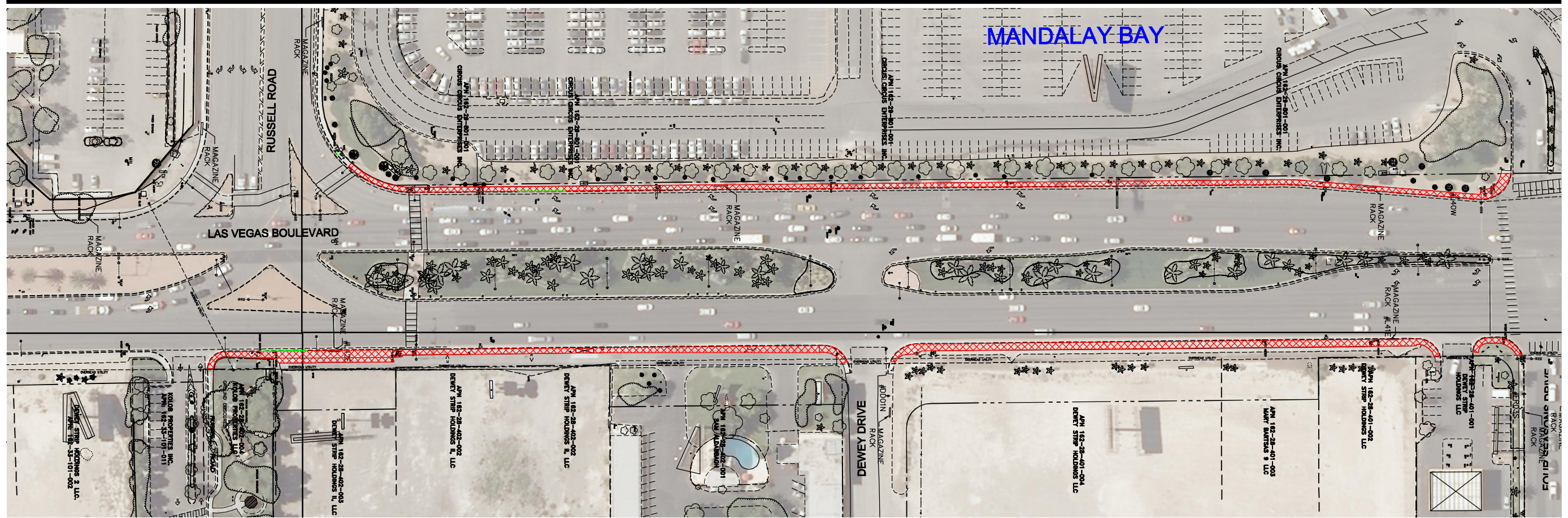

LEGEND:

	Public Right of Way
	Pedestrian Easement

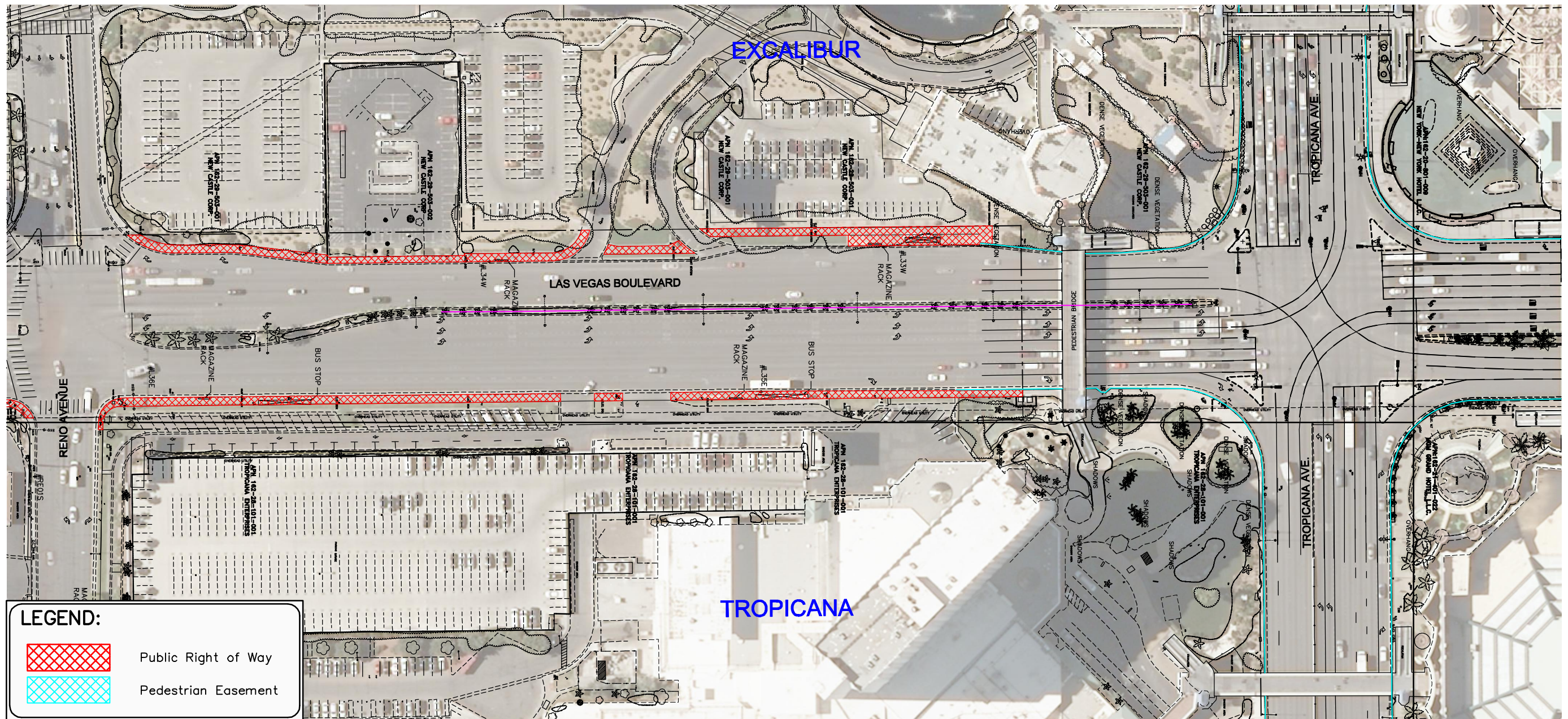
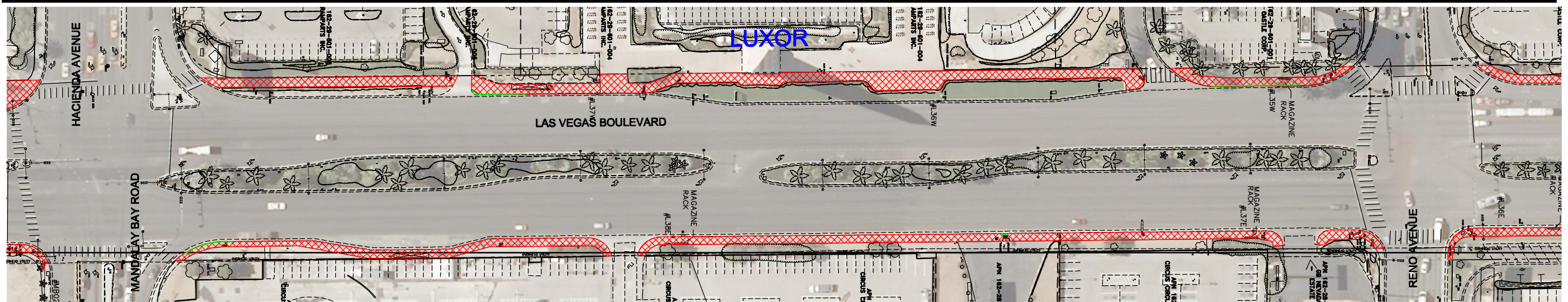

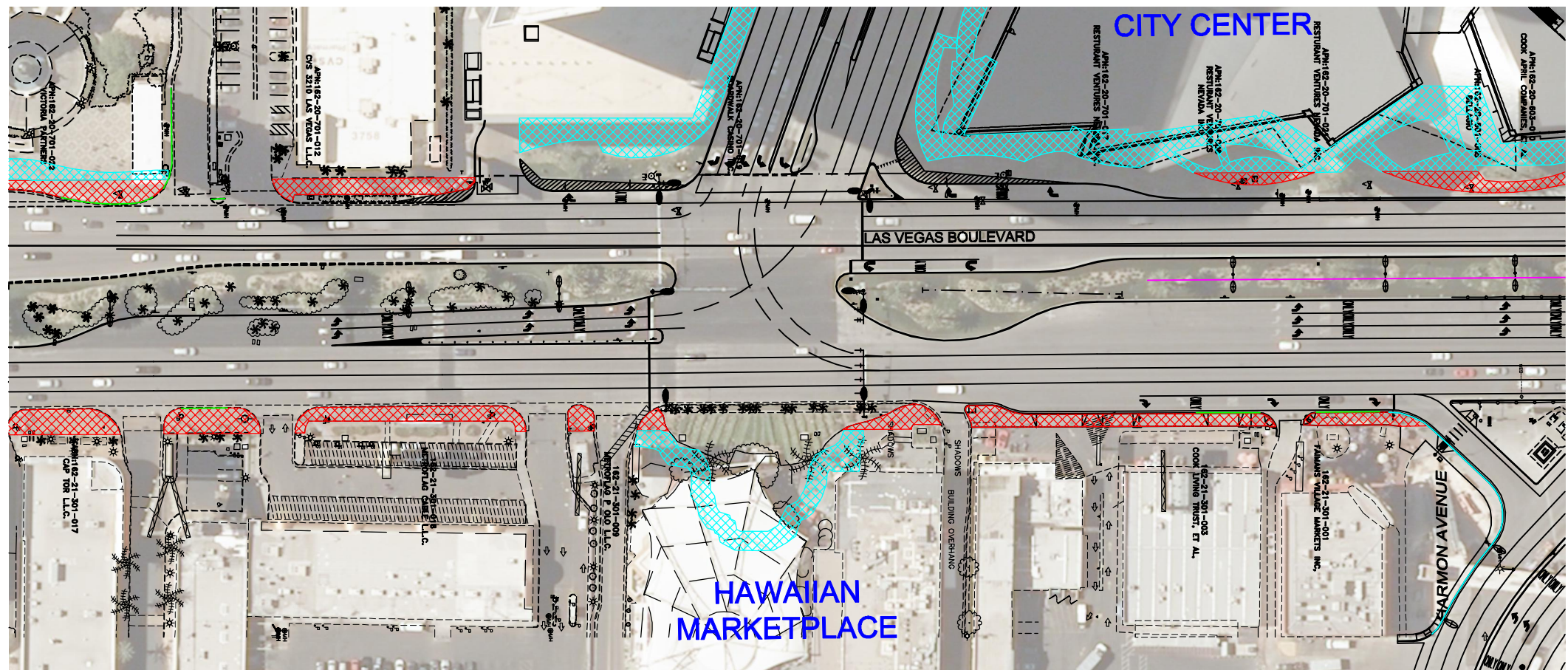
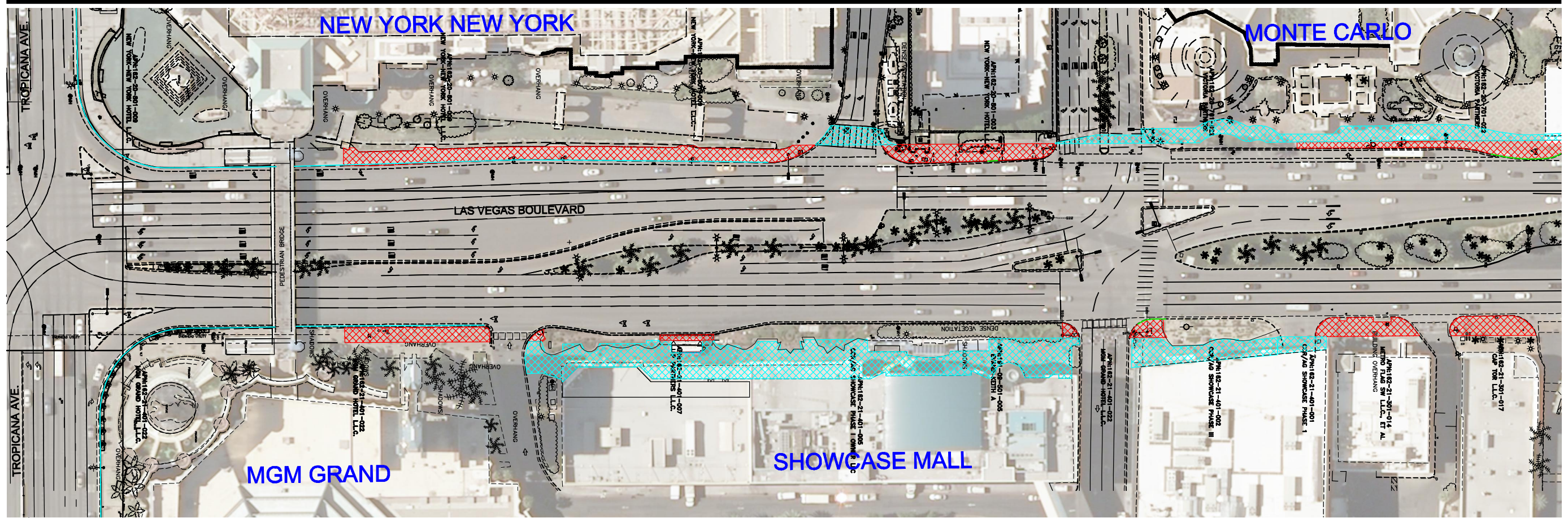

LEGEND:

-  Public Right of Way
-  Pedestrian Easement



LEGEND:

	Public Right of Way
	Pedestrian Easement

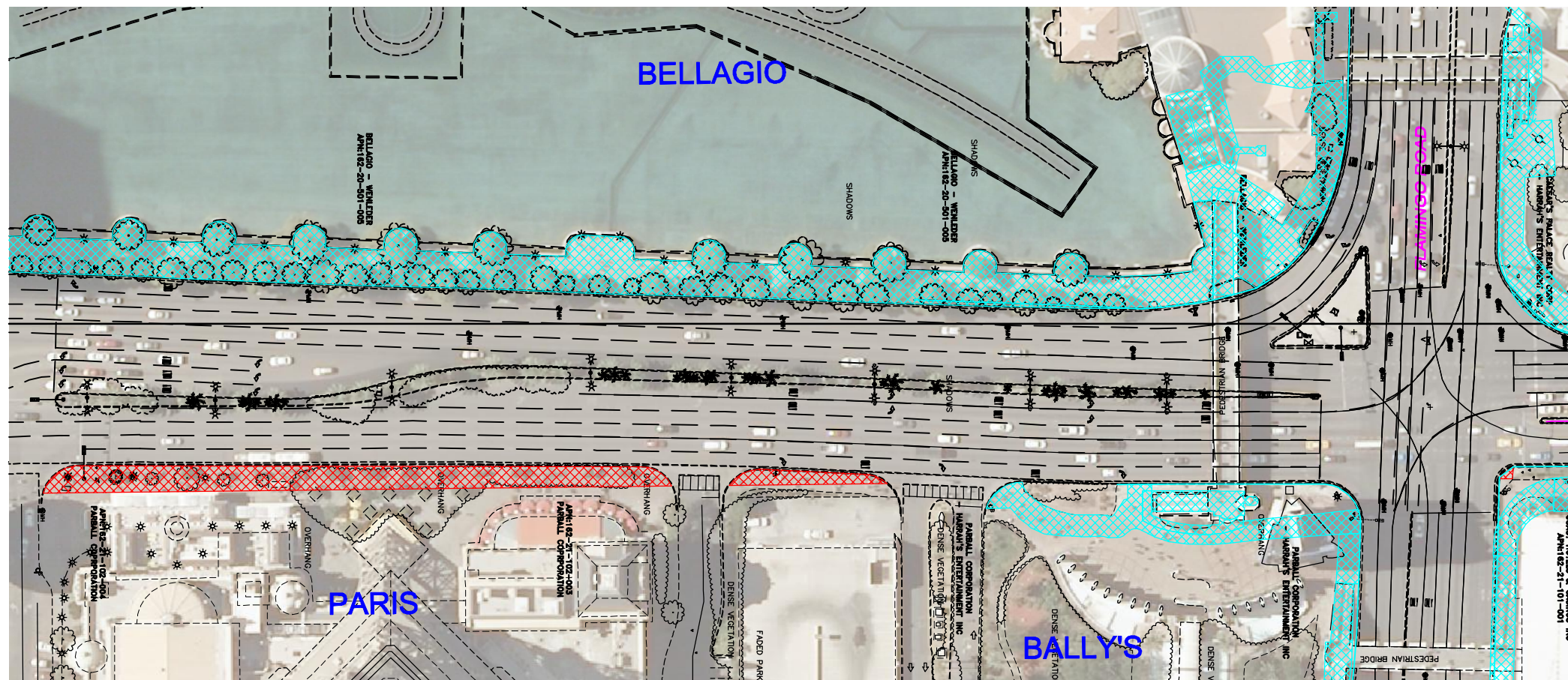
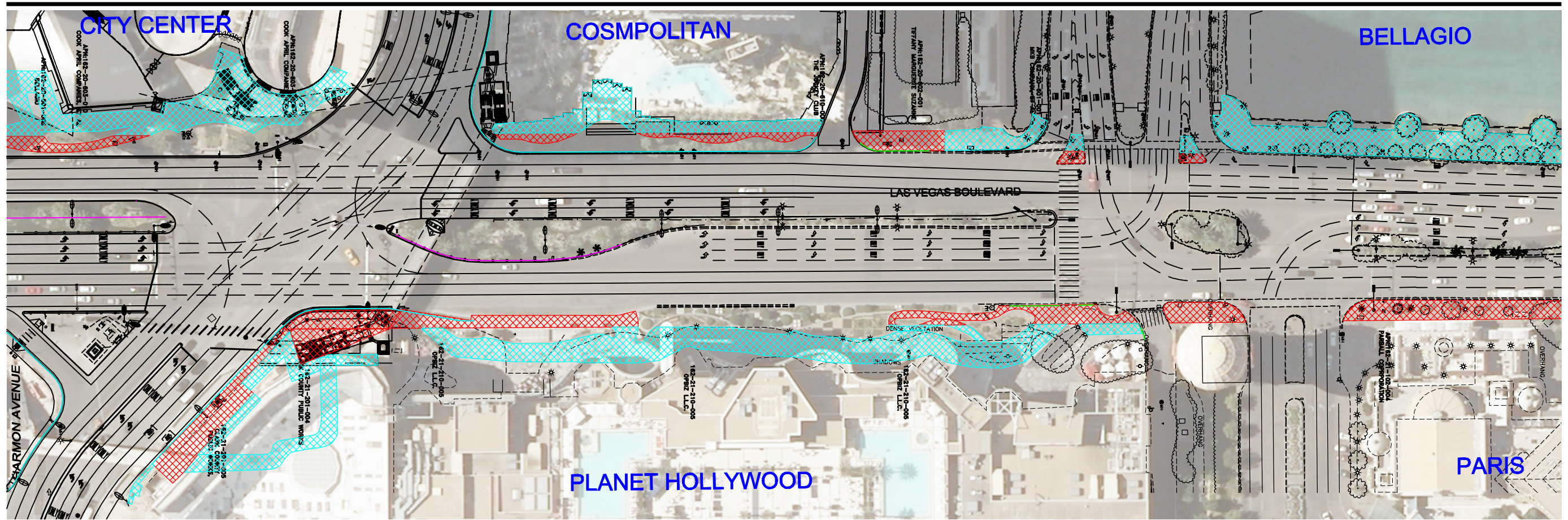

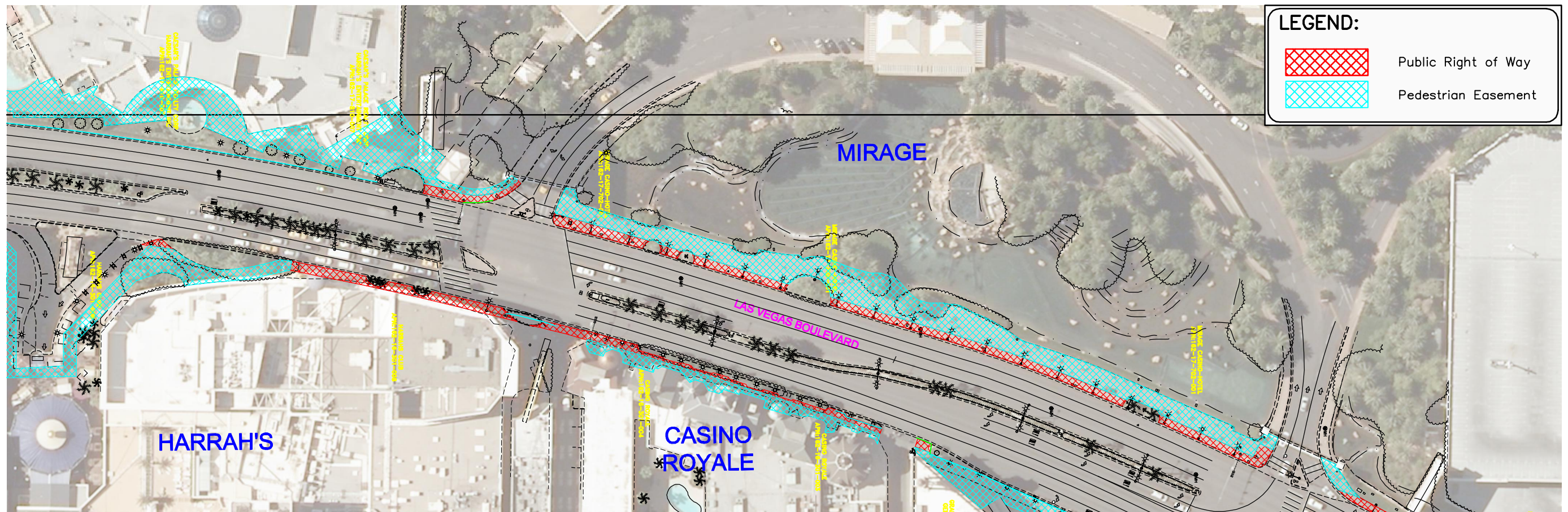
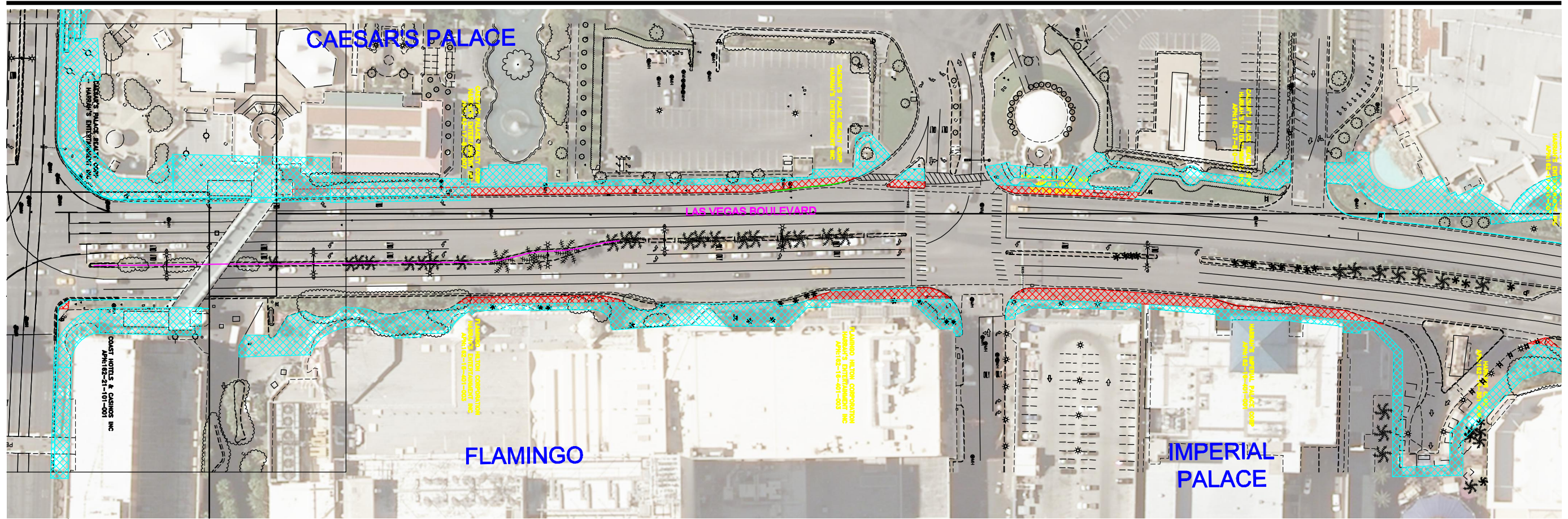

LEGEND:

	Public Right of Way
	Pedestrian Easement



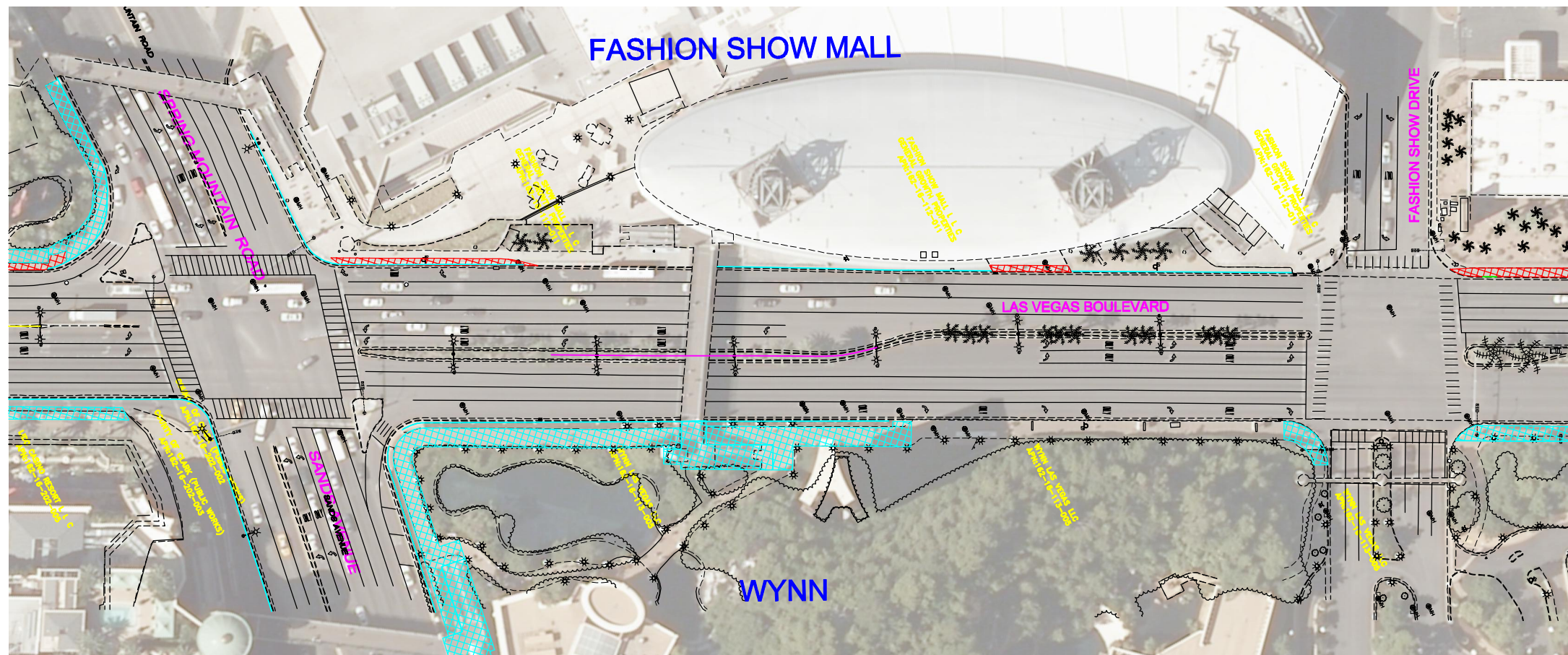
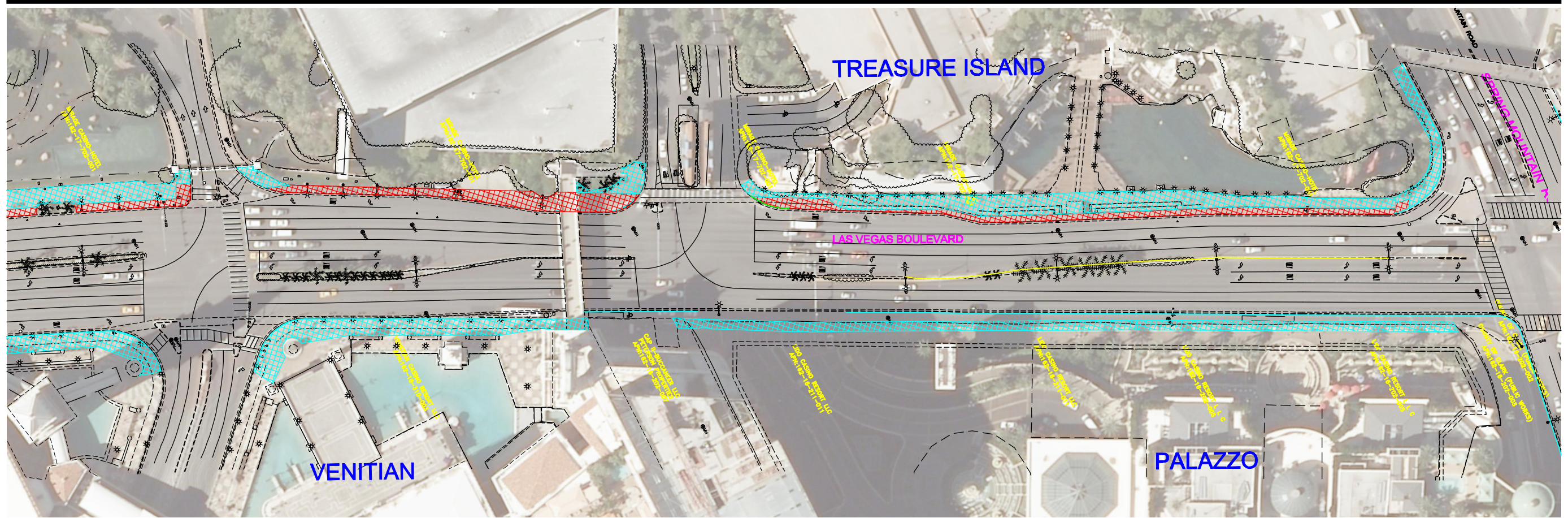

LEGEND:

	Public Right of Way
	Pedestrian Easement



LEGEND:

	Public Right of Way
	Pedestrian Easement

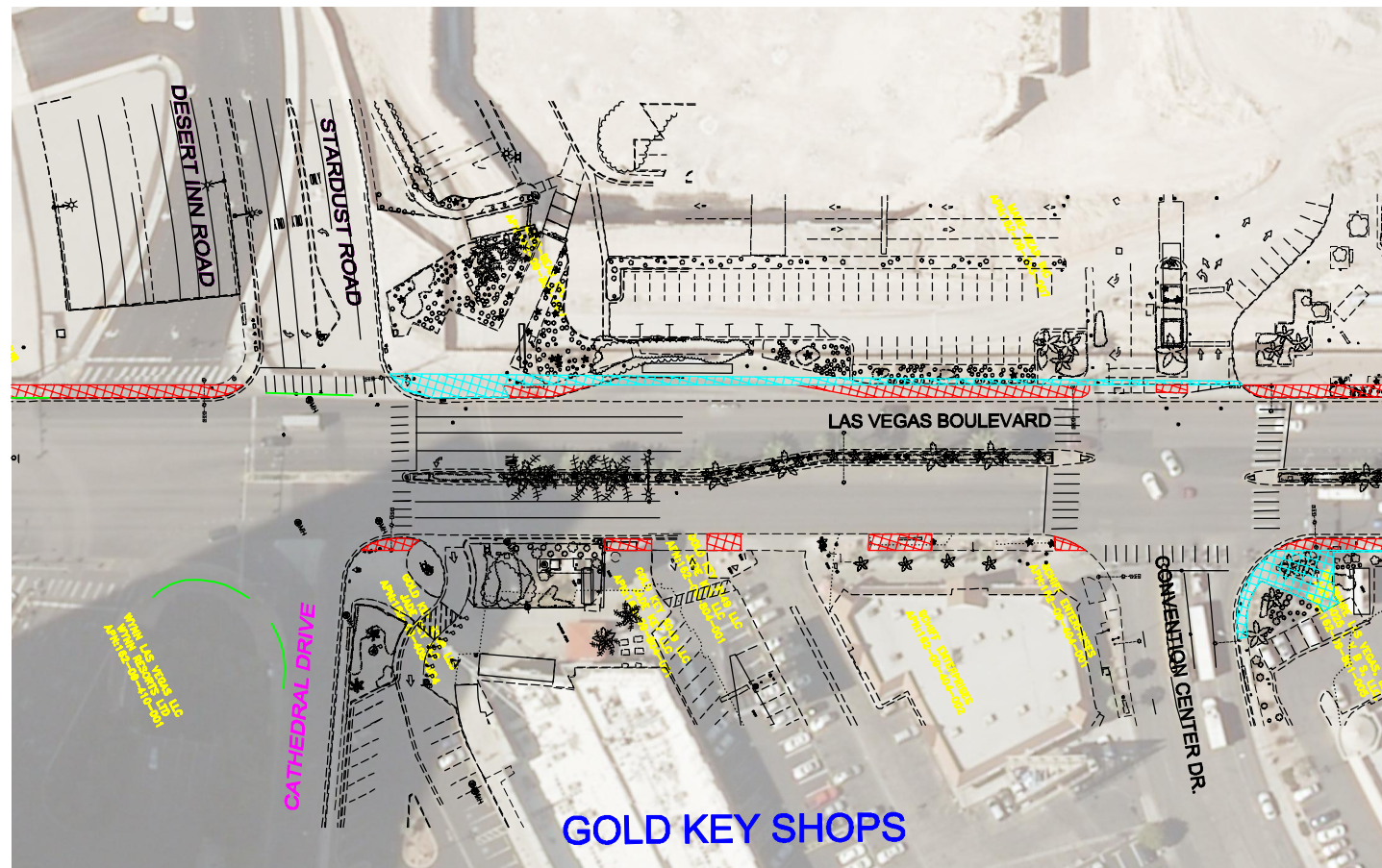
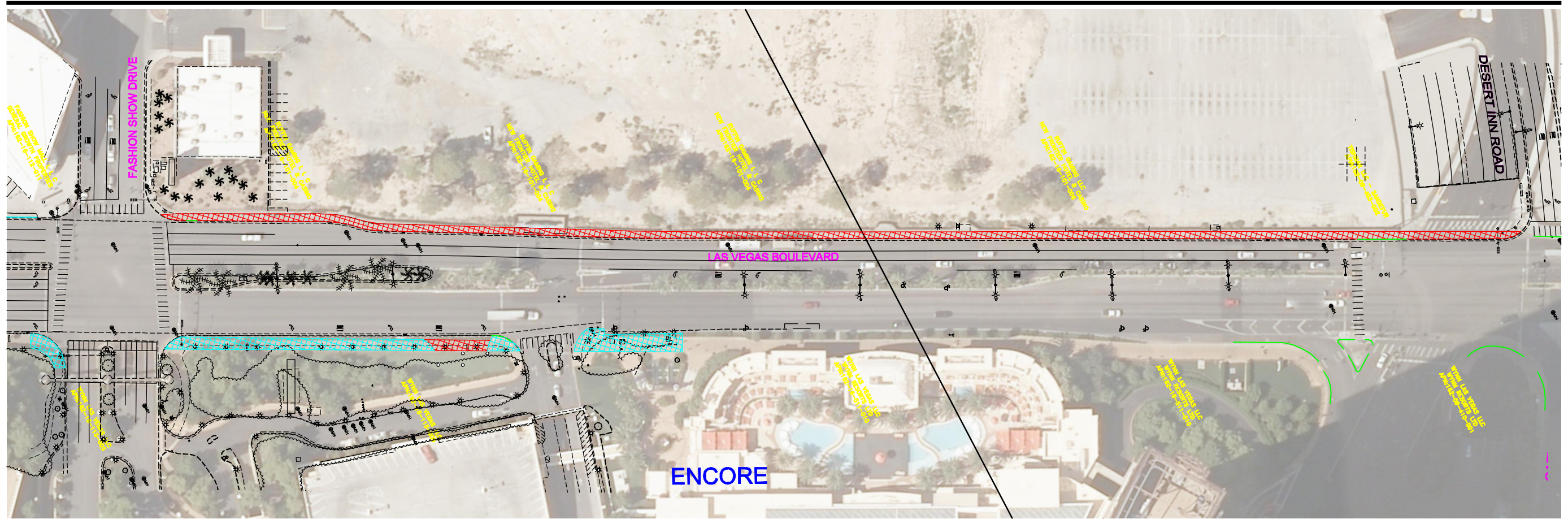

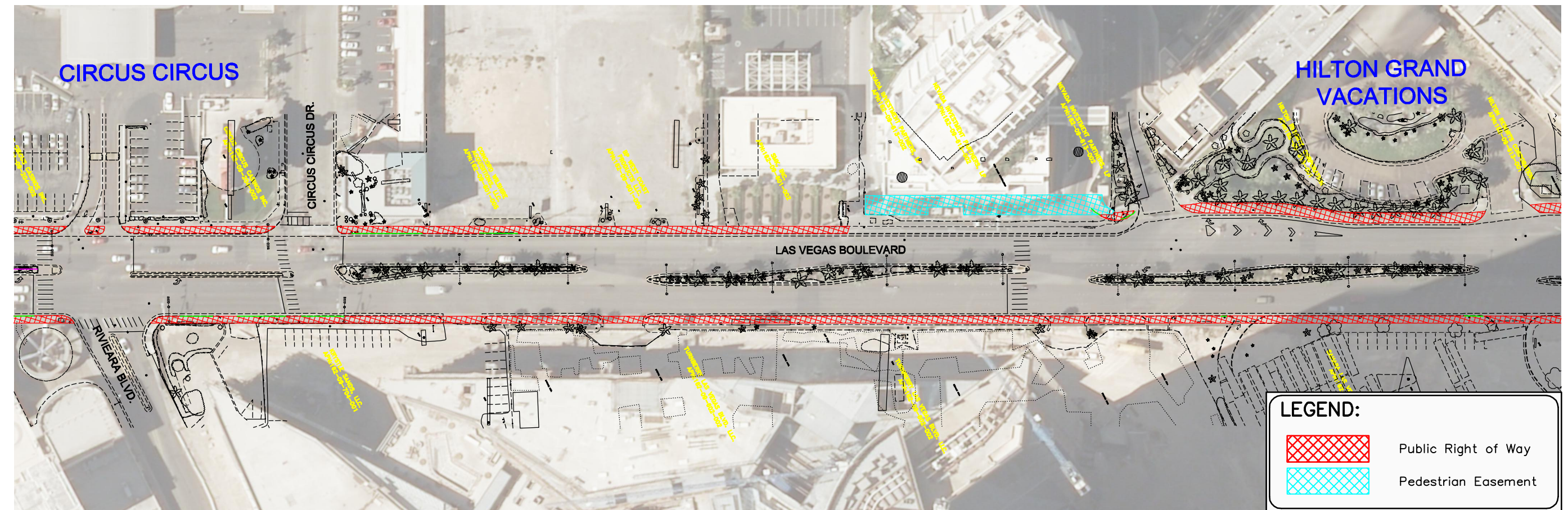
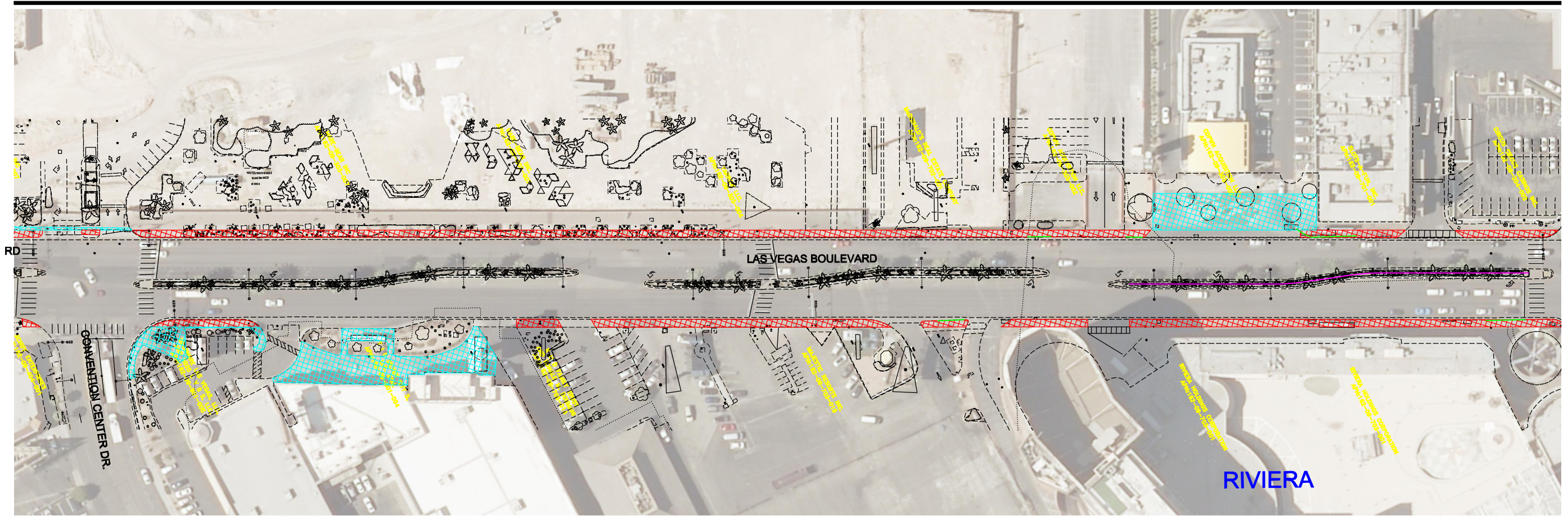

LEGEND:

	Public Right of Way
	Pedestrian Easement



LEGEND:

	Public Right of Way
	Pedestrian Easement

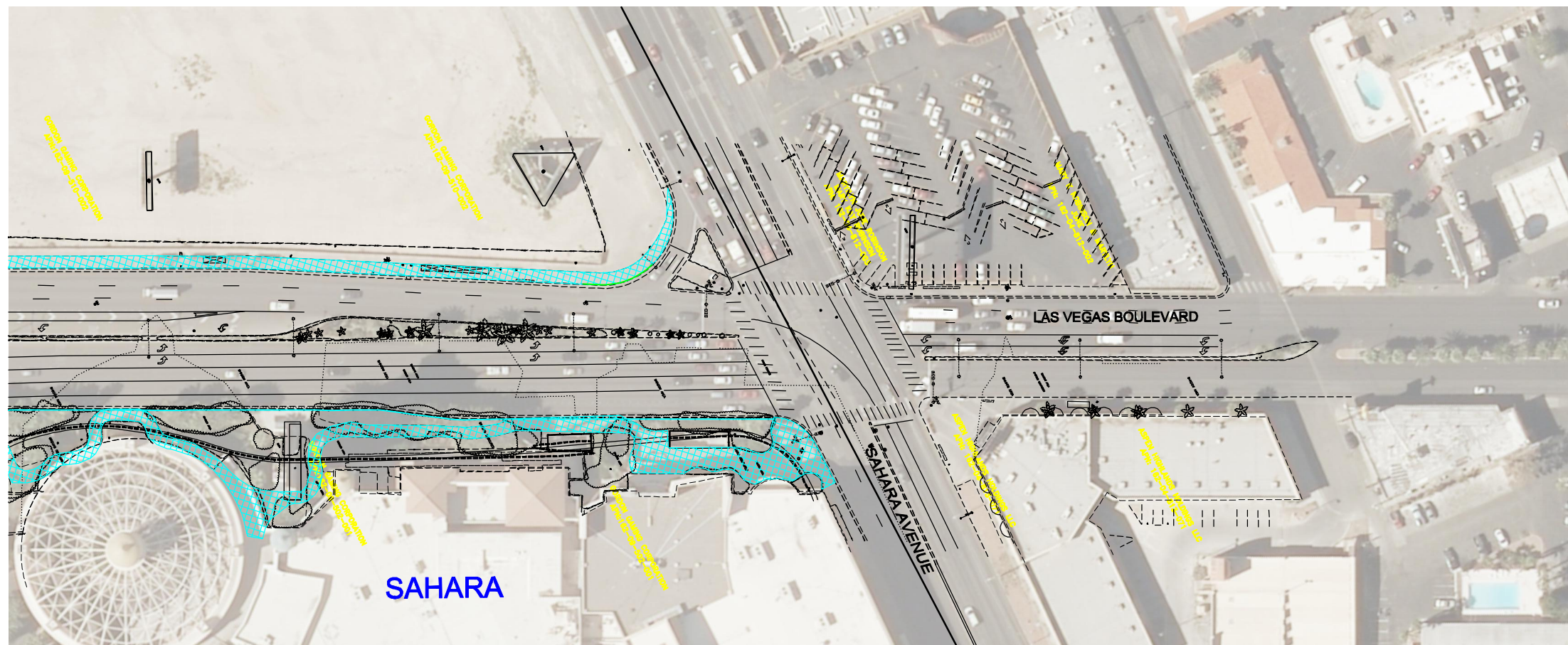
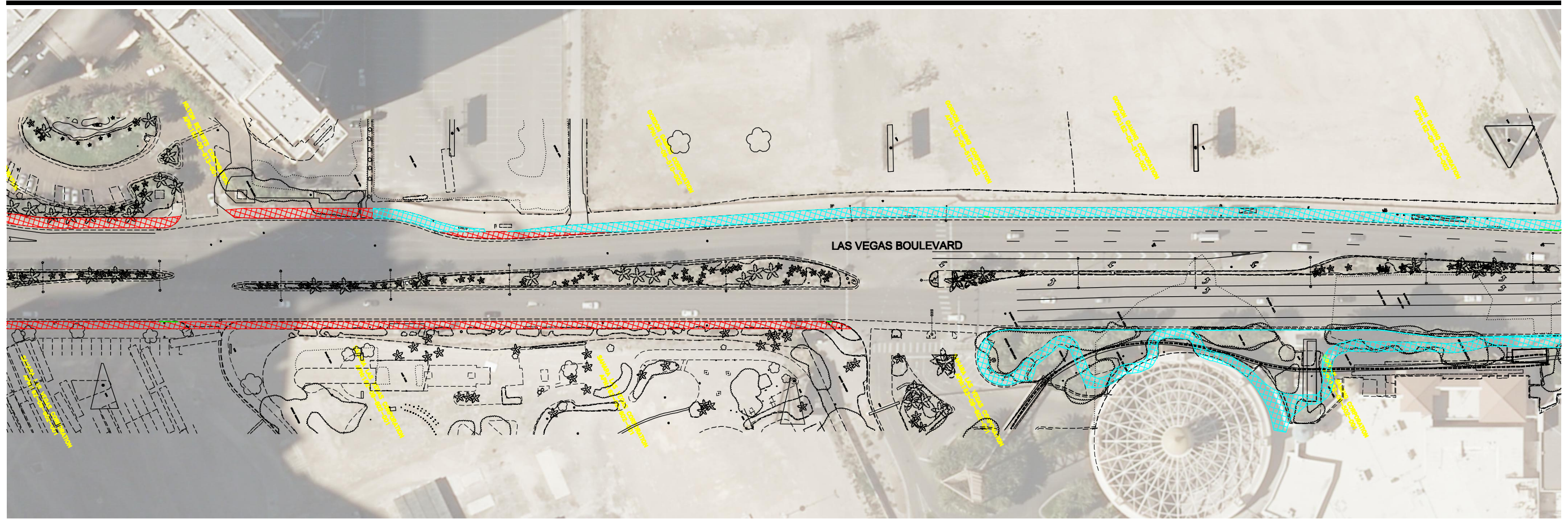

LEGEND:



	Public Right of Way
	Pedestrian Easement

EXHIBIT B

DEPARTMENT OF PUBLIC WORKS



Vicinity Map
NOT TO SCALE

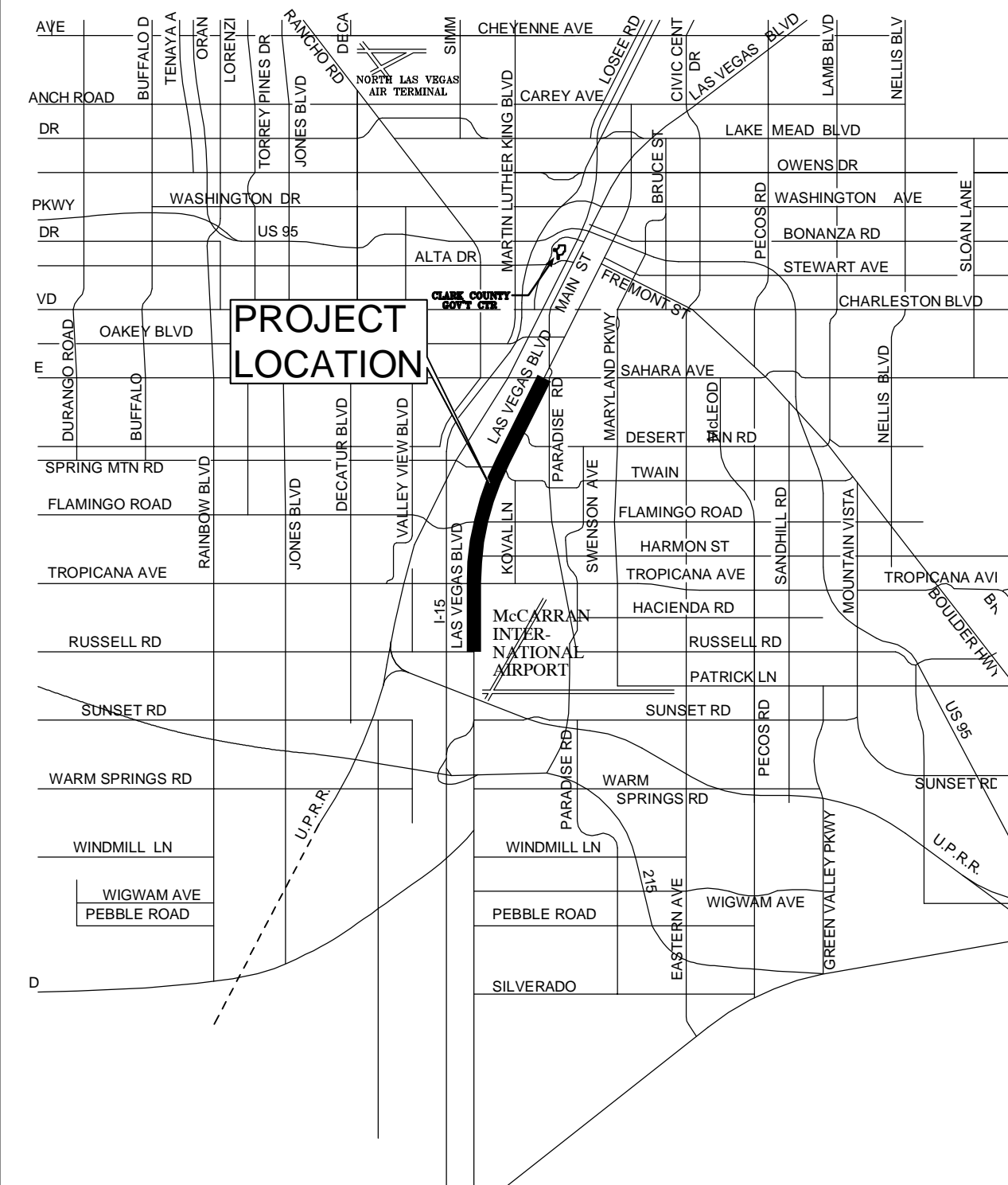

2012

PEDESTRIAN STUDY LAS VEGAS BOULEVARD

County Commissioners

Susan Brager, Chair
Steve Sisolak, Vice Chair
Larry Brown
Tom Collins
Chris Giunchigliani
Mary Beth Scow
Lawrence Weekly

RUSSELL ROAD TO SAHARA AVENUE

FUNDED BY
CLARK COUNTY PUBLIC WORKS

County Manager

Donald G. Burnette

Director of Public Works

Approved:

Denis Cederburg

Index of Sheets

SHEET No.	DWG No.	SHEET NAME
1	GN-1	COVER SHEET
2	GN-2	SHEET INDEX
3 - 4	D-1 - D-2	DETAILS
5 - 24	C-1 - C-20	UPDATED NO OBSTRUCTIVE USE DRAWINGS

AGENCY	PLANS REVIEWED BY	DATE	DEPARTMENT OF PUBLIC WORKS	BY	DATE	REVISIONS			PRELIMINARY DRAWINGS	TRAFFIC MANAGEMENT DIVISION
						NUMBER	DESCRIPTION	DATE		
									90% FOR REVIEW	COVER SHEET
										L-1969

Date: November 17, 2012 - 2:32pm / User: devin.moore
 Path: K:\LAV_PublicTrans\092061019 - Clark County Strip Ped Study\CADD\Plan Sheets\092061019_KM.dwg / Xref: X092061019_TB;X092061019_Reinforcement_Line;X092061019_TopofGrade;X092061019_CityCenter_MP-010
 This document, together with the concepts and designs presented herein, is intended only for the specific purpose and client for which it was prepared. Release of any information contained herein without written authorization and approval by Kimley-Horn and Associates, Inc. shall be without liability to Kimley-Horn and Associates, Inc.

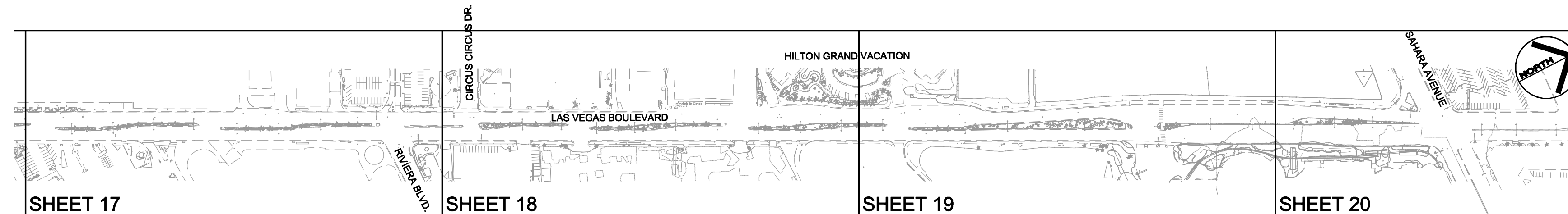
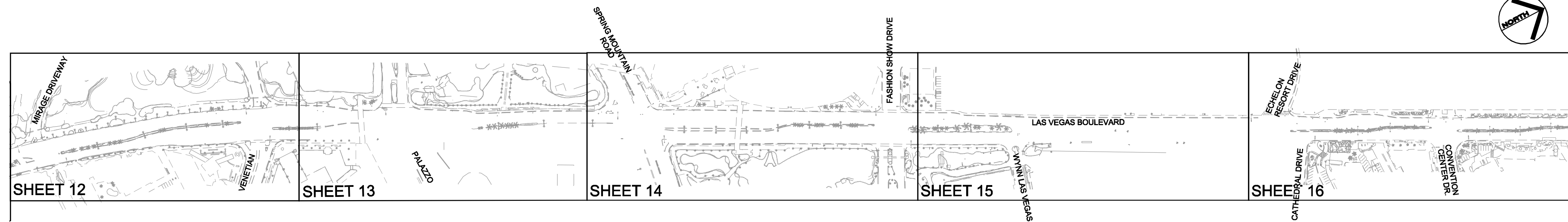
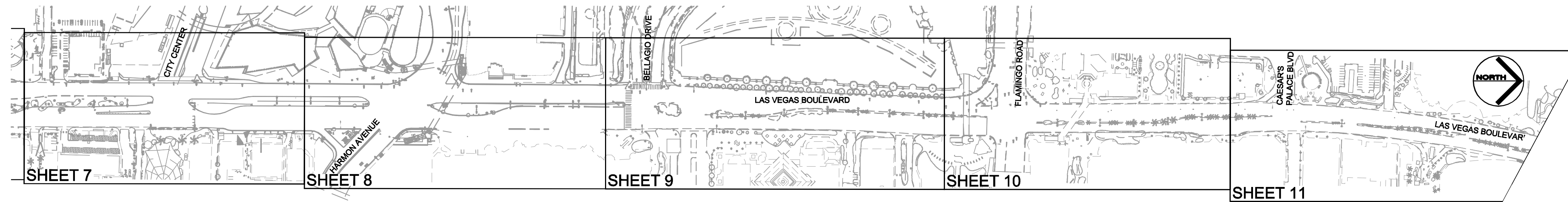
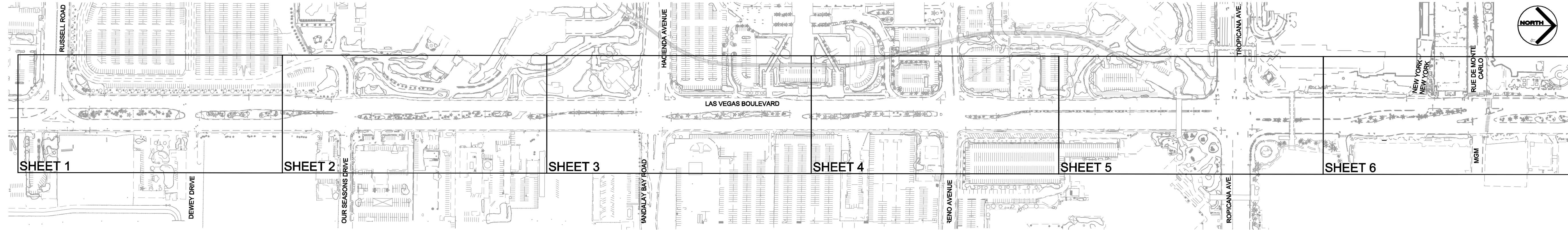

PEDESTRIAN STUDY - LAS VEGAS BLVD
 UPDATED NO OBSTRUCTIVE USE DRAWINGS
 RUSSELL ROAD TO SAHARA AVENUE
 CLARK COUNTY, NEVADA, DEPARTMENT OF PUBLIC WORKS

PRELIMINARY DRAWINGS
90%
 FOR REVIEW

DESIGNED BY: SRA
 DRAWN BY: SAS
 CHECKED BY: KWA
 DATE: Nov 17, 2012 - 2:32pm

SCALE
 HORIZ: AS SHOWN
 VERT: N/A
 FIELD BOOK: NONE

SHEET No
GN-2
 SHEET 2 OF 24

APPROVED

Date: November 17, 2012 - 2:32pm / User: devin.moore
 Path: K:\LAJ_PublicTrans\092061019 - Clark County Strip Ped Study\CADD\Plan Sheets\092061019_DT.dwg / Xref: X092061019_TB
 This document, together with the concepts and designs presented herein, is intended only for the specific purpose and client for which it was prepared. Release of and improper reliance on this document without written authorization and adaptation by Kinship-Horn and Associates, Inc. shall be without liability to Kinship-Horn and Associates, Inc.

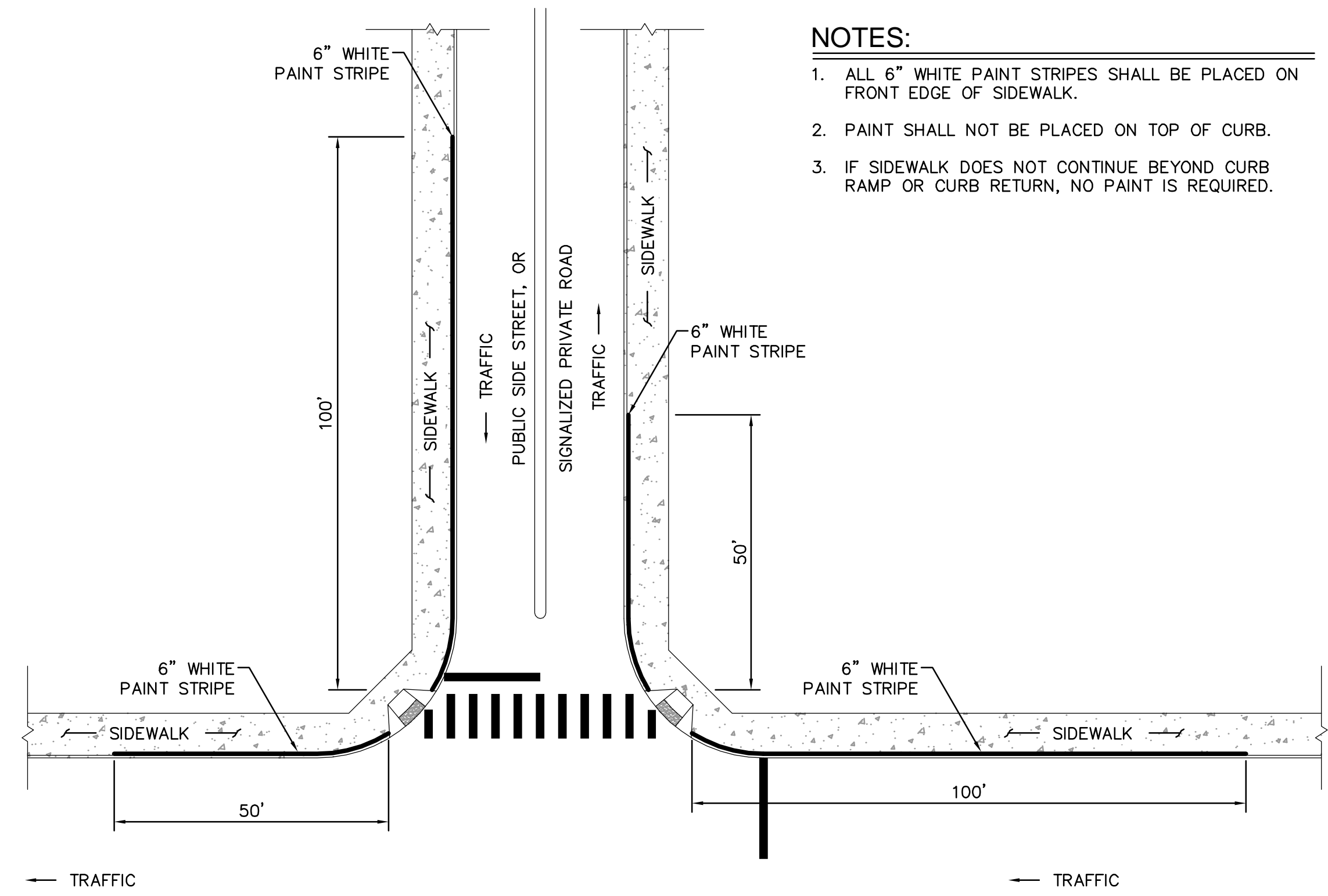

- NOTES:**
1. ALL 6" WHITE PAINT STRIPES SHALL BE PLACED ON FRONT EDGE OF SIDEWALK.
 2. PAINT SHALL NOT BE PLACED ON TOP OF CURB.
 3. IF SIDEWALK DOES NOT CONTINUE BEYOND CURB RAMP OR CURB RETURN, NO PAINT IS REQUIRED.

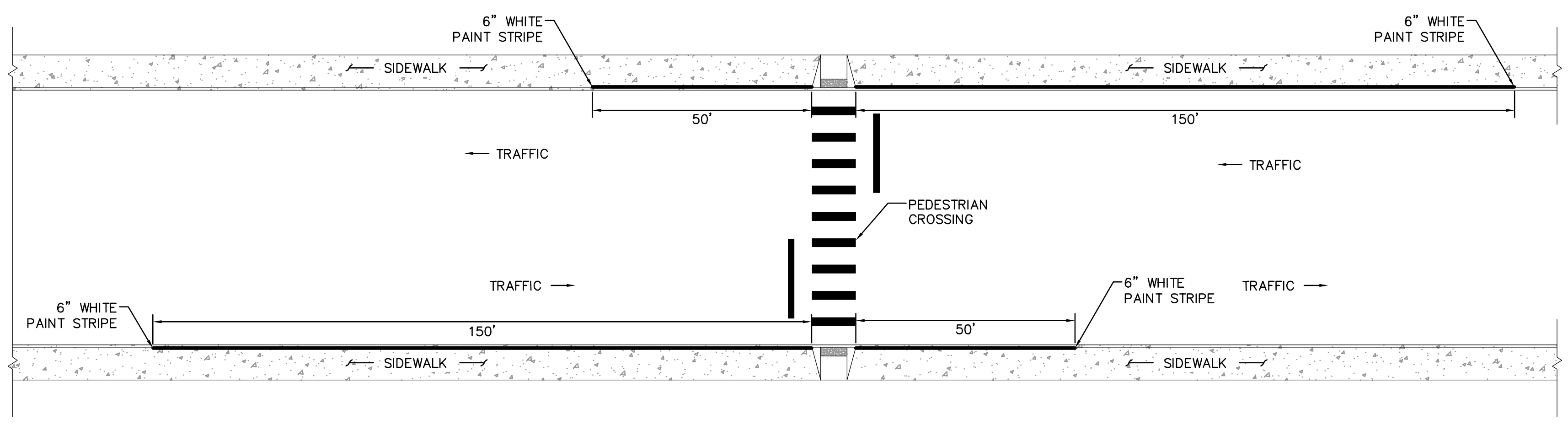

MID-BLOCK CROSSING

PUBLIC STREETS AND SIGNALIZED PRIVATE ROADS

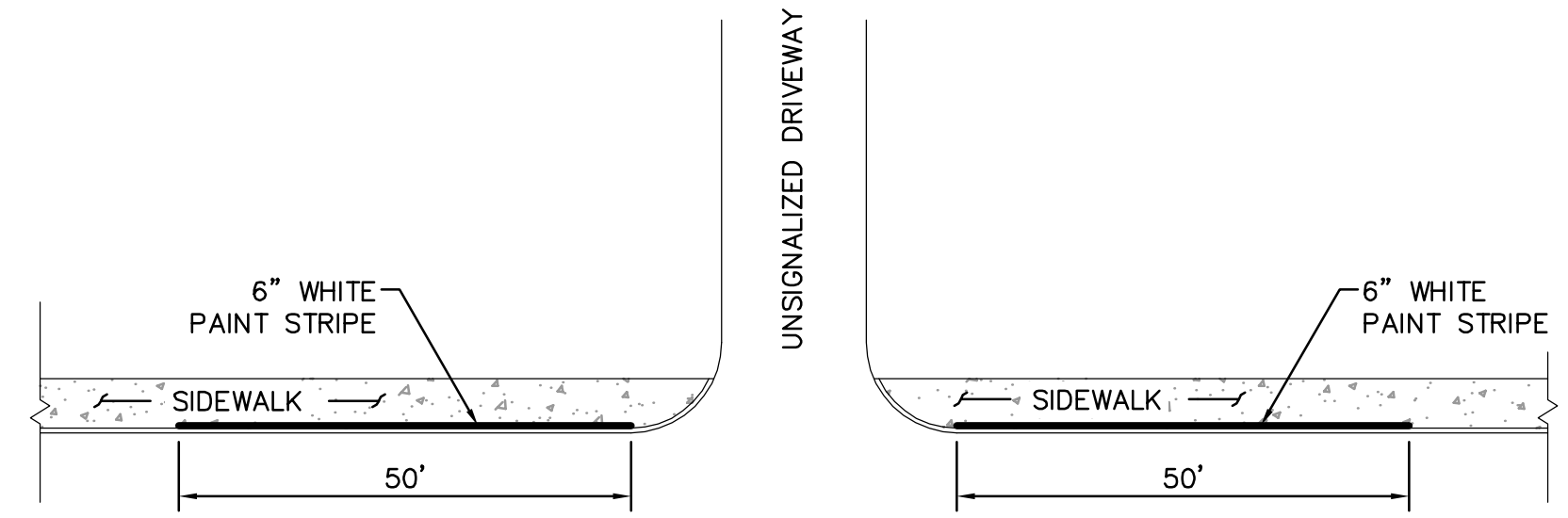

UNSIGNALIZED DRIVEWAY

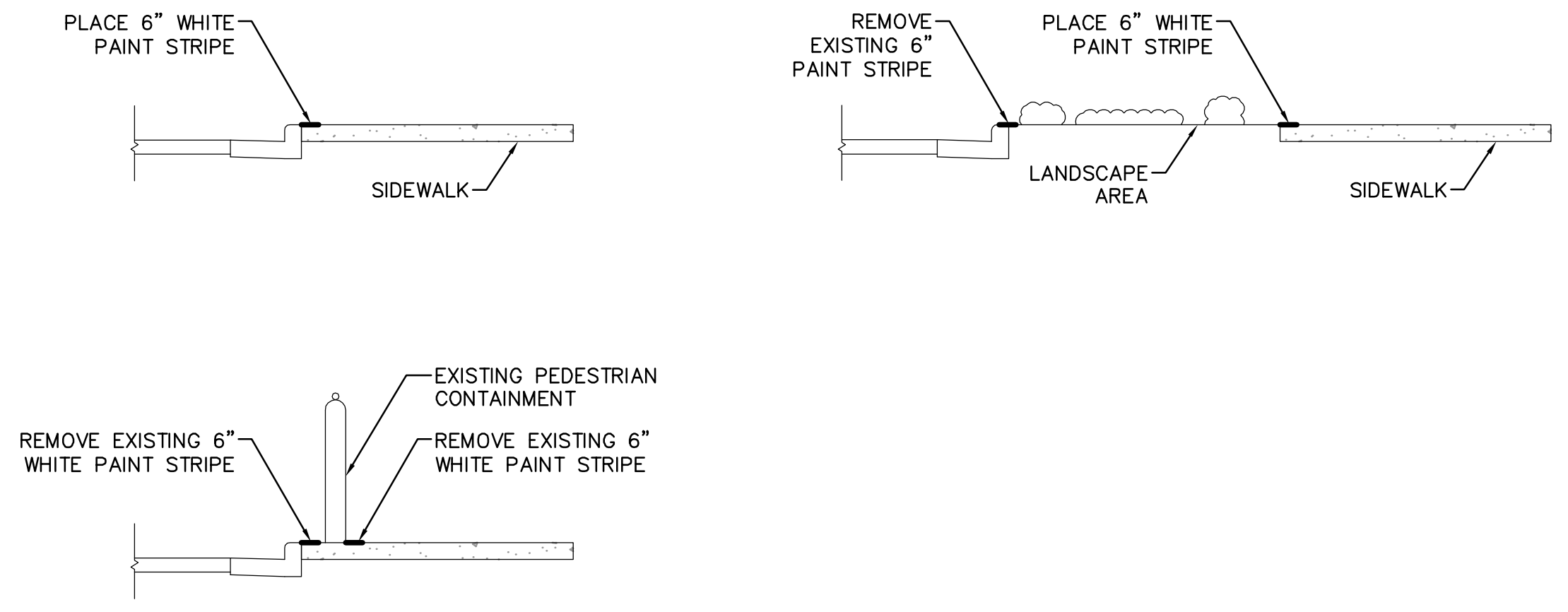

TYPICAL PAINT STRIPE LOCATIONS

APPROVED



PEDESTRIAN STUDY - LAS VEGAS BLVD
 UPDATED NO OBSTRUCTIVE USE DRAWINGS
 RUSSELL ROAD TO SAHARA AVENUE
 CLARK COUNTY, NEVADA, DEPARTMENT OF PUBLIC WORKS

PRELIMINARY DRAWINGS
90%
 FOR REVIEW

DESIGNED BY: SRA
 DRAWN BY: SAS
 CHECKED BY: KWA
 DATE: Nov 17, 2012 - 2:32pm

SCALE
 HORIZ: AS SHOWN
 VERT: N/A
 FIELD BOOK NONE

SHEET No
D-1
 SHEET 3 OF 24

Date: November 17, 2012 - 2:32pm / User: devin.moore
 Path: K:\AJV_Public\Trans\092061019 - Clark County Strip Ped Study\CADD\Plan Sheets\092061019_DT.dwg / Xref: X092061019_TB
 This document, together with the concepts and designs presented herein, is intended only for the specific purpose and client for which it was prepared. Please do not make any reproduction or adaptation without written authorization and approval by Kimmey-Horn and Associates, Inc. and be without liability to Kimmey-Horn and Associates, Inc.

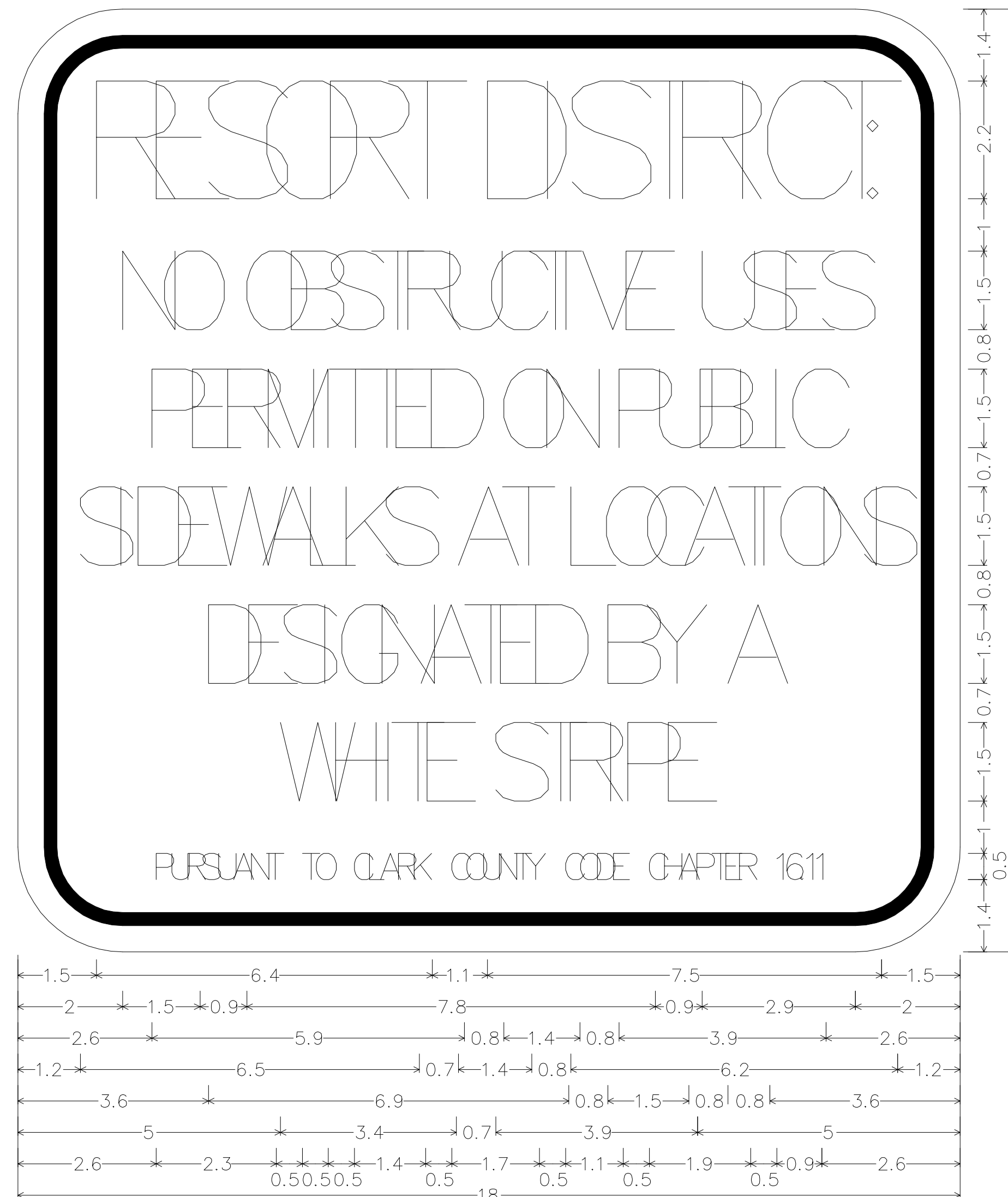

ORDINANCE SIGN DETAIL

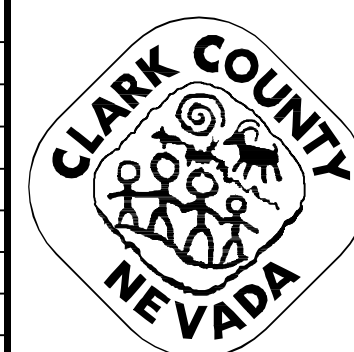

PEDESTRIAN STUDY - LAS VEGAS BLVD
 UPDATED NO OBSTRUCTIVE USE DRAWINGS
 RUSSELL ROAD TO SAHARA AVENUE
 CLARK COUNTY, NEVADA, DEPARTMENT OF PUBLIC WORKS

PRELIMINARY DRAWINGS
90%
 FOR REVIEW

DESIGNED BY: SRA
 DRAWN BY: SAS
 CHECKED BY: KWA
 DATE: Nov 17, 2012 - 2:32pm

SCALE
 HORIZ: AS SHOWN
 VERT: N/A
 FIELD BOOK: NONE

SHEET No
D-2
 SHEET 4 OF 24

APPROVED

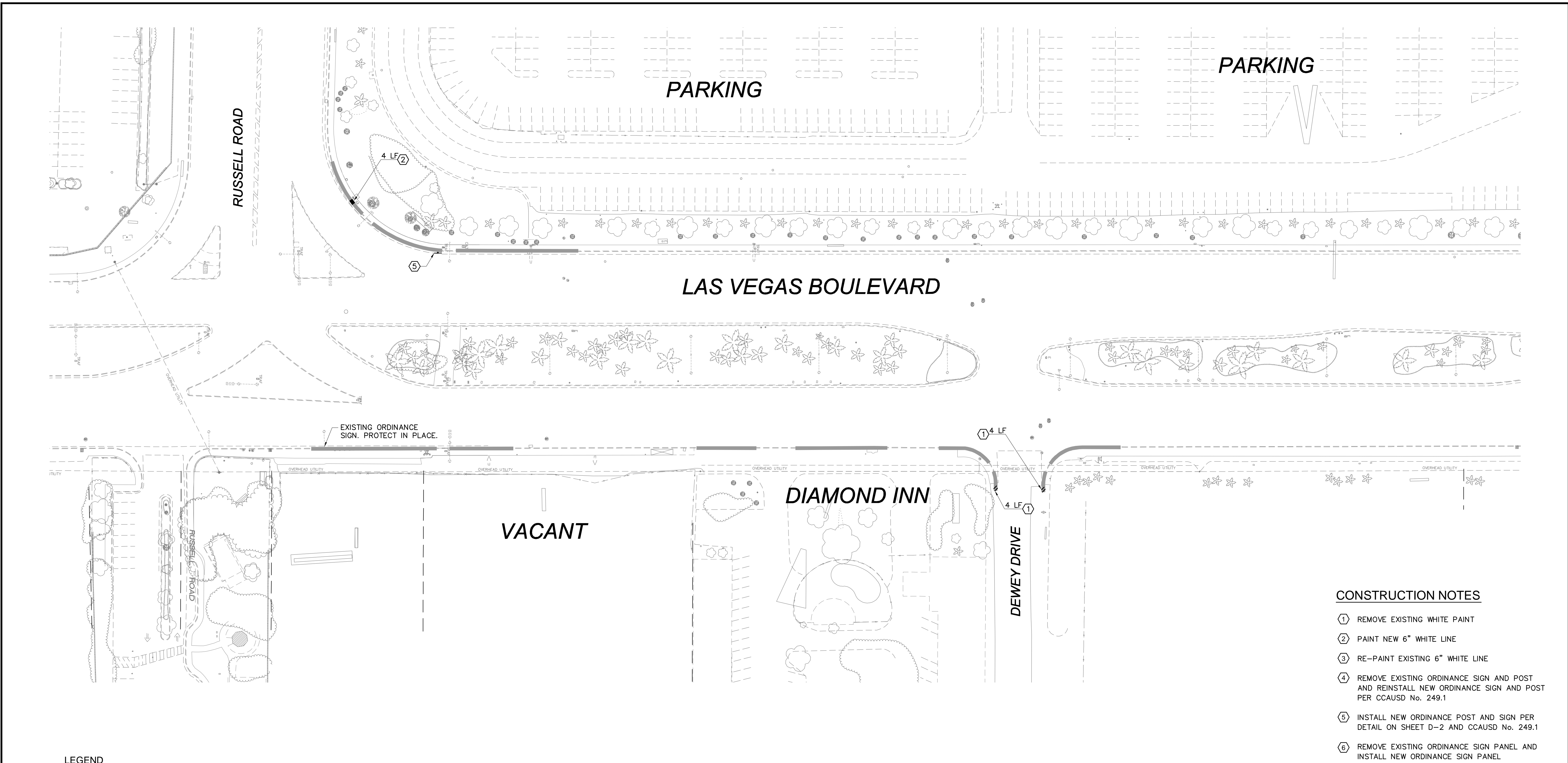

- CONSTRUCTION NOTES**
- ① REMOVE EXISTING WHITE PAINT
 - ② PAINT NEW 6" WHITE LINE
 - ③ RE-PAINT EXISTING 6" WHITE LINE
 - ④ REMOVE EXISTING ORDINANCE SIGN AND POST AND REINSTALL NEW ORDINANCE SIGN AND POST PER CCAUSD No. 249.1
 - ⑤ INSTALL NEW ORDINANCE POST AND SIGN PER DETAIL ON SHEET D-2 AND CCAUSD No. 249.1
 - ⑥ REMOVE EXISTING ORDINANCE SIGN PANEL AND INSTALL NEW ORDINANCE SIGN PANEL

LEGEND

	EXISTING TOP OF CURB WHITE LINE
	INSTALL 6" TOP OF CURB WHITE LINE
	REMOVE EXISTING TOP OF CURB WHITE LINE
	INACTIVE DRIVEWAY

NOTE:
PROTECT EXISTING 6" WHITE LINE UNLESS NOTED OTHERWISE

NOTE:
TOPOGRAPHIC INFORMATION SHOWN ON THESE PLANS WAS DEVELOPED BASED ON A SEARCH OF BEST AVAILABLE RECORDS AND INFORMATION. LOCATIONS AND CONDITION OF IMPROVEMENTS SHOWN ARE SUBJECT TO CHANGE AND SHALL BE VERIFIED IN THE FIELD.

BENCHMARK
NO SURVEY

BASIS OF BEARING
NO SURVEY

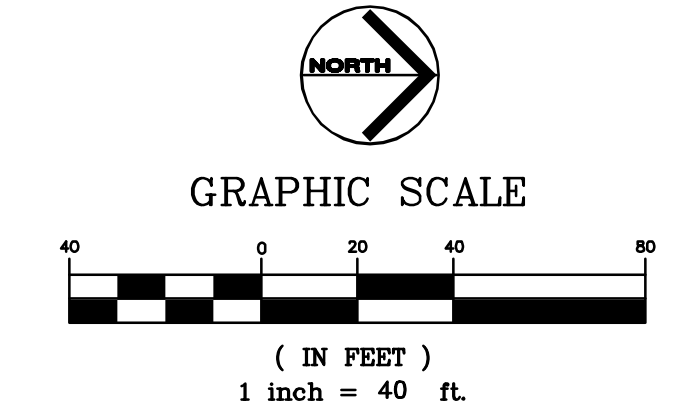

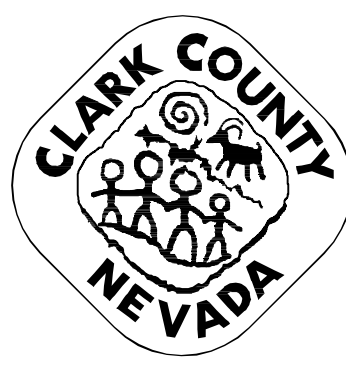

PEDESTRIAN STUDY - LAS VEGAS BLVD
 UPDATED NO OBSTRUCTIVE USE DRAWINGS
 RUSSELL ROAD TO SAHARA AVENUE
 CLARK COUNTY, NEVADA, DEPARTMENT OF PUBLIC WORKS

PRELIMINARY DRAWINGS
90%
 FOR REVIEW

DESIGNED BY:	SRA
DRAWN BY:	SAS
CHECKED BY:	KWA
DATE:	Nov 17, 2012 - 3:45pm



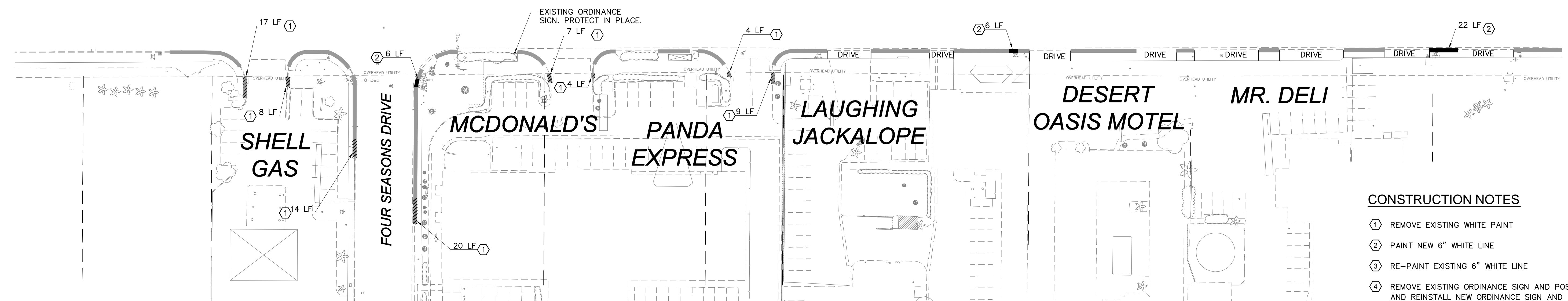
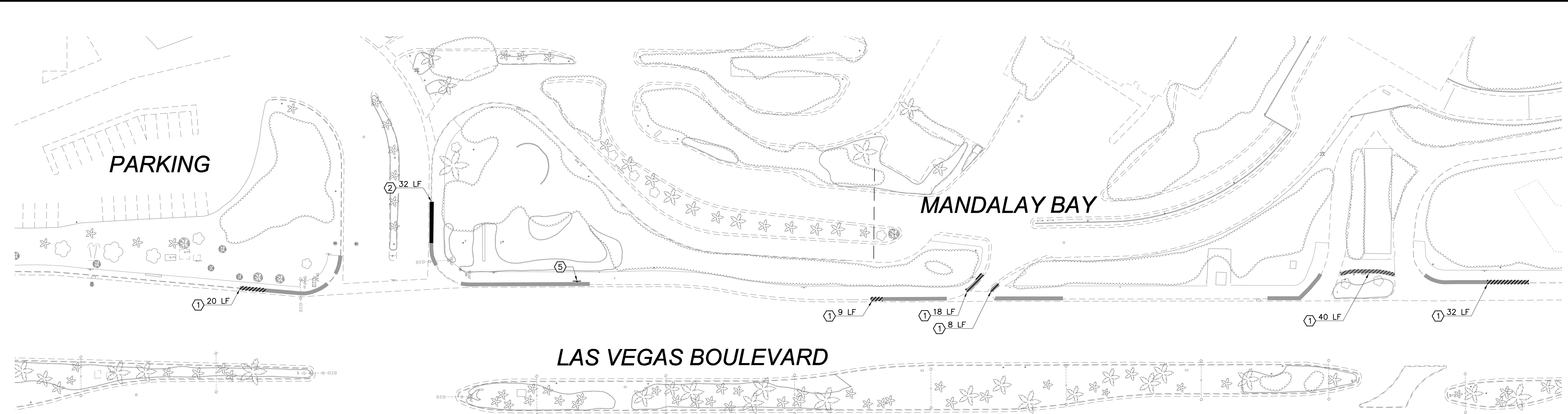

SCALE	
HORIZ:	AS SHOWN
VERT:	N/A
FIELD BOOK	NONE

SHEET No
C-1
SHEET 5 OF 24

Date: November 17, 2012 - 2:32pm / User: devin.moore
 Path: K:\AV_PublicTrans\092061019 - Clark County Strip Ped Study\CADD\Plan Sheets\092061019_Russell to Trop Jan 09.dwg / Xref: X092061019_TB_X092061019_AE_2011_RusselltoTropicana.dwg
 Drawing Encore Offices: Palazzo entrance; X092061019_XCityCenter_MP-010; X092061019_WhiteHillmen
 This document, together with the concepts and designs presented herein, is intended only for the specific purpose and client for which it was prepared. Plans of any improvement shown are subject to change and shall be verified in the field.



LEGEND

	EXISTING TOP OF CURB WHITE LINE
	INSTALL 6" TOP OF CURB WHITE LINE
	REMOVE EXISTING TOP OF CURB WHITE LINE
	INACTIVE DRIVEWAY

NOTE:
PROTECT EXISTING 6" WHITE LINE UNLESS NOTED OTHERWISE

NOTE:
TOPOGRAPHIC INFORMATION SHOWN ON THESE PLANS WAS DEVELOPED
BASED ON A SEARCH OF BEST AVAILABLE RECORDS AND INFORMATION.
LOCATIONS AND CONDITION OF IMPROVEMENTS SHOWN ARE SUBJECT TO
CHANGE AND SHALL BE VERIFIED IN THE FIELD.

- CONSTRUCTION NOTES**
- ① REMOVE EXISTING WHITE PAINT
 - ② PAINT NEW 6" WHITE LINE
 - ③ RE-PAINT EXISTING 6" WHITE LINE
 - ④ REMOVE EXISTING ORDINANCE SIGN AND POST AND REINSTALL NEW ORDINANCE SIGN AND POST PER CCAUSD No. 249.1
 - ⑤ INSTALL NEW ORDINANCE POST AND SIGN PER DETAIL ON SHEET D-2 AND CCAUSD No. 249.1
 - ⑥ REMOVE EXISTING ORDINANCE SIGN PANEL AND INSTALL NEW ORDINANCE SIGN PANEL

BENCHMARK
NO SURVEY

BASIS OF BEARING
NO SURVEY

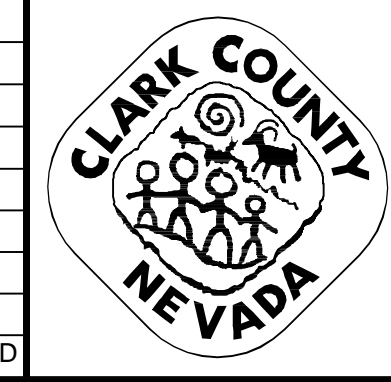
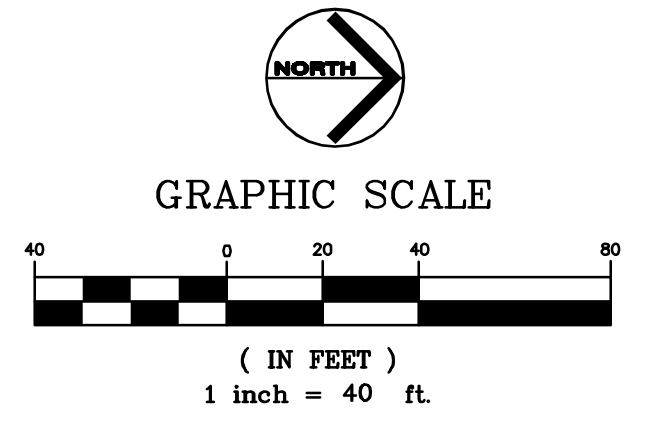

PEDESTRIAN STUDY - LAS VEGAS BLVD
 UPDATED NO OBSTRUCTIVE USE DRAWINGS
 RUSSELL ROAD TO SAHARA AVENUE
 CLARK COUNTY, NEVADA, DEPARTMENT OF PUBLIC WORKS

PRELIMINARY DRAWINGS

90%

FOR REVIEW

DESIGNED BY: SRA
 DRAWN BY: SAS
 CHECKED BY: KWA
 DATE: Nov 17, 2012 - 2:32pm

SCALE	
HORIZ:	AS SHOWN
VERT:	N/A
FIELD BOOK	NONE

SHEET No

C-2

SHEET 6 OF 24

APPROVED

Date: November 17, 2012 - 2:32pm / User: devin.moore
 Path: K:\LV_Public\Trans\092061019 - Clark County Strip Ped Study\CADD\Plan Sheets\092061019_Russell to Trop Jan 09.dwg / Xref: X092061019_TB_X092061019_Topographic.dwg
 This document, together with the concepts and designs presented herein, is intended only for the specific purpose and client for which it was prepared. Plans of any improvement or adaptation by Employment and Associates, Inc. shall be without liability to Employment and Associates, Inc.

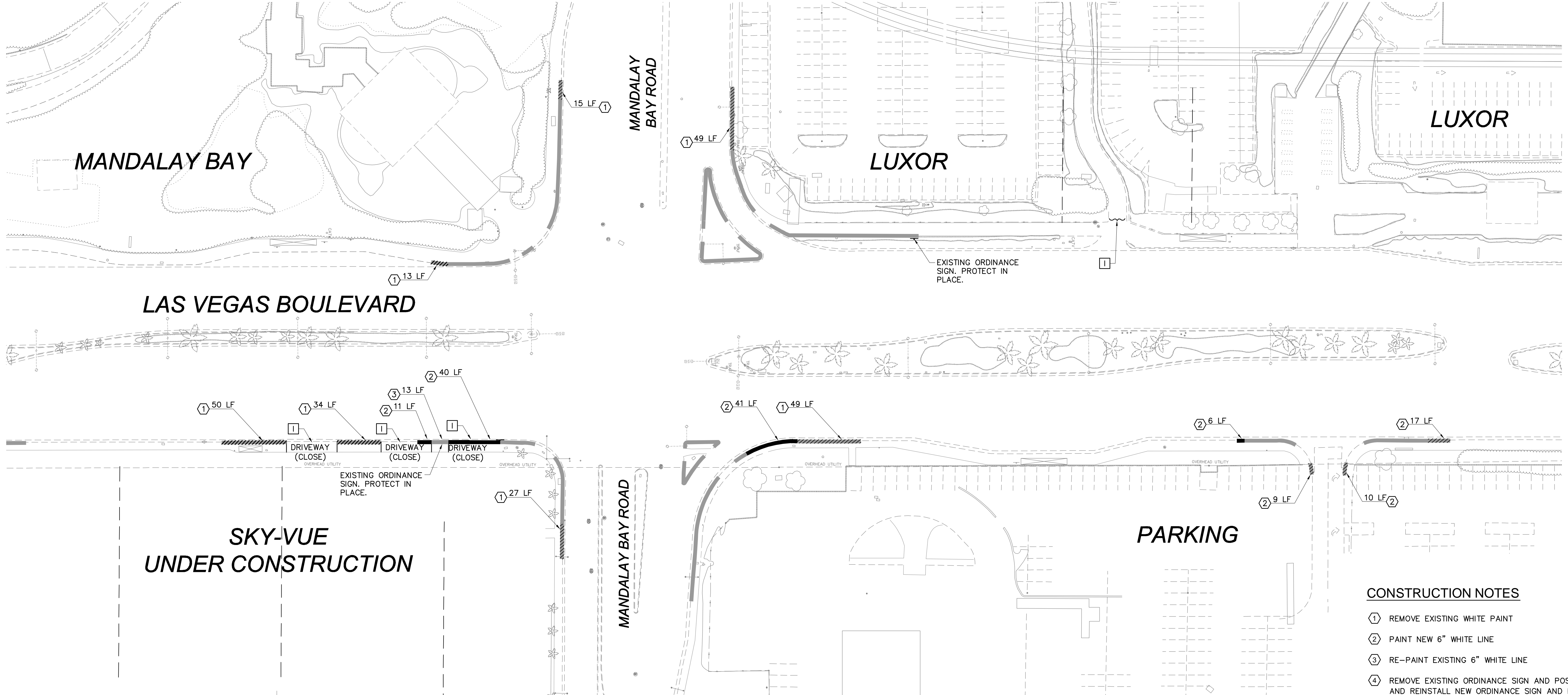

LEGEND

	EXISTING TOP OF CURB WHITE LINE
	INSTALL 6" TOP OF CURB WHITE LINE
	REMOVE EXISTING TOP OF CURB WHITE LINE
	INACTIVE DRIVEWAY

- CONSTRUCTION NOTES**
- ① REMOVE EXISTING WHITE PAINT
 - ② PAINT NEW 6" WHITE LINE
 - ③ RE-PAINT EXISTING 6" WHITE LINE
 - ④ REMOVE EXISTING ORDINANCE SIGN AND POST AND REINSTALL NEW ORDINANCE SIGN AND POST PER CCAUSD No. 249.1
 - ⑤ INSTALL NEW ORDINANCE POST AND SIGN PER DETAIL ON SHEET D-2 AND CCAUSD No. 249.1
 - ⑥ REMOVE EXISTING ORDINANCE SIGN PANEL AND INSTALL NEW ORDINANCE SIGN PANEL

NOTE:
PROTECT EXISTING 6" WHITE LINE UNLESS NOTED OTHERWISE

NOTE:
TOPOGRAPHIC INFORMATION SHOWN ON THESE PLANS WAS DEVELOPED BASED ON A SEARCH OF BEST AVAILABLE RECORDS AND INFORMATION. LOCATIONS AND CONDITION OF IMPROVEMENTS SHOWN ARE SUBJECT TO CHANGE AND SHALL BE VERIFIED IN THE FIELD.

BENCHMARK
NO SURVEY

BASIS OF BEARING
NO SURVEY

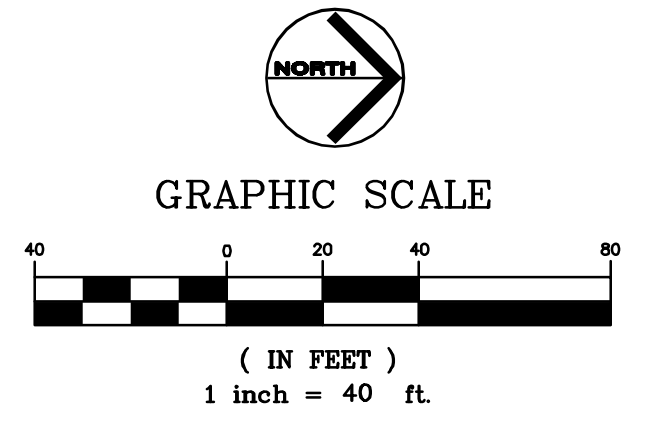

PEDESTRIAN STUDY - LAS VEGAS BLVD
 UPDATED NO OBSTRUCTIVE USE DRAWINGS
 RUSSELL ROAD TO SAHARA AVENUE
 CLARK COUNTY, NEVADA, DEPARTMENT OF PUBLIC WORKS

PRELIMINARY DRAWINGS
90%
 FOR REVIEW

DESIGNED BY:	SRA
DRAWN BY:	SAS
CHECKED BY:	KWA
DATE:	Nov 17, 2012 - 2:32pm

SCALE	HORIZ: AS SHOWN
	VERT: N/A
FIELD BOOK	NONE

SHEET No	C-3
	SHEET 7 OF 24

APPROVED

Date: November 17, 2012 - 2:33pm / User: devin.moore
 Path: K:\LAJ_PublicTrans\092061019 - Clark County Strip Ped Study\CADD\Plan Sheets\092061019_Russell to Trop Jan 09.dwg / Xref: X092061019_TB.X092061019_TB.X092061019_Topouptates.D drawing:Encore_Offsites_Palazzo_entrances;X092061019_XCityCenter_MP-010;X092061019_WhiteLines.mxd
 This document, together with the concepts and designs presented herein, is intended only for the specific purpose and client for which it was prepared. Release of any information contained herein without written authorization and approval by Employment and Associates, Inc. shall be without liability to Employment and Associates, Inc.

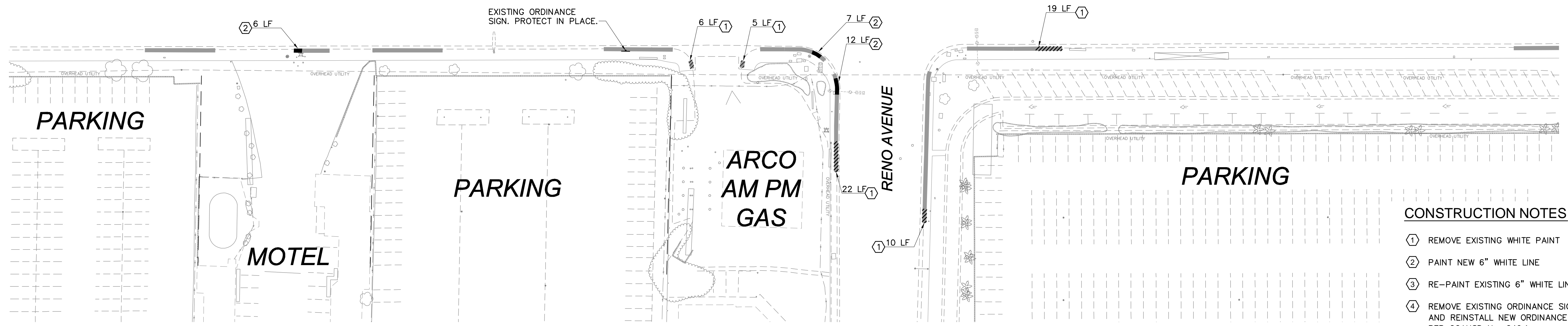
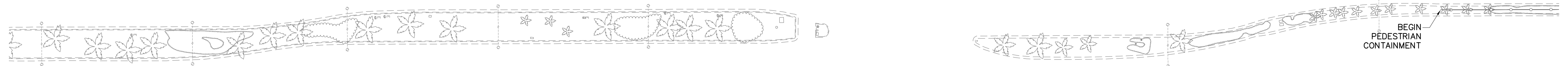
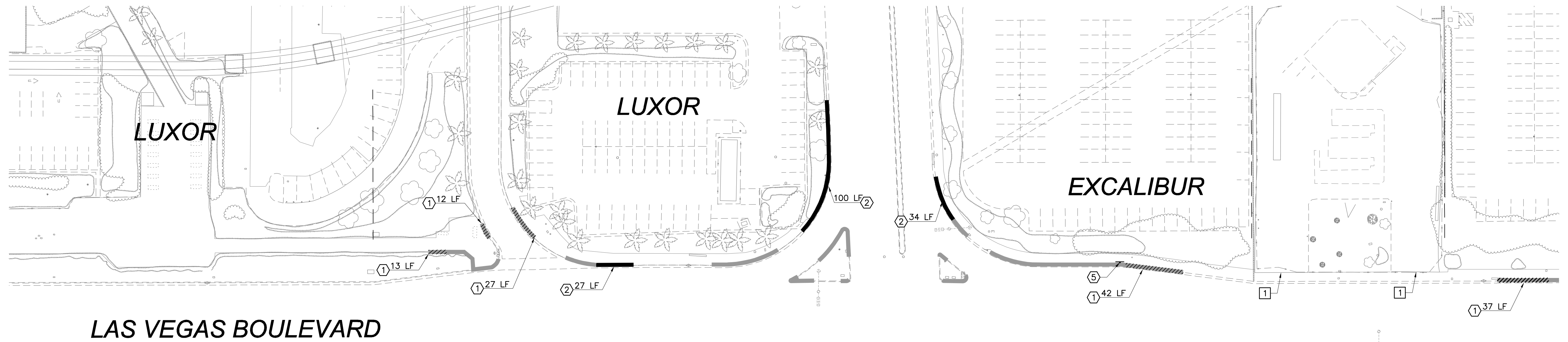

LEGEND

	EXISTING TOP OF CURB WHITE LINE
	INSTALL 6" TOP OF CURB WHITE LINE
	REMOVE EXISTING TOP OF CURB WHITE LINE
	INACTIVE DRIVEWAY

- CONSTRUCTION NOTES**
- ① REMOVE EXISTING WHITE PAINT
 - ② PAINT NEW 6" WHITE LINE
 - ③ RE-PAINT EXISTING 6" WHITE LINE
 - ④ REMOVE EXISTING ORDINANCE SIGN AND POST AND REINSTALL NEW ORDINANCE SIGN AND POST PER CCAUSD No. 249.1
 - ⑤ INSTALL NEW ORDINANCE POST AND SIGN PER DETAIL ON SHEET D-2 AND CCAUSD No. 249.1
 - ⑥ REMOVE EXISTING ORDINANCE SIGN PANEL AND INSTALL NEW ORDINANCE SIGN PANEL

NOTE:
PROTECT EXISTING 6" WHITE LINE UNLESS NOTED OTHERWISE

NOTE:
TOPOGRAPHIC INFORMATION SHOWN ON THESE PLANS WAS DEVELOPED BASED ON A SEARCH OF BEST AVAILABLE RECORDS AND INFORMATION. LOCATIONS AND CONDITION OF IMPROVEMENTS SHOWN ARE SUBJECT TO CHANGE AND SHALL BE VERIFIED IN THE FIELD.

BENCHMARK
NO SURVEY

BASIS OF BEARING
NO SURVEY

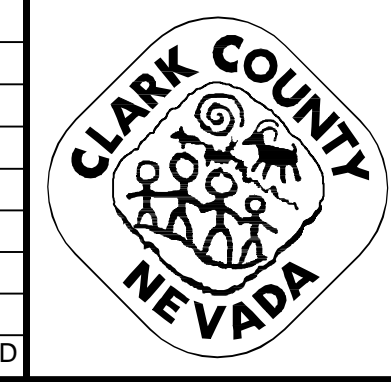
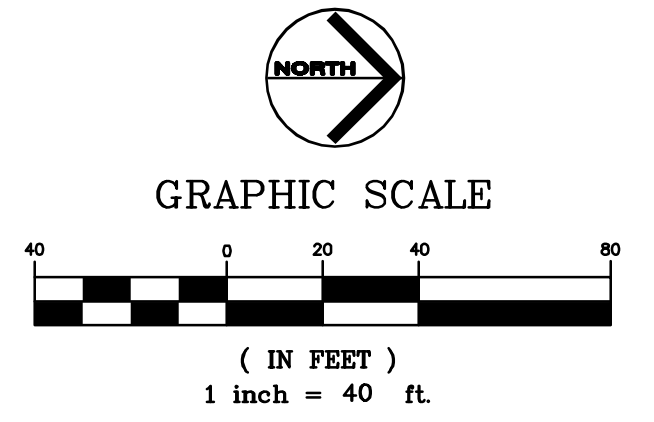

PEDESTRIAN STUDY - LAS VEGAS BLVD
 UPDATED NO OBSTRUCTIVE USE DRAWINGS
 RUSSELL ROAD TO SAHARA AVENUE
 CLARK COUNTY, NEVADA, DEPARTMENT OF PUBLIC WORKS

PRELIMINARY DRAWINGS
90%
 FOR REVIEW

DESIGNED BY:	SRA
DRAWN BY:	SAS
CHECKED BY:	KWA
DATE:	Nov 17, 2012 - 2:33pm

SCALE	
HORIZ:	AS SHOWN
VERT:	N/A
FIELD BOOK	NONE

SHEET No	C-4
	SHEET 8 OF 24

APPROVED

Date: November 17, 2012 - 2:33pm / User: devin.moore
 Path: K:\LV_Public\Trans\092061019 - Clark County Strip Ped Study\CADD\Plan Sheets\092061019_Russell to Trop Jan 09.dwg / Xref: X092061019_TB_X092061019_AE_2011_RusselltoTropicana;X092061019_topopdata.drawing;Encore_Offsites_Palazzo_entrances;X092061019_XCityCenter_MP-010;X092061019_Whitelines.dwg
 This document, together with the concepts and designs presented herein, is an instrument of service, to be used only for the specific purpose and client for which it was prepared. No part of this document, without written authorization and approval by Employment and Associates, Inc. shall be reproduced or transmitted in any form or by any means, electronic, mechanical, photocopying, recording, or by any information storage and retrieval system, without the prior written permission of Employment and Associates, Inc.

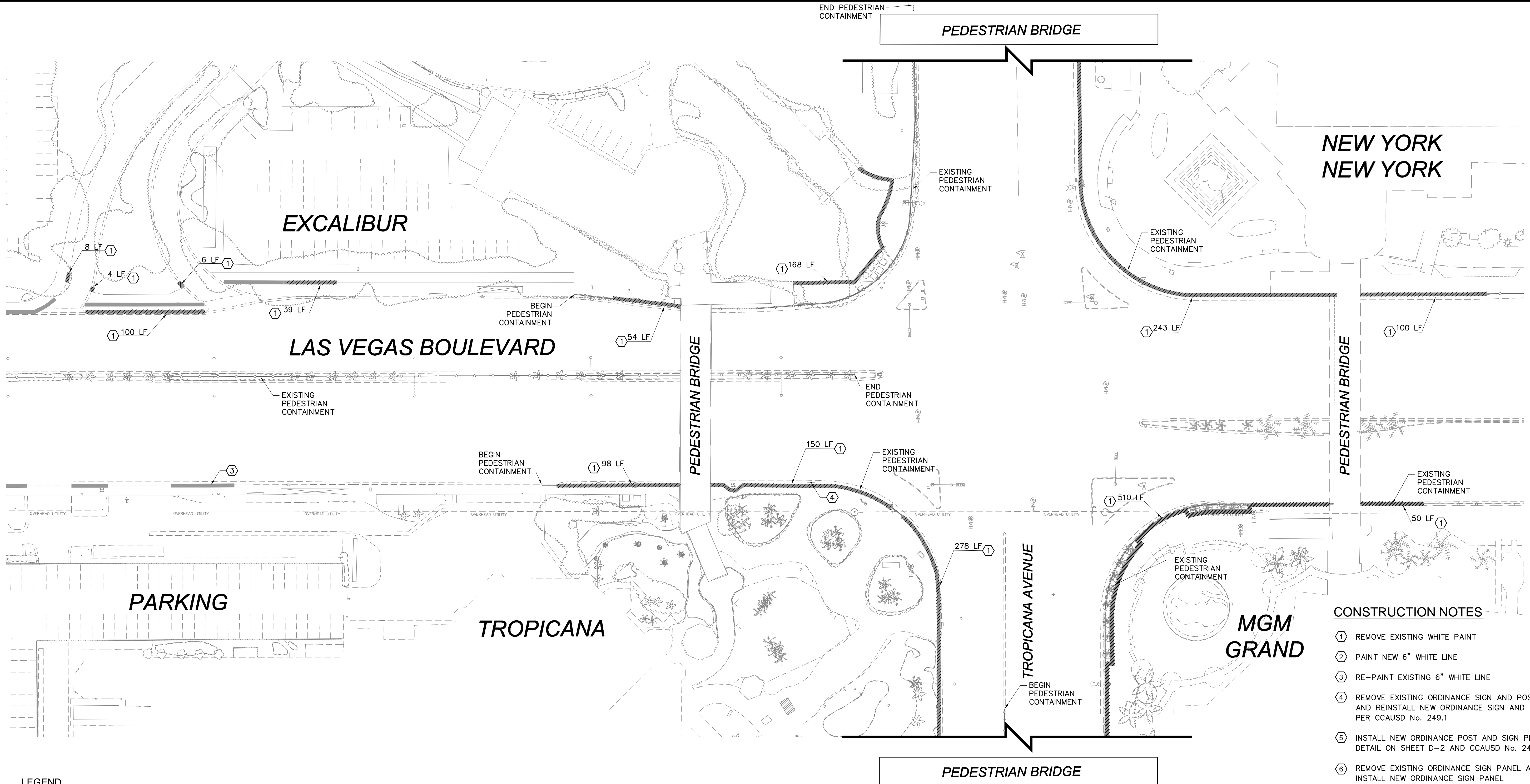

LEGEND

	EXISTING TOP OF CURB WHITE LINE
	INSTALL 6" TOP OF CURB WHITE LINE
	REMOVE EXISTING TOP OF CURB WHITE LINE
	INACTIVE DRIVEWAY

- CONSTRUCTION NOTES**
- ① REMOVE EXISTING WHITE PAINT
 - ② PAINT NEW 6" WHITE LINE
 - ③ RE-PAINT EXISTING 6" WHITE LINE
 - ④ REMOVE EXISTING ORDINANCE SIGN AND POST AND REINSTALL NEW ORDINANCE SIGN AND POST PER CCAUD No. 249.1
 - ⑤ INSTALL NEW ORDINANCE POST AND SIGN PER DETAIL ON SHEET D-2 AND CCAUD No. 249.1
 - ⑥ REMOVE EXISTING ORDINANCE SIGN PANEL AND INSTALL NEW ORDINANCE SIGN PANEL

NOTE: PROTECT EXISTING 6" WHITE LINE UNLESS NOTED OTHERWISE

NOTE: TOPOGRAPHIC INFORMATION SHOWN ON THESE PLANS WAS DEVELOPED BASED ON A SEARCH OF BEST AVAILABLE RECORDS AND INFORMATION. LOCATIONS AND CONDITION OF IMPROVEMENTS SHOWN ARE SUBJECT TO CHANGE AND SHALL BE VERIFIED IN THE FIELD.

BENCHMARK
NO SURVEY

BASIS OF BEARING
NO SURVEY

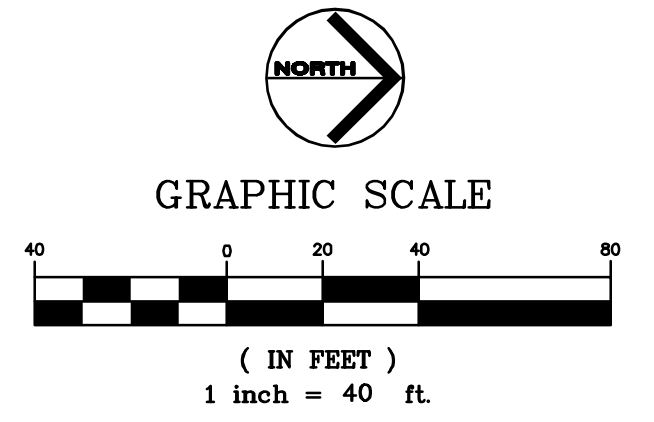

PEDESTRIAN STUDY - LAS VEGAS BLVD
 UPDATED NO OBSTRUCTIVE USE DRAWINGS
 RUSSELL ROAD TO SAHARA AVENUE
 CLARK COUNTY, NEVADA, DEPARTMENT OF PUBLIC WORKS

PRELIMINARY DRAWINGS
90%
 FOR REVIEW

DESIGNED BY:	SRA
DRAWN BY:	SAS
CHECKED BY:	KWA
DATE:	Nov 17, 2012 - 2:33pm

SCALE	
HORIZ:	AS SHOWN
VERT:	N/A
FIELD BOOK	NONE



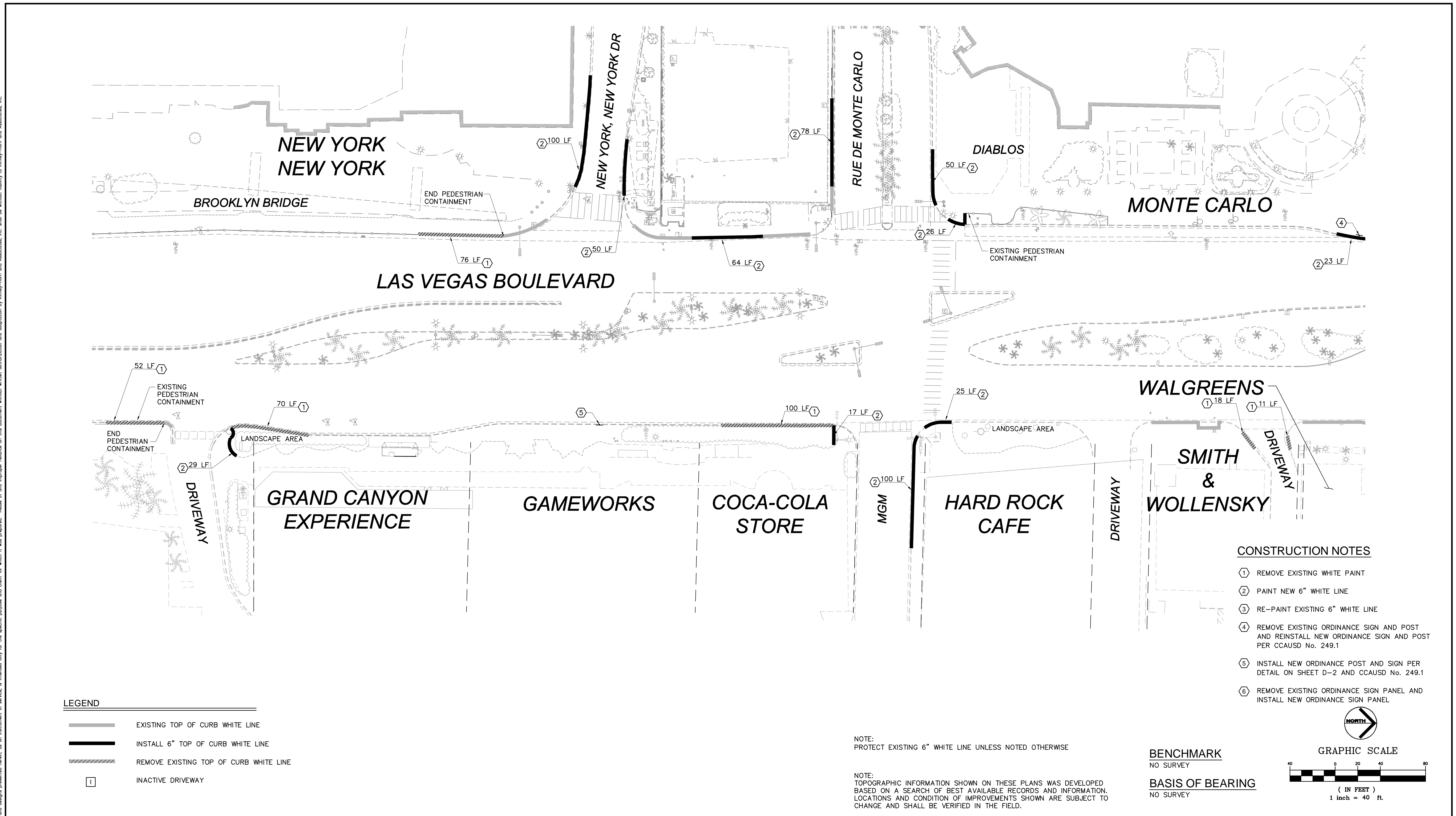

SHEET No	C-5
	SHEET 9 OF 24

APPROVED

Date: November 17, 2012 - 2:34pm / User: devin.moore
 Path: K:\AV_PublicTrans\092061019 - Clark County Strip Ped Study\CADD\Plan Sheets\092061019_AE_2011_Trop\092061019_Top to Flam Jan 09.dwg / Vref: X092061019_AE_2011_Trop\092061019_Top to Flam Jan 09.dwg / File: X092061019_AE_2011_Trop\092061019_Top to Flam Jan 09.dwg / Project: X092061019 - Clark County Strip Ped Study\CADD\Plan Sheets\092061019_AE_2011_Trop\092061019_Top to Flam Jan 09.dwg / Title: PEDESTRIAN STUDY - LAS VEGAS BLVD
 This document, together with the concepts and designs presented herein, is intended only for the specific purpose and client for which it was prepared. None of our employees or associates, in whole or in part, are responsible for any errors or omissions in this document, without written authorization and approval by our firm and its associated entities.



LEGEND

-  EXISTING TOP OF CURB WHITE LINE
-  INSTALL 6" TOP OF CURB WHITE LINE
-  REMOVE EXISTING TOP OF CURB WHITE LINE
-  INACTIVE DRIVEWAY

CONSTRUCTION NOTES

- ① REMOVE EXISTING WHITE PAINT
- ② PAINT NEW 6" WHITE LINE
- ③ RE-PAINT EXISTING 6" WHITE LINE
- ④ REMOVE EXISTING ORDINANCE SIGN AND POST AND REINSTALL NEW ORDINANCE SIGN AND POST PER CCAUSD No. 249.1
- ⑤ INSTALL NEW ORDINANCE POST AND SIGN PER DETAIL ON SHEET D-2 AND CCAUSD No. 249.1
- ⑥ REMOVE EXISTING ORDINANCE SIGN PANEL AND INSTALL NEW ORDINANCE SIGN PANEL

NOTE:
 PROTECT EXISTING 6" WHITE LINE UNLESS NOTED OTHERWISE

NOTE:
 TOPOGRAPHIC INFORMATION SHOWN ON THESE PLANS WAS DEVELOPED BASED ON A SEARCH OF BEST AVAILABLE RECORDS AND INFORMATION. LOCATIONS AND CONDITION OF IMPROVEMENTS SHOWN ARE SUBJECT TO CHANGE AND SHALL BE VERIFIED IN THE FIELD.

BENCHMARK
 NO SURVEY

BASIS OF BEARING
 NO SURVEY

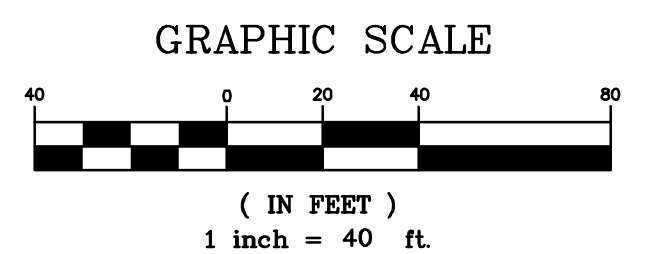

PEDESTRIAN STUDY - LAS VEGAS BLVD
 UPDATED NO OBSTRUCTIVE USE DRAWINGS
 RUSSELL ROAD TO SAHARA AVENUE
 CLARK COUNTY, NEVADA, DEPARTMENT OF PUBLIC WORKS

PRELIMINARY DRAWINGS

90%

FOR REVIEW

DESIGNED BY:	SRA
DRAWN BY:	SAS
CHECKED BY:	KWA
DATE:	Nov 17, 2012 - 2:34pm

SCALE	
HORIZ:	AS SHOWN
VERT:	N/A
FIELD BOOK	NONE

SHEET No	
C-6	
SHEET 10 OF 24	

APPROVED

Date: November 17, 2012 - 2:34pm / User: devin.moore
 Path: K:\LAJ_Public\Trans\092061019 - Clark County Strip Ped Study\CADD\Plan Sheets\092061019_AE_2011_TropicanFormings\092061019_Reinforcement Line\092061019_whatlineuse.dwg / Vref: X092061019_topupdate\092061019_topupdate.dwg / X092061019_SCityCenter_MP-010_X092061019
 This document, together with the concepts and designs presented herein, is intended only for the specific purpose and client for which it was prepared. Release of any information contained herein without written authorization and approval by Tropican Formings and Associates, Inc. shall be without liability to Tropican Formings and Associates, Inc.

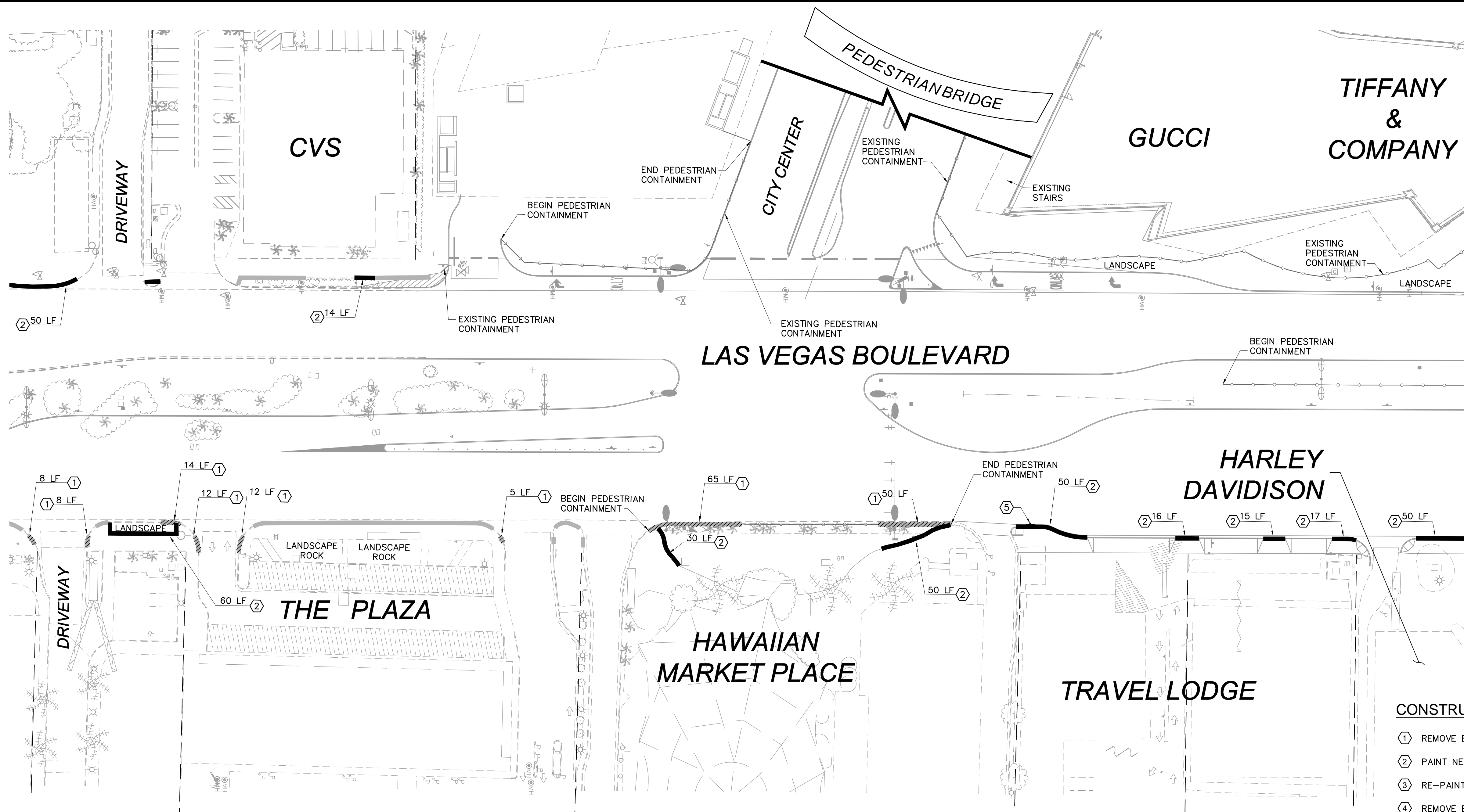

LEGEND

	EXISTING TOP OF CURB WHITE LINE
	INSTALL 6" TOP OF CURB WHITE LINE
	REMOVE EXISTING TOP OF CURB WHITE LINE
	INACTIVE DRIVEWAY

- CONSTRUCTION NOTES**
- ① REMOVE EXISTING WHITE PAINT
 - ② PAINT NEW 6" WHITE LINE
 - ③ RE-PAINT EXISTING 6" WHITE LINE
 - ④ REMOVE EXISTING ORDINANCE SIGN AND POST AND REINSTALL NEW ORDINANCE SIGN AND POST PER CCAUD No. 249.1
 - ⑤ INSTALL NEW ORDINANCE POST AND SIGN PER DETAIL ON SHEET D-2 AND CCAUD No. 249.1
 - ⑥ REMOVE EXISTING ORDINANCE SIGN PANEL AND INSTALL NEW ORDINANCE SIGN PANEL

NOTE:
PROTECT EXISTING 6" WHITE LINE UNLESS NOTED OTHERWISE

NOTE:
TOPOGRAPHIC INFORMATION SHOWN ON THESE PLANS WAS DEVELOPED BASED ON A SEARCH OF BEST AVAILABLE RECORDS AND INFORMATION. LOCATIONS AND CONDITION OF IMPROVEMENTS SHOWN ARE SUBJECT TO CHANGE AND SHALL BE VERIFIED IN THE FIELD.

BENCHMARK
NO SURVEY

BASIS OF BEARING
NO SURVEY

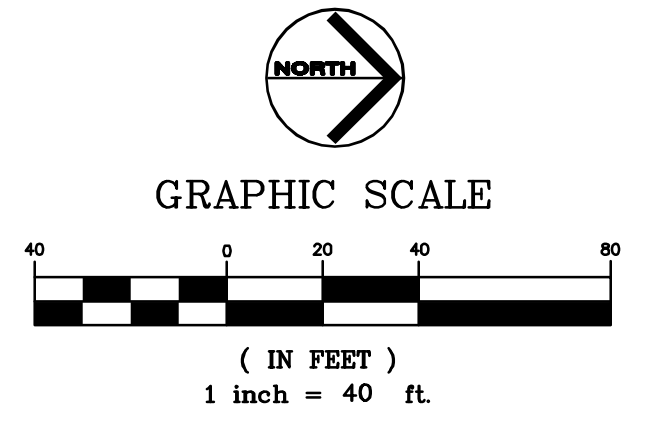

PEDESTRIAN STUDY - LAS VEGAS BLVD
 UPDATED NO OBSTRUCTIVE USE DRAWINGS
 RUSSELL ROAD TO SAHARA AVENUE
 CLARK COUNTY, NEVADA, DEPARTMENT OF PUBLIC WORKS

PRELIMINARY DRAWINGS
90%
 FOR REVIEW

DESIGNED BY: SRA
 DRAWN BY: SAS
 CHECKED BY: KWA
 DATE: Nov 17, 2012 - 2:34pm

SCALE
 HORIZ: AS SHOWN
 VERT: N/A
 FIELD BOOK: NONE

SHEET No
C-7
 SHEET 11 OF 24

APPROVED

Date: November 17, 2012 - 2:34pm / User: devin.moore
 Path: K:\LAJ_PublicTrans\092061019 - Clark County Strip Ped Study\CADD\Plan Sheets\092061019_Trop to Flam Jan 09.dwg / Vref: X092061019_AE_2011_TropianatFormings;X092061019_Reinforcement Line;X092061019_Whiteline;Polozzo entrance;X092061019_topupdate;X092061019_SCityCenter_MP-010;X092061019
 This document, together with the concepts and designs presented herein, is intended only for the specific purpose and client for which it was prepared. None of our employees or subcontractors shall be authorized to make any modification or adaptation by any person without written authorization and approval by the engineer and his/her firm.

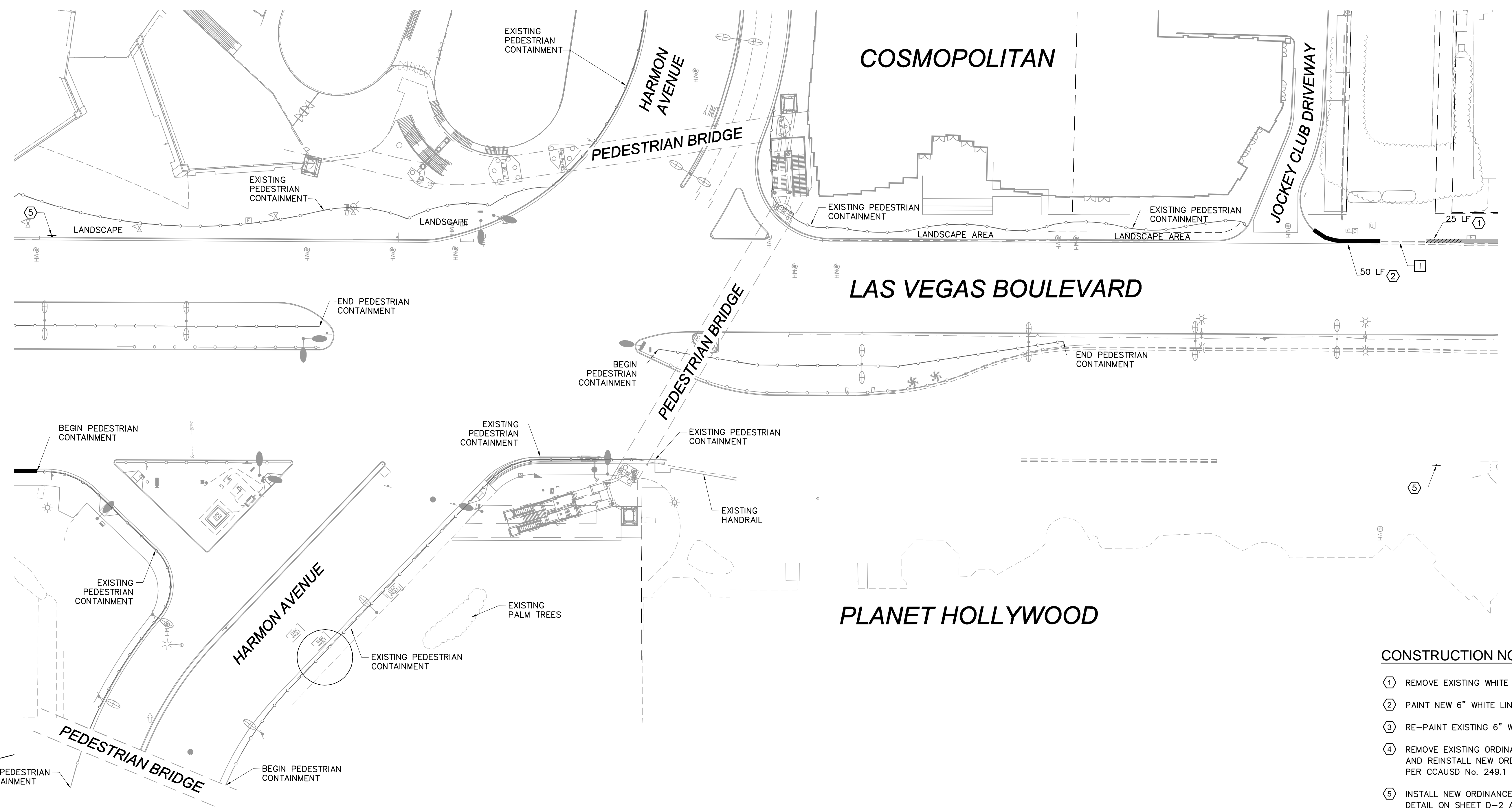

- CONSTRUCTION NOTES**
- ① REMOVE EXISTING WHITE PAINT
 - ② PAINT NEW 6" WHITE LINE
 - ③ RE-PAINT EXISTING 6" WHITE LINE
 - ④ REMOVE EXISTING ORDINANCE SIGN AND POST AND REINSTALL NEW ORDINANCE SIGN AND POST PER CCAUSD No. 249.1
 - ⑤ INSTALL NEW ORDINANCE POST AND SIGN PER DETAIL ON SHEET D-2 AND CCAUSD No. 249.1
 - ⑥ REMOVE EXISTING ORDINANCE SIGN PANEL AND INSTALL NEW ORDINANCE SIGN PANEL

LEGEND

	EXISTING TOP OF CURB WHITE LINE
	INSTALL 6" TOP OF CURB WHITE LINE
	REMOVE EXISTING TOP OF CURB WHITE LINE
	INACTIVE DRIVEWAY

NOTE:
PROTECT EXISTING 6" WHITE LINE UNLESS NOTED OTHERWISE

NOTE:
TOPOGRAPHIC INFORMATION SHOWN ON THESE PLANS WAS DEVELOPED BASED ON A SEARCH OF BEST AVAILABLE RECORDS AND INFORMATION. LOCATIONS AND CONDITION OF IMPROVEMENTS SHOWN ARE SUBJECT TO CHANGE AND SHALL BE VERIFIED IN THE FIELD.

BENCHMARK
NO SURVEY

BASIS OF BEARING
NO SURVEY

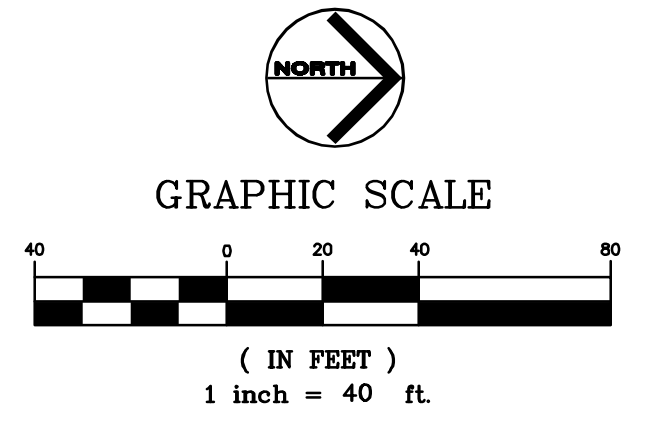

PEDESTRIAN STUDY - LAS VEGAS BLVD
 UPDATED NO OBSTRUCTIVE USE DRAWINGS
 RUSSELL ROAD TO SAHARA AVENUE
 CLARK COUNTY, NEVADA, DEPARTMENT OF PUBLIC WORKS

PRELIMINARY DRAWINGS
90%
FOR REVIEW

DESIGNED BY: SRA
 DRAWN BY: SAS
 CHECKED BY: KWA
 DATE: Nov 17, 2012 - 2:34pm

SCALE
 HORIZ: AS SHOWN
 VERT: N/A
 FIELD BOOK NONE



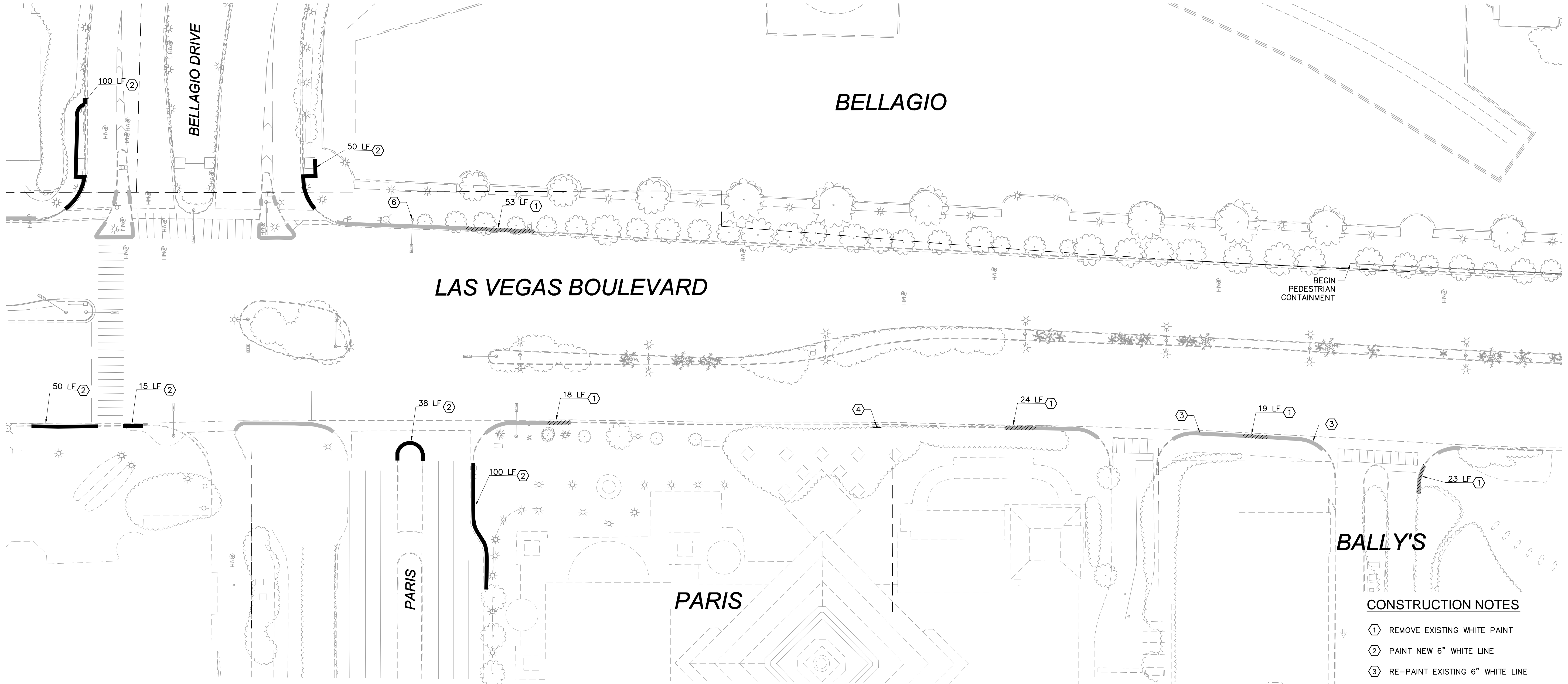

SHEET No
C-8
SHEET 12 OF 24

APPROVED

Date: November 17, 2012 - 2:35pm / User: devin.moore
 Path: K:\AV_PublicTrans\092061019 - Clark County Strip Ped Study\CADD\Plan Sheets\092061019_AE_2011_TropicanaFormings\092061019_Reinforcement Line\092061019_topupdate\092061019_SCHCenter_MP-010_X092061019.dwg / View: X092061019_AE_2011_TropicanaFormings\092061019_Reinforcement Line\092061019_topupdate\092061019_SCHCenter_MP-010_X092061019.dwg
 This document, together with the concepts and designs presented herein, is intended only for the specific purpose and client for which it was prepared. No other use or reproduction is permitted without the prior written consent and approval of the engineer and architect.



LEGEND

	EXISTING TOP OF CURB WHITE LINE
	INSTALL 6" TOP OF CURB WHITE LINE
	REMOVE EXISTING TOP OF CURB WHITE LINE
	INACTIVE DRIVEWAY

NOTE:
PROTECT EXISTING 6" WHITE LINE UNLESS NOTED OTHERWISE

NOTE:
TOPOGRAPHIC INFORMATION SHOWN ON THESE PLANS WAS DEVELOPED BASED ON A SEARCH OF BEST AVAILABLE RECORDS AND INFORMATION. LOCATIONS AND CONDITION OF IMPROVEMENTS SHOWN ARE SUBJECT TO CHANGE AND SHALL BE VERIFIED IN THE FIELD.

- CONSTRUCTION NOTES**
- ① REMOVE EXISTING WHITE PAINT
 - ② PAINT NEW 6" WHITE LINE
 - ③ RE-PAINT EXISTING 6" WHITE LINE
 - ④ REMOVE EXISTING ORDINANCE SIGN AND POST AND REINSTALL NEW ORDINANCE SIGN AND POST PER CCAUD No. 249.1
 - ⑤ INSTALL NEW ORDINANCE POST AND SIGN PER DETAIL ON SHEET D-2 AND CCAUD No. 249.1
 - ⑥ REMOVE EXISTING ORDINANCE SIGN PANEL AND INSTALL NEW ORDINANCE SIGN PANEL

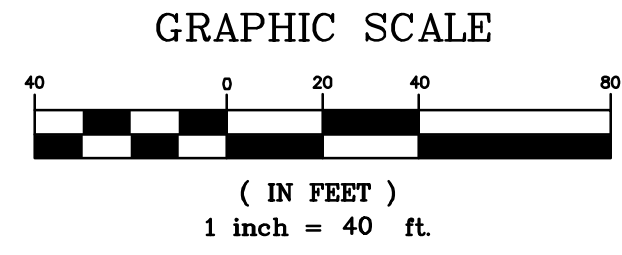

BENCHMARK
NO SURVEY

BASIS OF BEARING
NO SURVEY

APPROVED	
----------	---

PEDESTRIAN STUDY - LAS VEGAS BLVD
 UPDATED NO OBSTRUCTIVE USE DRAWINGS
 RUSSELL ROAD TO SAHARA AVENUE
 CLARK COUNTY, NEVADA, DEPARTMENT OF PUBLIC WORKS

PRELIMINARY DRAWINGS
90%
FOR REVIEW

DESIGNED BY:	SRA
DRAWN BY:	SAS
CHECKED BY:	KWA
DATE:	Nov 17, 2012 - 2:35pm

SCALE	HORIZ: AS SHOWN
	VERT: N/A
FIELD BOOK	NONE

SHEET No	C-9
	SHEET 13 OF 24

Date: November 17, 2012 - 2:35pm / User: devin.moore
 Path: K:\LVJ_PublicTrans\092061019 - Clark County Strip Ped Study\CADD\Plan Sheets\092061019_AE_2011_TripicantFlamingo\092061019_AE_2011_TripicantFlamingo.dwg / View: X092061019_AE_2011_TripicantFlamingo
 File: X092061019_AE_2011_TripicantFlamingo.dwg / Plot: Jan 09 09:49:42 AM 2012 / Plot Device: HP DesignJet T1100e
 This document, together with the concepts and designs presented herein, is intended only for the specific purpose and client for which it was prepared. No other use or reproduction is permitted without the prior written consent of the engineer and architect.

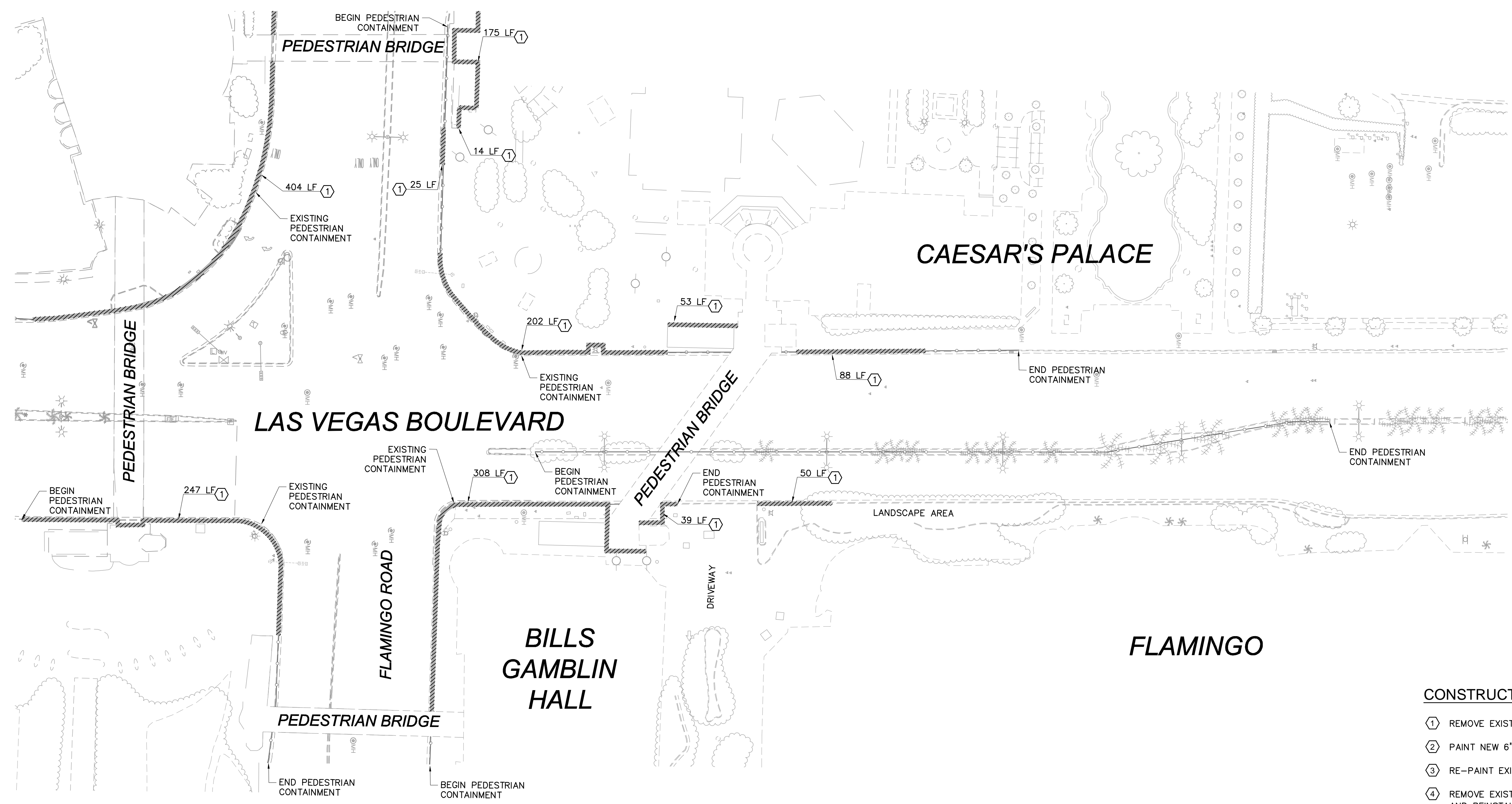

LEGEND	
	EXISTING TOP OF CURB WHITE LINE
	INSTALL 6" TOP OF CURB WHITE LINE
	REMOVE EXISTING TOP OF CURB WHITE LINE
	INACTIVE DRIVEWAY

- CONSTRUCTION NOTES**
- ① REMOVE EXISTING WHITE PAINT
 - ② PAINT NEW 6" WHITE LINE
 - ③ RE-PAINT EXISTING 6" WHITE LINE
 - ④ REMOVE EXISTING ORDINANCE SIGN AND POST AND REINSTALL NEW ORDINANCE SIGN AND POST PER CCAUD No. 249.1
 - ⑤ INSTALL NEW ORDINANCE POST AND SIGN PER DETAIL ON SHEET D-2 AND CCAUD No. 249.1
 - ⑥ REMOVE EXISTING ORDINANCE SIGN PANEL AND INSTALL NEW ORDINANCE SIGN PANEL

NOTE:
PROTECT EXISTING 6" WHITE LINE UNLESS NOTED OTHERWISE

NOTE:
TOPOGRAPHIC INFORMATION SHOWN ON THESE PLANS WAS DEVELOPED BASED ON A SEARCH OF BEST AVAILABLE RECORDS AND INFORMATION. LOCATIONS AND CONDITION OF IMPROVEMENTS SHOWN ARE SUBJECT TO CHANGE AND SHALL BE VERIFIED IN THE FIELD.

BENCHMARK
NO SURVEY

BASIS OF BEARING
NO SURVEY

GRAPHIC SCALE
(IN FEET)
1 inch = 40 ft.

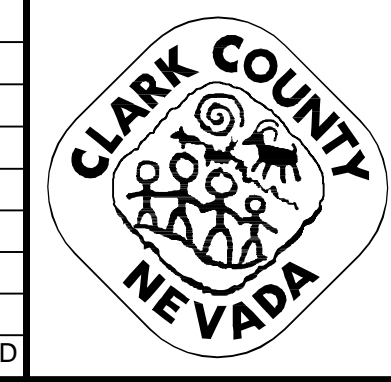

PEDESTRIAN STUDY - LAS VEGAS BLVD
 UPDATED NO OBSTRUCTIVE USE DRAWINGS
 RUSSELL ROAD TO SAHARA AVENUE
 CLARK COUNTY, NEVADA, DEPARTMENT OF PUBLIC WORKS

PRELIMINARY DRAWINGS
90%
FOR REVIEW

DESIGNED BY:	SRA
DRAWN BY:	SAS
CHECKED BY:	KWA
DATE:	Nov 17, 2012 - 2:35pm

SCALE	HORIZ: AS SHOWN	SHEET No C-10
	VERT: N/A	
	FIELD BOOK NONE	SHEET 14 OF 24

APPROVED

Date: November 17, 2012 - 2:36pm / User: devin.moore
 Path: K:\LV_Public\Trans\092061019 - Clark County Strip Ped Study\CADD\Plan Sheets\092061019_AE_2011_Firming.rvt
 Plan: 092061019_AE_2011_Firming.rvt
 Title: PEDESTRIAN STUDY - LAS VEGAS BLVD
 Project: CLARK COUNTY STRIP PEDESTRIAN STUDY
 Drawing: PEDESTRIAN STUDY - LAS VEGAS BLVD
 Scale: AS SHOWN
 Date: Nov 17, 2012 - 2:36pm
 Designer: SRA
 Drafter: SAS
 Checker: KWA
 Date: Nov 17, 2012 - 2:36pm

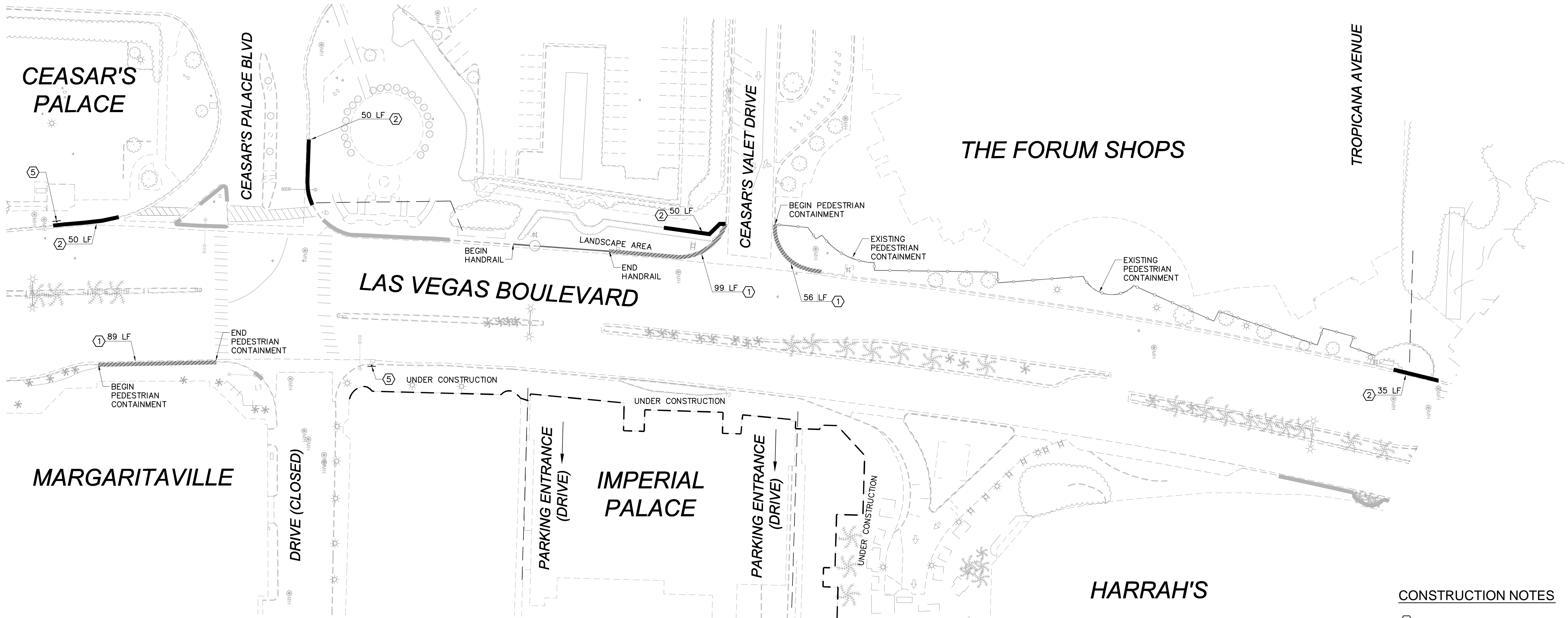

LEGEND

	EXISTING TOP OF CURB WHITE LINE
	INSTALL 6" TOP OF CURB WHITE LINE
	REMOVE EXISTING TOP OF CURB WHITE LINE
	INACTIVE DRIVEWAY

NOTE:
 PROTECT EXISTING 6" WHITE LINE UNLESS NOTED OTHERWISE

NOTE:
 TOPOGRAPHIC INFORMATION SHOWN ON THESE PLANS WAS DEVELOPED
 BASED ON A SEARCH OF BEST AVAILABLE RECORDS AND INFORMATION.
 LOCATIONS AND CONDITION OF IMPROVEMENTS SHOWN ARE SUBJECT TO
 CHANGE AND SHALL BE VERIFIED IN THE FIELD.

- CONSTRUCTION NOTES**
- ① REMOVE EXISTING WHITE PAINT
 - ② PAINT NEW 6" WHITE LINE
 - ③ RE-PAINT EXISTING 6" WHITE LINE
 - ④ REMOVE EXISTING ORDINANCE SIGN AND POST AND REINSTALL NEW ORDINANCE SIGN AND POST PER CCAUSD No. 249.1
 - ⑤ INSTALL NEW ORDINANCE POST AND SIGN PER DETAIL ON SHEET D-2 AND CCAUSD No. 249.1
 - ⑥ REMOVE EXISTING ORDINANCE SIGN PANEL AND INSTALL NEW ORDINANCE SIGN PANEL

BENCHMARK
 NO SURVEY

BASIS OF BEARING
 NO SURVEY

GRAPHIC SCALE
 (IN FEET)
 1 inch = 40 ft.



PEDESTRIAN STUDY - LAS VEGAS BLVD
 UPDATED NO OBSTRUCTIVE USE DRAWINGS
 RUSSELL ROAD TO SAHARA AVENUE
 CLARK COUNTY, NEVADA, DEPARTMENT OF PUBLIC WORKS

PRELIMINARY DRAWINGS
90%
 FOR REVIEW

DESIGNED BY:	SRA
DRAWN BY:	SAS
CHECKED BY:	KWA
DATE:	Nov 17, 2012 - 2:36pm

SCALE	HORIZ: AS SHOWN
	VERT: N/A
FIELD BOOK	NONE

SHEET No
C-11
 SHEET 15 OF 24

APPROVED

Date: November 17, 2012 - 2:36pm / User: devin.moore
 Path: K:\LAV_Public\Trans\092061019 - Clark County Strip Ped Study\CADD\Plan Sheets\092061019_Plan to DI Jan 09.dwg / Ref: X092061019_Revision\Line: X092061019_Palazzo entrance; X092061019_Topography; X092061019_WhiteLine; X092061019_TB; Encore Offices
 This document, together with the concepts and designs presented herein, is intended only for the specific purpose and client for which it was prepared. Plans of any other nature without written authorization and approval by Employment and Associates, Inc. shall be void. Liability to Employment and Associates, Inc.

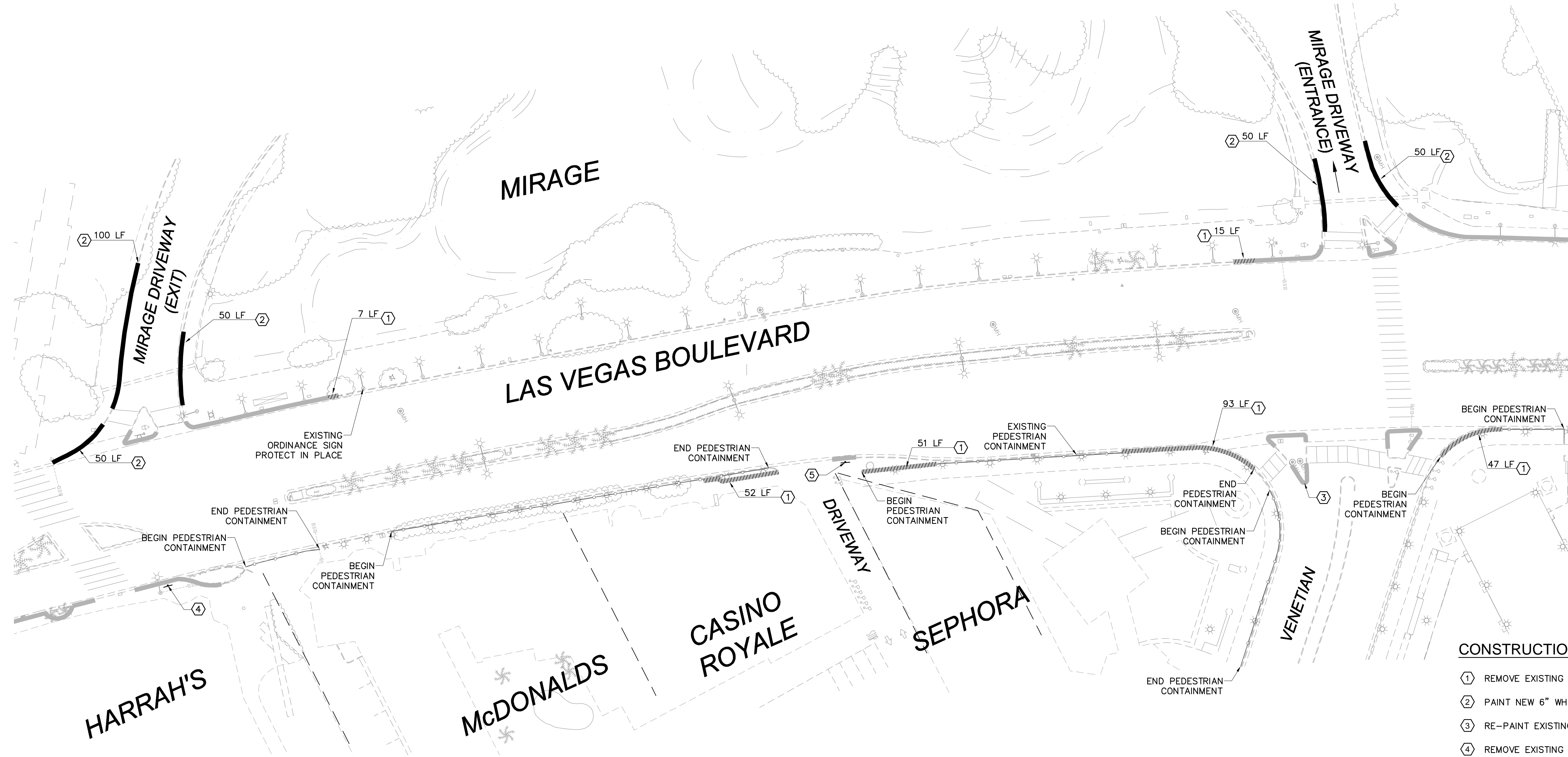

- CONSTRUCTION NOTES**
- ① REMOVE EXISTING WHITE PAINT
 - ② PAINT NEW 6" WHITE LINE
 - ③ RE-PAINT EXISTING 6" WHITE LINE
 - ④ REMOVE EXISTING ORDINANCE SIGN AND POST AND REINSTALL NEW ORDINANCE SIGN AND POST PER CCAUD No. 249.1
 - ⑤ INSTALL NEW ORDINANCE POST AND SIGN PER DETAIL ON SHEET D-2 AND CCAUD No. 249.1
 - ⑥ REMOVE EXISTING ORDINANCE SIGN PANEL AND INSTALL NEW ORDINANCE SIGN PANEL

LEGEND

	EXISTING TOP OF CURB WHITE LINE
	INSTALL 6" TOP OF CURB WHITE LINE
	REMOVE EXISTING TOP OF CURB WHITE LINE
	INACTIVE DRIVEWAY

NOTE:
PROTECT EXISTING 6" WHITE LINE UNLESS NOTED OTHERWISE

NOTE:
TOPOGRAPHIC INFORMATION SHOWN ON THESE PLANS WAS DEVELOPED BASED ON A SEARCH OF BEST AVAILABLE RECORDS AND INFORMATION. LOCATIONS AND CONDITION OF IMPROVEMENTS SHOWN ARE SUBJECT TO CHANGE AND SHALL BE VERIFIED IN THE FIELD.

BENCHMARK
NO SURVEY

BASIS OF BEARING
NO SURVEY

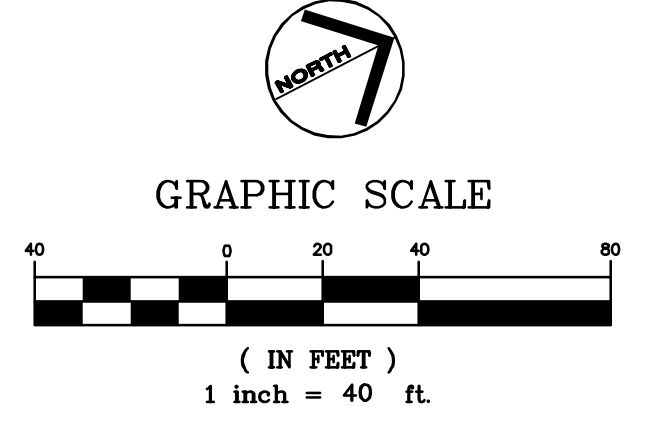



PEDESTRIAN STUDY - LAS VEGAS BLVD

UPDATED NO OBSTRUCTIVE USE DRAWINGS
 RUSSELL ROAD TO SAHARA AVENUE
 CLARK COUNTY, NEVADA, DEPARTMENT OF PUBLIC WORKS

PRELIMINARY DRAWINGS

90%

FOR REVIEW

DESIGNED BY:	SRA
DRAWN BY:	SAS
CHECKED BY:	KWA
DATE:	Nov 17, 2012 - 2:36pm

SCALE	
HORIZ:	AS SHOWN
VERT:	N/A
FIELD BOOK	NONE

SHEET No
C-12
SHEET 16 OF 24

Date: November 17, 2012 - 2:36pm / User: devin.moore
 Path: K:\LAV_PublicTrans\092061019 - Clark County Strip Ped Study\CADD\Plan Sheets\092061019_Plan_Sheets\092061019_AE_2011_Framing.cad / Plot: X092061019_Plan_Sheets\092061019_AE_2011_Framing.ctb / Palazzo entrance: X092061019_Topuplot.ctb; X092061019_WhiteLine.ctb; X092061019_TB; Encore Offices
 This document, together with the concepts and designs presented herein, is intended only for the specific purpose and client for which it was prepared. Release of any information contained herein without written authorization and approval by Transportation and Associates, Inc. shall be without liability to Transportation and Associates, Inc.

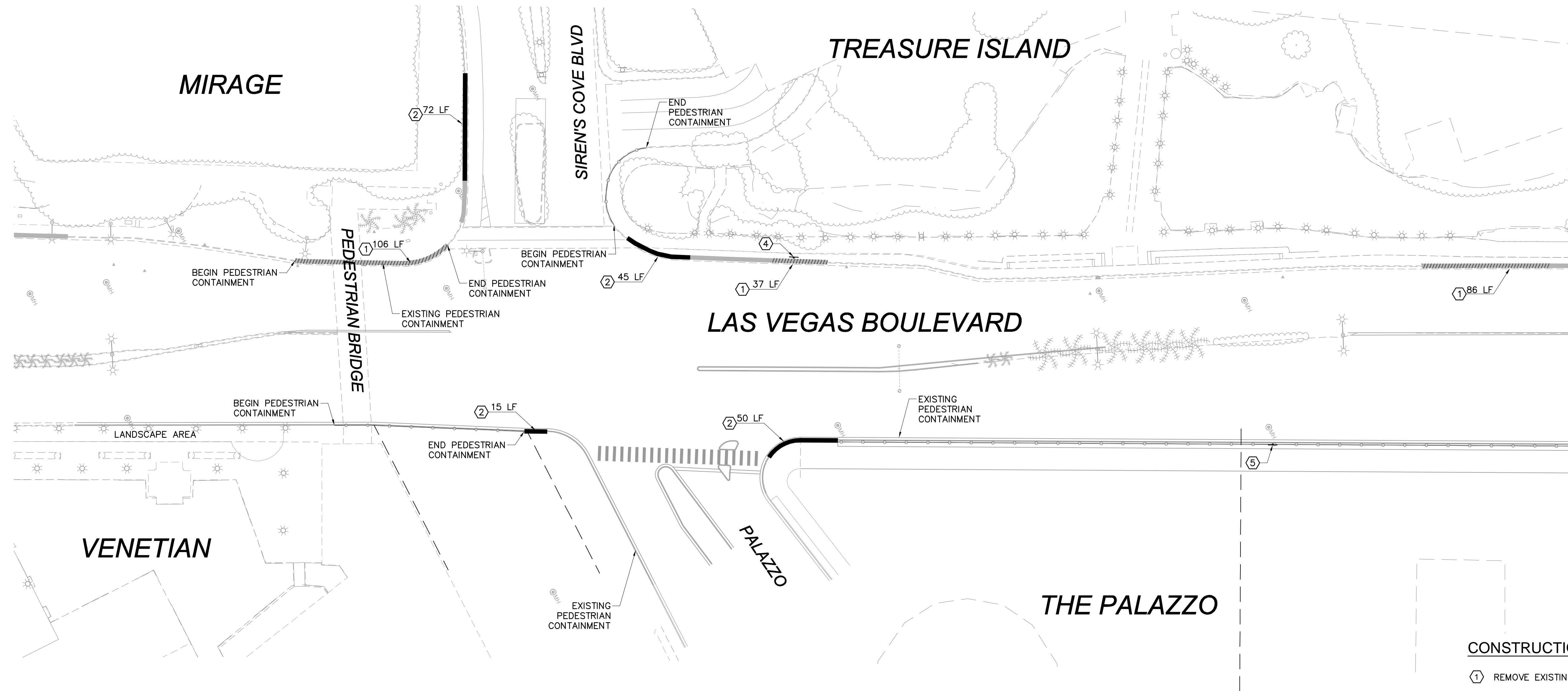

LEGEND

	EXISTING TOP OF CURB WHITE LINE
	INSTALL 6" TOP OF CURB WHITE LINE
	REMOVE EXISTING TOP OF CURB WHITE LINE
	INACTIVE DRIVEWAY

- CONSTRUCTION NOTES**
- ① REMOVE EXISTING WHITE PAINT
 - ② PAINT NEW 6" WHITE LINE
 - ③ RE-PAINT EXISTING 6" WHITE LINE
 - ④ REMOVE EXISTING ORDINANCE SIGN AND POST AND REINSTALL NEW ORDINANCE SIGN AND POST PER CCAUSD No. 249.1
 - ⑤ INSTALL NEW ORDINANCE POST AND SIGN PER DETAIL ON SHEET D-2 AND CCAUSD No. 249.1
 - ⑥ REMOVE EXISTING ORDINANCE SIGN PANEL AND INSTALL NEW ORDINANCE SIGN PANEL

NOTE:
PROTECT EXISTING 6" WHITE LINE UNLESS NOTED OTHERWISE

NOTE:
TOPOGRAPHIC INFORMATION SHOWN ON THESE PLANS WAS DEVELOPED BASED ON A SEARCH OF BEST AVAILABLE RECORDS AND INFORMATION. LOCATIONS AND CONDITION OF IMPROVEMENTS SHOWN ARE SUBJECT TO CHANGE AND SHALL BE VERIFIED IN THE FIELD.

BENCHMARK
NO SURVEY

BASIS OF BEARING
NO SURVEY

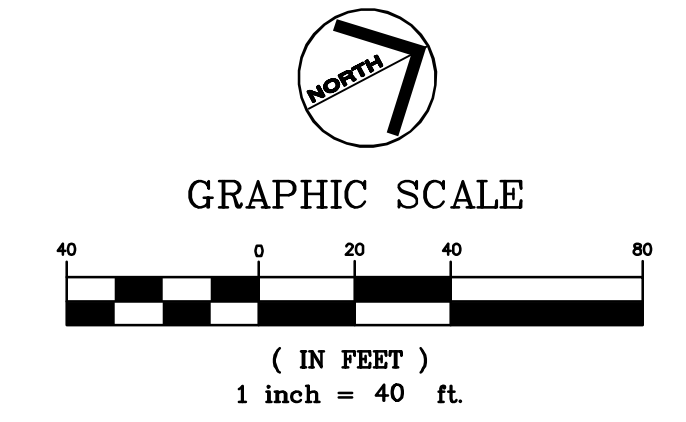

APPROVED



PEDESTRIAN STUDY - LAS VEGAS BLVD
 UPDATED NO OBSTRUCTIVE USE DRAWINGS
 RUSSELL ROAD TO SAHARA AVENUE
 CLARK COUNTY, NEVADA, DEPARTMENT OF PUBLIC WORKS

PRELIMINARY DRAWINGS

90%
FOR REVIEW

DESIGNED BY: SRA
 DRAWN BY: SAS
 CHECKED BY: KWA
 DATE: Nov 17, 2012 - 2:36pm

SCALE

HORIZ: AS SHOWN

VERT: N/A

FIELD BOOK NONE

SHEET No

C-13

SHEET 17 OF 24

Date: November 17, 2012 - 2:36pm / User: devinmoore
 Path: X:\LA_Publications\092061019_Plan_Sheet\092061019_Plan_Sheet.dwg / Xref: X:\092061019_Refer\092061019_Refer.dwg
 Plot: 092061019_Plan_Sheet.dwg
 Title: PEDESTRIAN STUDY - LAS VEGAS BLVD
 Author: devinmoore
 Date: 11/17/2012
 Time: 2:36:00 PM
 Plot Device: HP DesignJet T1100e
 Plot Style: HP-GL/2
 Scale: 1:1
 Sheet: 18 of 24

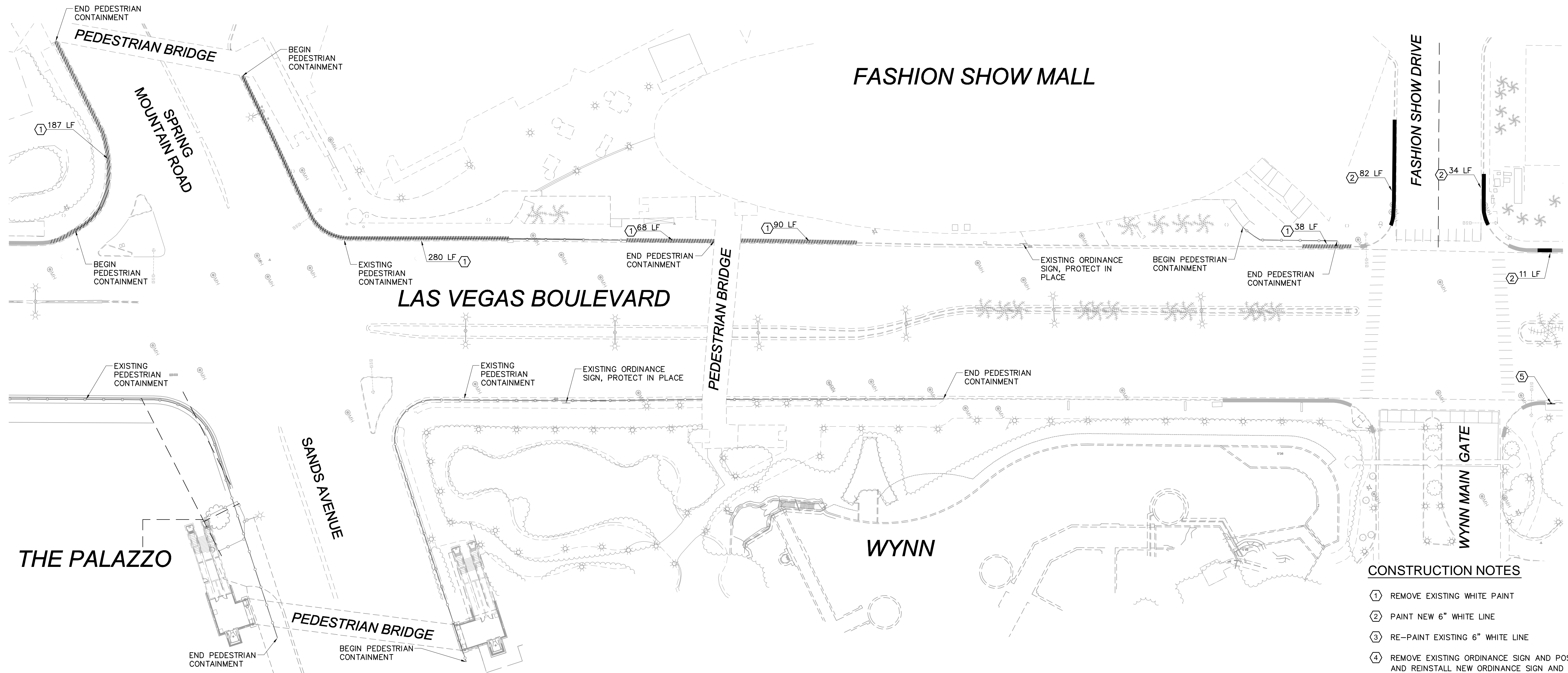

LEGEND

	EXISTING TOP OF CURB WHITE LINE
	INSTALL 6" TOP OF CURB WHITE LINE
	REMOVE EXISTING TOP OF CURB WHITE LINE
	INACTIVE DRIVEWAY

- CONSTRUCTION NOTES**
- ① REMOVE EXISTING WHITE PAINT
 - ② PAINT NEW 6" WHITE LINE
 - ③ RE-PAINT EXISTING 6" WHITE LINE
 - ④ REMOVE EXISTING ORDINANCE SIGN AND POST AND REINSTALL NEW ORDINANCE SIGN AND POST PER CCAUSD No. 249.1
 - ⑤ INSTALL NEW ORDINANCE POST AND SIGN PER DETAIL ON SHEET D-2 AND CCAUSD No. 249.1
 - ⑥ REMOVE EXISTING ORDINANCE SIGN PANEL AND INSTALL NEW ORDINANCE SIGN PANEL

NOTE:
PROTECT EXISTING 6" WHITE LINE UNLESS NOTED OTHERWISE

NOTE:
TOPOGRAPHIC INFORMATION SHOWN ON THESE PLANS WAS DEVELOPED BASED ON A SEARCH OF BEST AVAILABLE RECORDS AND INFORMATION. LOCATIONS AND CONDITION OF IMPROVEMENTS SHOWN ARE SUBJECT TO CHANGE AND SHALL BE VERIFIED IN THE FIELD.

BENCHMARK
NO SURVEY
BASIS OF BEARING
NO SURVEY

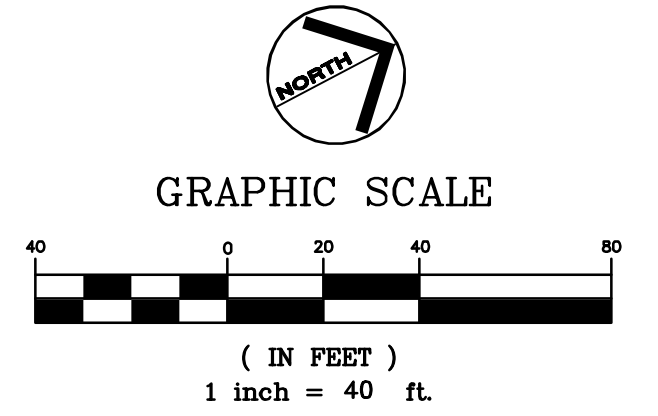

PEDESTRIAN STUDY - LAS VEGAS BLVD

UPDATED NO OBSTRUCTIVE USE DRAWINGS
 RUSSELL ROAD TO SAHARA AVENUE
 CLARK COUNTY, NEVADA, DEPARTMENT OF PUBLIC WORKS

PRELIMINARY DRAWINGS
90%
FOR REVIEW

DESIGNED BY:	SRA
DRAWN BY:	SAS
CHECKED BY:	KWA
DATE:	Nov 17, 2012 - 2:36pm

SCALE	HORIZ: AS SHOWN
	VERT: N/A
FIELD BOOK	NONE

SHEET No	C-14
	SHEET 18 OF 24

APPROVED

Date: November 17, 2012 - 2:37pm / User: devin.moore
 Path: K:\LV_Public\Trans\092061019 - Clark County Strip Ped Study\CADD\Plan Sheets\092061019_Plan to DI Jan 09.dwg / Ref: X092061019_Beliquishment_Line; X092061019_AE_2011_Firming; X092061019_Topupdotdet; X092061019_WhiteLineNew; X092061019_TB; Encore Offices
 This document, together with the concepts and designs presented herein, is intended only for the specific purpose and client for which it was prepared. Please do not disseminate or adapt this document without written authorization and approval by Employment and Associates, Inc. and be held liable to Employment and Associates, Inc.

UNDER CONSTRUCTION

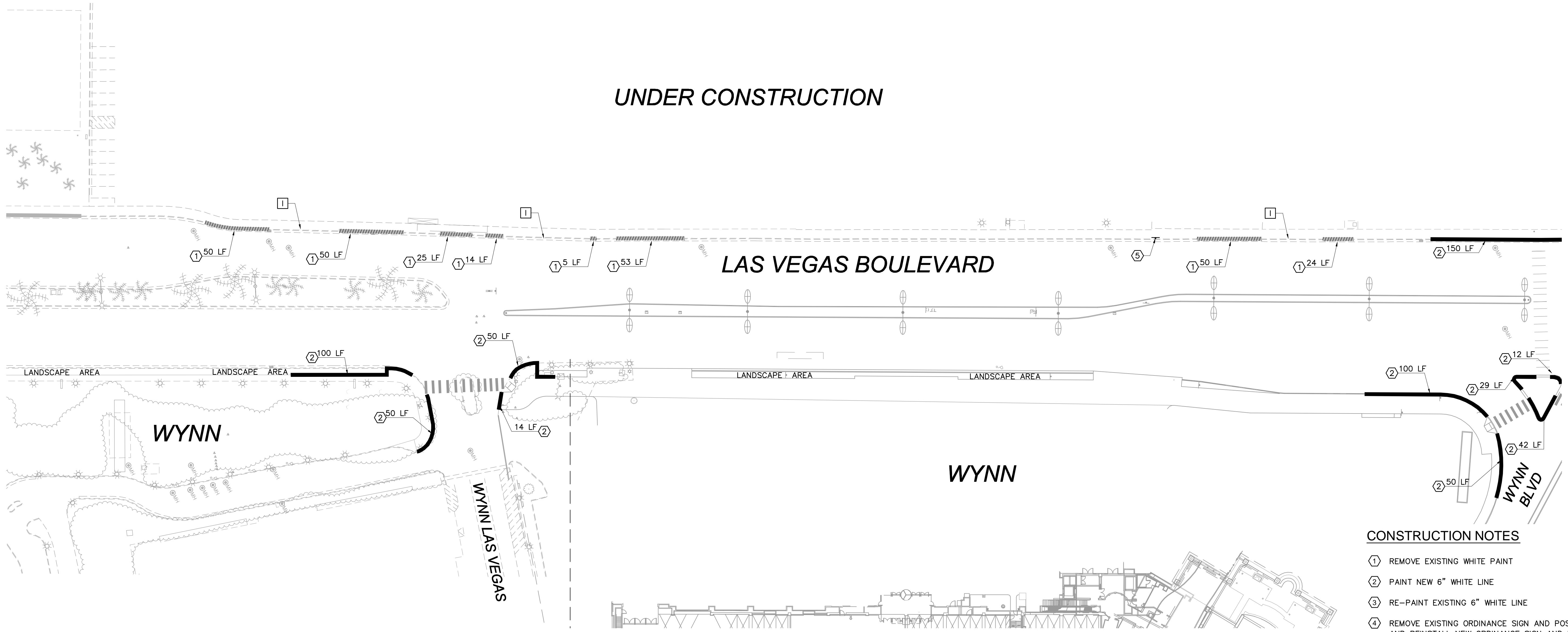

LEGEND

	EXISTING TOP OF CURB WHITE LINE
	INSTALL 6" TOP OF CURB WHITE LINE
	REMOVE EXISTING TOP OF CURB WHITE LINE
	INACTIVE DRIVEWAY

- CONSTRUCTION NOTES**
- ① REMOVE EXISTING WHITE PAINT
 - ② PAINT NEW 6" WHITE LINE
 - ③ RE-PAINT EXISTING 6" WHITE LINE
 - ④ REMOVE EXISTING ORDINANCE SIGN AND POST AND REINSTALL NEW ORDINANCE SIGN AND POST PER CCAUSD No. 249.1
 - ⑤ INSTALL NEW ORDINANCE POST AND SIGN PER DETAIL ON SHEET D-2 AND CCAUSD No. 249.1
 - ⑥ REMOVE EXISTING ORDINANCE SIGN PANEL AND INSTALL NEW ORDINANCE SIGN PANEL

NOTE:
PROTECT EXISTING 6" WHITE LINE UNLESS NOTED OTHERWISE

NOTE:
TOPOGRAPHIC INFORMATION SHOWN ON THESE PLANS WAS DEVELOPED BASED ON A SEARCH OF BEST AVAILABLE RECORDS AND INFORMATION. LOCATIONS AND CONDITION OF IMPROVEMENTS SHOWN ARE SUBJECT TO CHANGE AND SHALL BE VERIFIED IN THE FIELD.

BENCHMARK
NO SURVEY

BASIS OF BEARING
NO SURVEY

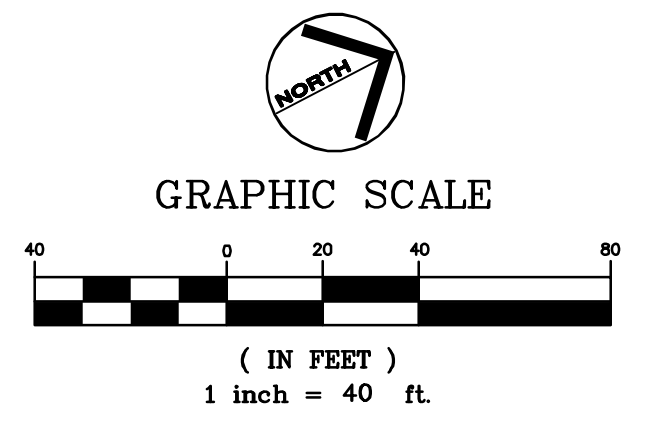



PEDESTRIAN STUDY - LAS VEGAS BLVD
 UPDATED NO OBSTRUCTIVE USE DRAWINGS
 RUSSELL ROAD TO SAHARA AVENUE
 CLARK COUNTY, NEVADA, DEPARTMENT OF PUBLIC WORKS

PRELIMINARY DRAWINGS
90%
 FOR REVIEW

DESIGNED BY:	SRA
DRAWN BY:	SAS
CHECKED BY:	KWA
DATE:	Nov 17, 2012 - 2:37pm

SCALE	HORIZ: AS SHOWN
	VERT: N/A
FIELD BOOK	NONE

SHEET No
C-15
 SHEET 19 OF 24

Date: November 17, 2012 - 2:37pm / User: devin.moore
 Path: K:\LAV_PublicTrans\092061019 - Clark County Strip Ped Study\CADD\Plan Sheets\092061019_D1 to Sahara Jan 09.dwg / Xref: X092061019_Reinforcement Line; X092061019_AE_2011_D1toSahara; X092061019_TopofGrade; X092061019_WhiteLineNew; X092061019_TB; Encore Offsites; Palazzo entrance
 This document, together with the concepts and designs presented herein, is intended only for the specific purpose and client for which it was prepared. None of the information contained herein shall be construed as a contract or a warranty of any kind, and no liability shall be assumed by the engineer or architect for any consequences arising from the use of this information for any other purpose.

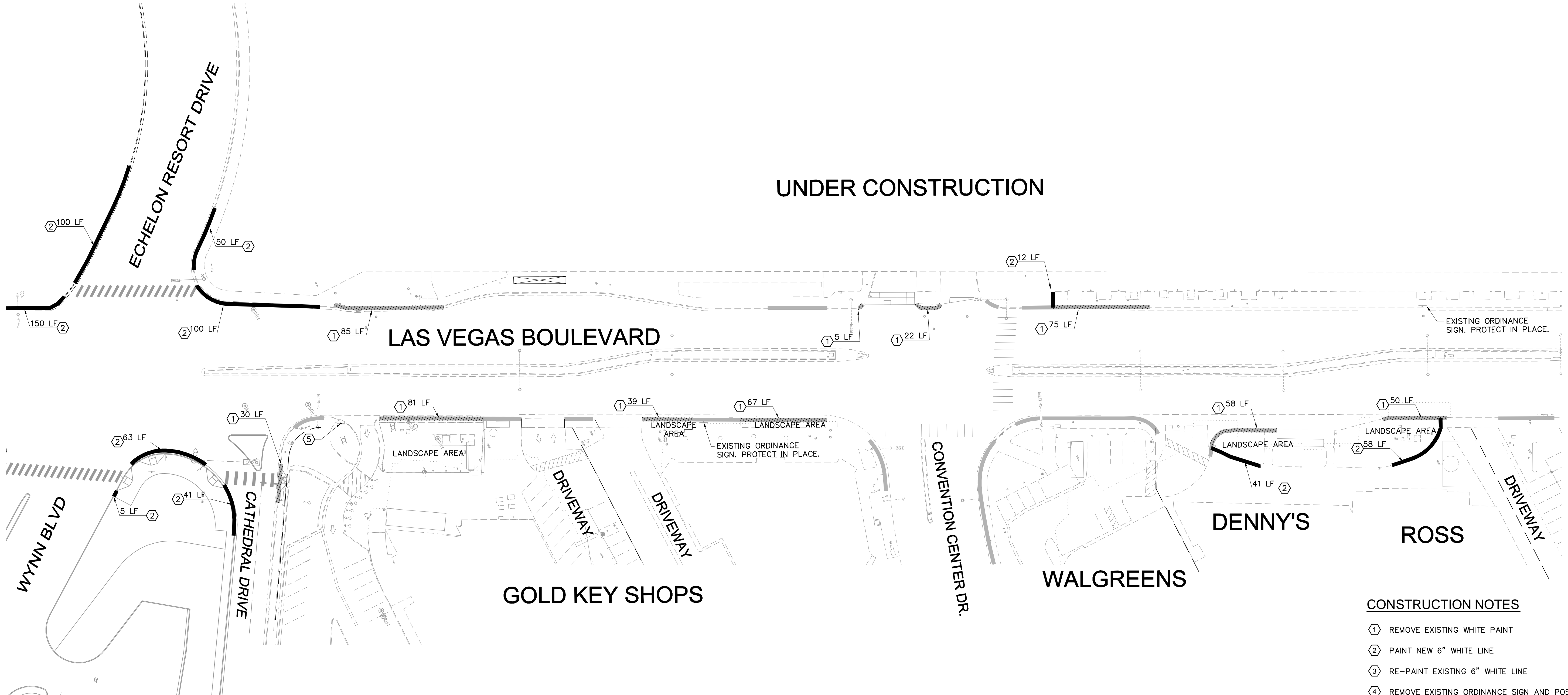

LEGEND

	EXISTING TOP OF CURB WHITE LINE
	INSTALL 6" TOP OF CURB WHITE LINE
	REMOVE EXISTING TOP OF CURB WHITE LINE
	INACTIVE DRIVEWAY

NOTE:
PROTECT EXISTING 6" WHITE LINE UNLESS NOTED OTHERWISE

NOTE:
TOPOGRAPHIC INFORMATION SHOWN ON THESE PLANS WAS DEVELOPED BASED ON A SEARCH OF BEST AVAILABLE RECORDS AND INFORMATION. LOCATIONS AND CONDITION OF IMPROVEMENTS SHOWN ARE SUBJECT TO CHANGE AND SHALL BE VERIFIED IN THE FIELD.

- CONSTRUCTION NOTES**
- ① REMOVE EXISTING WHITE PAINT
 - ② PAINT NEW 6" WHITE LINE
 - ③ RE-PAINT EXISTING 6" WHITE LINE
 - ④ REMOVE EXISTING ORDINANCE SIGN AND POST AND REINSTALL NEW ORDINANCE SIGN AND POST PER CCAUSD No. 249.1
 - ⑤ INSTALL NEW ORDINANCE POST AND SIGN PER DETAIL ON SHEET D-2 AND CCAUSD No. 249.1
 - ⑥ REMOVE EXISTING ORDINANCE SIGN PANEL AND INSTALL NEW ORDINANCE SIGN PANEL

BENCHMARK
NO SURVEY

BASIS OF BEARING
NO SURVEY

GRAPHIC SCALE

(IN FEET)
1 inch = 40 ft.

APPROVED	
----------	--



PEDESTRIAN STUDY - LAS VEGAS BLVD

UPDATED NO OBSTRUCTIVE USE DRAWINGS
RUSSELL ROAD TO SAHARA AVENUE
CLARK COUNTY, NEVADA, DEPARTMENT OF PUBLIC WORKS

PRELIMINARY DRAWINGS

90%

FOR REVIEW

DESIGNED BY:	SRA
DRAWN BY:	SAS
CHECKED BY:	KWA
DATE:	Nov 17, 2012 - 2:37pm

SCALE	
HORIZ:	AS SHOWN
VERT:	N/A
FIELD BOOK	NONE

SHEET No



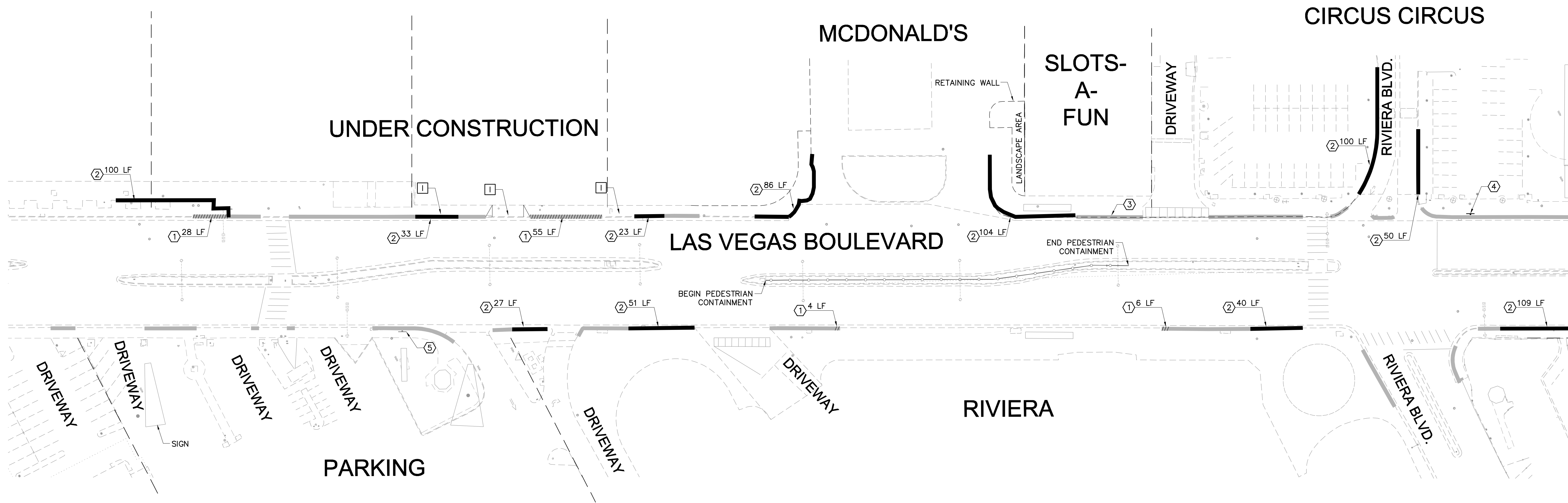

C-16

SHEET 20 OF 24

Date: November 17, 2012 - 2:38pm / User: devin.moore
 Path: K:\AJV_Public\Trans\092061019 - Clark County Strip Ped Study\CADD\Plan Sheets\092061019_Plan_Sheets\092061019_AE_2012\092061019_Topology.dwg / Xref: 092061019_Relinquishment_Line;092061019_WhiteLineNew;092061019_TB;Encore_Offices;Palazzo_entrance
 This document, together with the concepts and designs presented herein, is intended only for the specific purpose and client for which it was prepared. None of the information in this document shall be construed as a guarantee, warranty, or assurance of any kind by the engineer or architect, and shall be subject to change without notice. The engineer and architect accept no responsibility for any errors or omissions in this document, and shall be held harmless by the client and its representatives.



LEGEND

	EXISTING TOP OF CURB WHITE LINE
	INSTALL 6" TOP OF CURB WHITE LINE
	REMOVE EXISTING TOP OF CURB WHITE LINE
	INACTIVE DRIVEWAY

NOTE:
 PROTECT EXISTING 6" WHITE LINE UNLESS NOTED OTHERWISE

NOTE:
 TOPOGRAPHIC INFORMATION SHOWN ON THESE PLANS WAS DEVELOPED BASED ON A SEARCH OF BEST AVAILABLE RECORDS AND INFORMATION. LOCATIONS AND CONDITION OF IMPROVEMENTS SHOWN ARE SUBJECT TO CHANGE AND SHALL BE VERIFIED IN THE FIELD.

CONSTRUCTION NOTES

- ① REMOVE EXISTING WHITE PAINT
- ② PAINT NEW 6" WHITE LINE
- ③ RE-PAINT EXISTING 6" WHITE LINE
- ④ REMOVE EXISTING ORDINANCE SIGN AND POST AND REINSTALL NEW ORDINANCE SIGN AND POST PER CCAUSD No. 249.1
- ⑤ INSTALL NEW ORDINANCE POST AND SIGN PER DETAIL ON SHEET D-2 AND CCAUSD No. 249.1
- ⑥ REMOVE EXISTING ORDINANCE SIGN PANEL AND INSTALL NEW ORDINANCE SIGN PANEL



GRAPHIC SCALE

BENCHMARK
 NO SURVEY

BASIS OF BEARING
 NO SURVEY

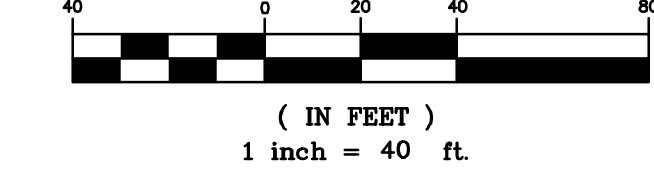

APPROVED	

PEDESTRIAN STUDY - LAS VEGAS BLVD
 UPDATED NO OBSTRUCTIVE USE DRAWINGS
 RUSSELL ROAD TO SAHARA AVENUE
 CLARK COUNTY, NEVADA, DEPARTMENT OF PUBLIC WORKS

PRELIMINARY DRAWINGS

90%
 FOR REVIEW

DESIGNED BY: SRA
 DRAWN BY: SAS
 CHECKED BY: KWA
 DATE: Nov 17, 2012 - 2:38pm

SCALE	
HORIZ:	AS SHOWN
VERT:	N/A
FIELD BOOK	NONE

SHEET No
C-17
 SHEET 21 OF 24

Date: November 17, 2012 - 2:38pm / User: devin.moore
 Path: K:\LV_PublicTrans\092061019 - Clark County Strip Ped Study\CAD\Plan Sheets\092061019_Plan_Sheets\092061019_AE_2011_Dfcs.dwg / Xref: X092061019_Reinforcement Line.X092061019_WhiteLinesNew.X092061019_TB_Enclave_Offices.Palazzo_entrance
 This document, together with the concepts and designs presented herein, is intended only for the specific purpose and client for which it was prepared. Plans or drawings shall not be used for any other purpose without the written consent of the engineer and architect.

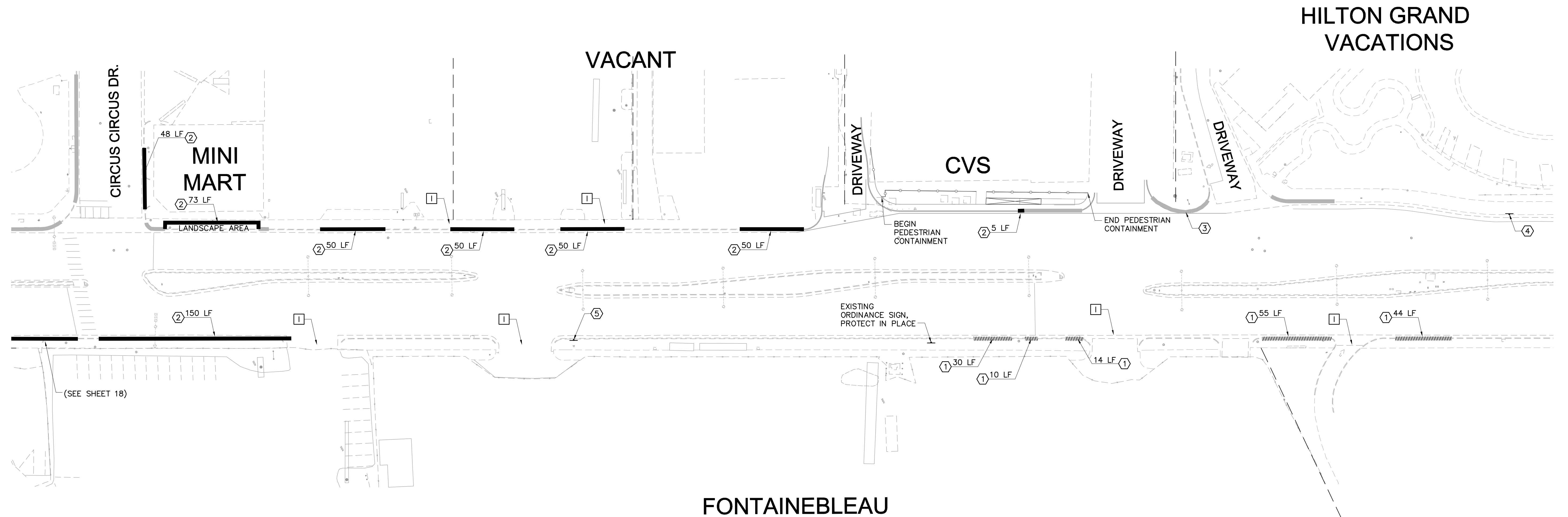

(SEE SHEET 18)

LEGEND	
	EXISTING TOP OF CURB WHITE LINE
	INSTALL 6" TOP OF CURB WHITE LINE
	REMOVE EXISTING TOP OF CURB WHITE LINE
	INACTIVE DRIVEWAY

NOTE:
PROTECT EXISTING 6" WHITE LINE UNLESS NOTED OTHERWISE

NOTE:
TOPOGRAPHIC INFORMATION SHOWN ON THESE PLANS WAS DEVELOPED
BASED ON A SEARCH OF BEST AVAILABLE RECORDS AND INFORMATION.
LOCATIONS AND CONDITION OF IMPROVEMENTS SHOWN ARE SUBJECT TO
CHANGE AND SHALL BE VERIFIED IN THE FIELD.

- CONSTRUCTION NOTES**
- ① REMOVE EXISTING WHITE PAINT
 - ② PAINT NEW 6" WHITE LINE
 - ③ RE-PAINT EXISTING 6" WHITE LINE
 - ④ REMOVE EXISTING ORDINANCE SIGN AND POST AND REINSTALL NEW ORDINANCE SIGN AND POST PER CCAUSD No. 249.1
 - ⑤ INSTALL NEW ORDINANCE POST AND SIGN PER DETAIL ON SHEET D-2 AND CCAUSD No. 249.1
 - ⑥ REMOVE EXISTING ORDINANCE SIGN PANEL AND INSTALL NEW ORDINANCE SIGN PANEL



BENCHMARK
NO SURVEY

BASIS OF BEARING
NO SURVEY

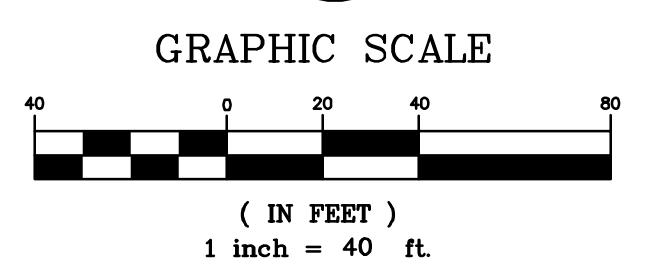

PEDESTRIAN STUDY - LAS VEGAS BLVD
 UPDATED NO OBSTRUCTIVE USE DRAWINGS
 RUSSELL ROAD TO SAHARA AVENUE
 CLARK COUNTY, NEVADA, DEPARTMENT OF PUBLIC WORKS

PRELIMINARY DRAWINGS
90%
FOR REVIEW

DESIGNED BY: SRA
 DRAWN BY: SAS
 CHECKED BY: KWA
 DATE: Nov 17, 2012 - 2:38pm

SCALE
 HORIZ: AS SHOWN
 VERT: N/A
 FIELD BOOK NONE

SHEET No
C-18
 SHEET 22 OF 24

APPROVED

Date: November 17, 2012 - 2:38pm / User: devin.moore
 Path: K:\LV_Public\Trans\0920061019 - Clark County Strip Ped Study\CADD\Plan Sheets\0920061019_D1 to Sahara Jan 09.dwg / Xref: X0920061019_AE_2011_D1toSahara;X0920061019_TopofGrade;X0920061019_WhiteLinesNew;X0920061019_TB;Encore Offsites;Palazzo entrance
 This document, together with the concepts and designs presented herein, is intended only for the specific purpose and client for which it was prepared. Release of any information contained herein without written authorization and approval by Embrey and Associates, Inc. shall be without liability to Embrey and Associates, Inc.

HILTON GRAND
VACATIONS



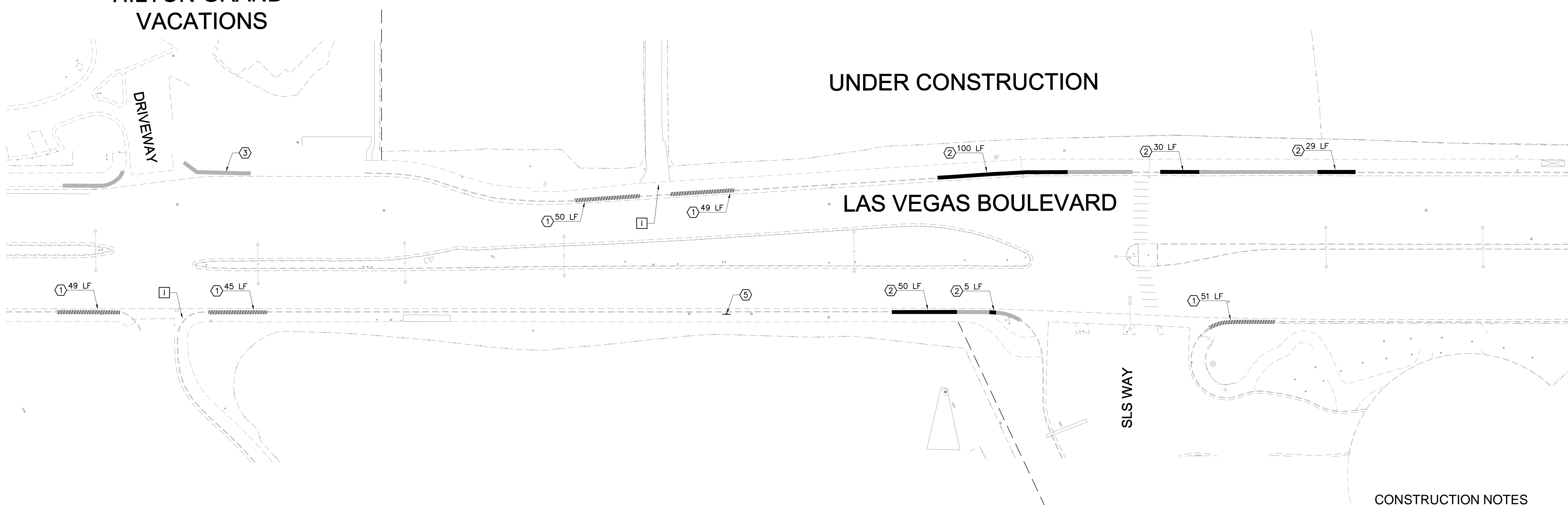

UNDER CONSTRUCTION

LAS VEGAS BOULEVARD

SLS WAY



LEGEND

-  EXISTING TOP OF CURB WHITE LINE
-  INSTALL 6" TOP OF CURB WHITE LINE
-  REMOVE EXISTING TOP OF CURB WHITE LINE
-  INACTIVE DRIVEWAY

NOTE:
PROTECT EXISTING 6" WHITE LINE UNLESS NOTED OTHERWISE

NOTE:
TOPOGRAPHIC INFORMATION SHOWN ON THESE PLANS WAS DEVELOPED
BASED ON A SEARCH OF BEST AVAILABLE RECORDS AND INFORMATION.
LOCATIONS AND CONDITION OF IMPROVEMENTS SHOWN ARE SUBJECT TO
CHANGE AND SHALL BE VERIFIED IN THE FIELD.

CONSTRUCTION NOTES

- ① REMOVE EXISTING WHITE PAINT
- ② PAINT NEW 6" WHITE LINE
- ③ RE-PAINT EXISTING 6" WHITE LINE
- ④ REMOVE EXISTING ORDINANCE SIGN AND POST AND REINSTALL NEW ORDINANCE SIGN AND POST PER CCAUSD No. 249.1
- ⑤ INSTALL NEW ORDINANCE POST AND SIGN PER DETAIL ON SHEET D-2 AND CCAUSD No. 249.1
- ⑥ REMOVE EXISTING ORDINANCE SIGN PANEL AND INSTALL NEW ORDINANCE SIGN PANEL

BENCHMARK
NO SURVEY

BASIS OF BEARING
NO SURVEY

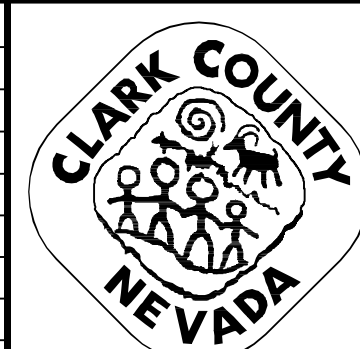
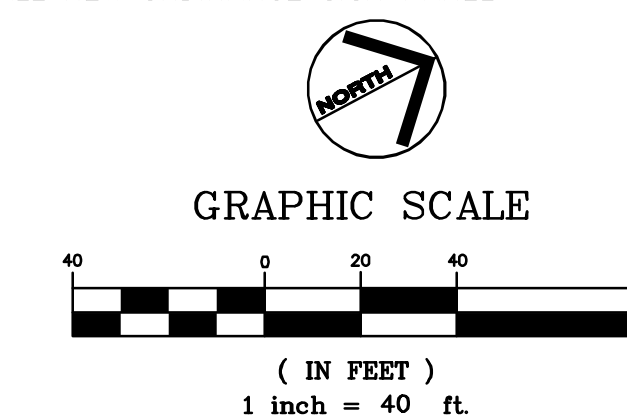

PEDESTRIAN STUDY - LAS VEGAS BLVD
 UPDATED NO OBSTRUCTIVE USE DRAWINGS
 RUSSELL ROAD TO SAHARA AVENUE
 CLARK COUNTY, NEVADA, DEPARTMENT OF PUBLIC WORKS

PRELIMINARY DRAWINGS

90%
FOR REVIEW

DESIGNED BY: SRA
 DRAWN BY: SAS
 CHECKED BY: KWA
 DATE: Nov 17, 2012 - 2:38pm

SCALE
 HORIZ: AS SHOWN
 VERT: N/A
 FIELD BOOK NONE

SHEET No
C-19
 SHEET 23 OF 24

APPROVED

Date: November 17, 2012 - 2:38pm / User: devin.moore
 Path: K:\LAV_PublicTrans\0920061019 - Clark County Strip Ped Study\CADD\Plan Sheets\0920061019_D1 to Sahara Jan 09.dwg / Xref: X0920061019_Refer\Reinforcement Line.X0920061019_AE_2011_D1toSahara;X0920061019_TopofRoad;X0920061019_WhiteLineNew;X0920061019_TB;Encore Offsites;Palazzo entrance
 This document, together with the concepts and designs presented herein, is intended only for the specific purpose and client for which it was prepared. None of our employees shall be authorized to make any alteration or adaptation by any person or persons, and no person shall be authorized to reproduce or disclose the contents of this document without written consent from Clark County and Associates, Inc. and its subcontractors.

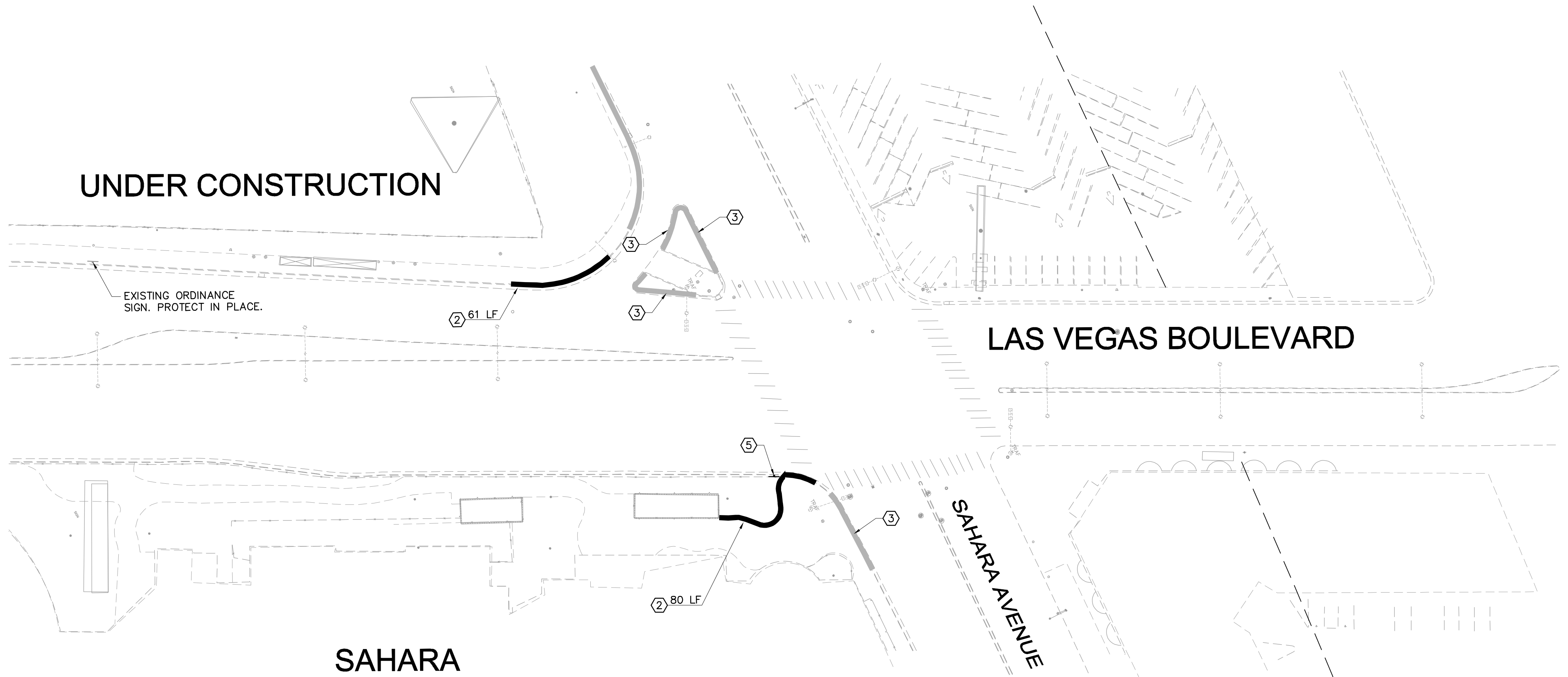

- LEGEND**
- EXISTING TOP OF CURB WHITE LINE
 - INSTALL 6" TOP OF CURB WHITE LINE
 - REMOVE EXISTING TOP OF CURB WHITE LINE
 - INACTIVE DRIVEWAY

- CONSTRUCTION NOTES**
- ① REMOVE EXISTING WHITE PAINT
 - ② PAINT NEW 6" WHITE LINE
 - ③ RE-PAINT EXISTING 6" WHITE LINE
 - ④ REMOVE EXISTING ORDINANCE SIGN AND POST AND REINSTALL NEW ORDINANCE SIGN AND POST PER CCAUSD No. 249.1
 - ⑤ INSTALL NEW ORDINANCE POST AND SIGN PER DETAIL ON SHEET D-2 AND CCAUSD No. 249.1
 - ⑥ REMOVE EXISTING ORDINANCE SIGN PANEL AND INSTALL NEW ORDINANCE SIGN PANEL

NOTE:
 PROTECT EXISTING 6" WHITE LINE UNLESS NOTED OTHERWISE

NOTE:
 TOPOGRAPHIC INFORMATION SHOWN ON THESE PLANS WAS DEVELOPED
 BASED ON A SEARCH OF BEST AVAILABLE RECORDS AND INFORMATION.
 LOCATIONS AND CONDITION OF IMPROVEMENTS SHOWN ARE SUBJECT TO
 CHANGE AND SHALL BE VERIFIED IN THE FIELD.

BENCHMARK
 NO SURVEY

BASIS OF BEARING
 NO SURVEY

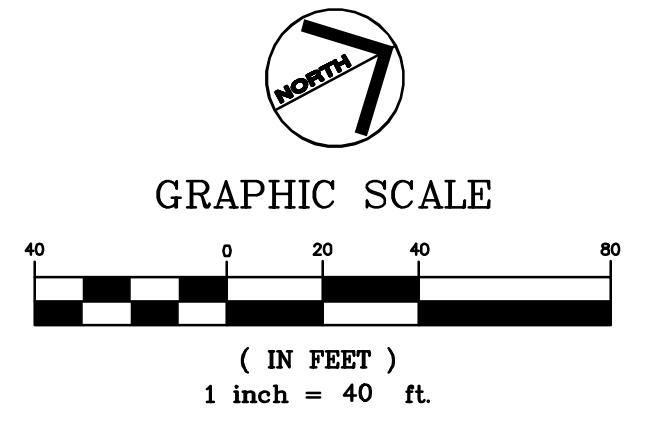

PEDESTRIAN STUDY - LAS VEGAS BLVD
 UPDATED NO OBSTRUCTIVE USE DRAWINGS
 RUSSELL ROAD TO SAHARA AVENUE
 CLARK COUNTY, NEVADA, DEPARTMENT OF PUBLIC WORKS

PRELIMINARY DRAWINGS
90%
 FOR REVIEW

DESIGNED BY: SRA
 DRAWN BY: SAS
 CHECKED BY: KWA
 DATE: Nov 17, 2012 - 2:38pm

SCALE
 HORIZ: AS SHOWN
 VERT: N/A
 FIELD BOOK NONE

SHEET No
C-20
 SHEET 24 OF 24

APPROVED _____

EXHIBIT C

Chapter 16.11 - OBSTRUCTIVE USES OF PUBLIC SIDEWALKS

Sections:

- 16.11.010 - Purpose.
- 16.11.020 - General definitions.
- 16.11.030 - Establishment of the resort district.
- 16.11.035 - County policy against obstructive uses of public sidewalks.
- 16.11.038 - Notice in the resort district.
- 16.11.040 - Prohibition of obstructive uses.
- 16.11.050 - Designation of "No Obstruction Zones."
- 16.11.060 - Structures.
- 16.11.070 - Storing and unloading materials on public sidewalks.
- 16.11.080 - Removal of "No Obstruction Zone" designations.
- 16.11.090 - Penalty for violation.
- 16.11.100 - Private enforcement.
- 16.11.110 - Severability.

16.11.010 - Purpose.

The board finds that due to vehicle congestion, long delays and increasing costs, it has become increasingly more attractive for residents and visitors to use the public sidewalks on Las Vegas Boulevard South (the Strip) rather than to drive or to ride. Since, traditionally, the major emphasis along the Strip has been on automobile transportation and not on pedestrians, the existing pedestrian environment is inadequate as a transportation system and lacking in many safety features. Moreover, a great number of persons are engaged in uses of the public sidewalks which create undue obstruction, hindrance, blockage, hampering, and interference with pedestrian travel. Large numbers of pedestrians are walking in the streets when the public sidewalks become congested and many pedestrians are crossing against the traffic signal indications. In recognition of the need for improvement of the pedestrian environment and the need for accessible public sidewalks, it is necessary to enact the following regulations.

(Ord. 1617 § 1 (part), 1994)

16.11.020 - General definitions.

- (a) "Pedestrian travel" includes nonvehicular travel by persons on foot, as well as vehicular travel by persons with disabilities in wheelchairs or similar devices.
- (b) "Level of service" or "LOS" means a series of measures that define the relative degree of convenience for different pedestrian traffic volumes and densities, as determined by
- (c) "Crosswalk" means any above or below grade structure or surface portion of a roadway at an intersection or elsewhere distinctly indicated for pedestrian crossing by signs, lines or other markings on the surface.
- (d) "Public sidewalk" means that portion of a highway between the curb lines, or the lateral lines of a roadway, and the adjacent property lines, intended for use of pedestrians, and shall also include crosswalks, medians and traffic islands. For the purposes of this chapter, "public sidewalk" shall include private property upon which a limited easement of public access has been granted. However, no provision of this chapter shall be construed to limit any right of the private property owner to restrict or limit the use of that private property.
- (e) "Obstructive use" means:
 - (1) Placing, erecting or maintaining an unpermitted table, chair, booth or other structure upon the public sidewalk, if the placing, erecting, or maintaining of the table, chair, or booth is not protected by the First Amendment or if the placing, erecting, or maintaining of the table, chair, or booth is protected by the First Amendment but is actually obstructive;
 - (2) Forming a cordon or line of persons across the public sidewalk;

- (3) Carrying banners or signs, upon the public sidewalk which actually causes an obstruction on the sidewalk;
 - (4) Placing or storing equipment, materials, parcels, containers, packages, bundles or other property upon the public sidewalk which actually causes an obstruction on the sidewalk;
 - (5) Placing, erecting or maintaining an unpermitted fixed sign upon the public sidewalk;
 - (6) Sleeping upon the public sidewalk;
 - (7) Obstructing, delaying, hindering, blocking, hampering or interfering with pedestrian passage, including passage to or from private property; or
 - (8) Any use of the public sidewalk that causes the LOS for the public sidewalk to decline below LOS C, as determined by the methodology used in Chapter 13 of the Highway Capacity Manual and Las Vegas Boulevard South Pedestrian Walkway Study.
- (f) "LOS C" means a pedestrian flow on a sidewalk of less than or equal to ten pedestrians per minute per foot as specified and defined in the Highway Capacity Manual, Special Report 209, a copy of which is filed with the office of the county clerk.
 - (g) "Permitted obstructive use" means:
 - (1) Any obstructive use of the public sidewalk by public safety equipment, including but not limited to, street signs, traffic signals, fire hydrants, utility poles and street and sidewalk lighting; and
 - (2) Any obstructive use of the public sidewalk for purposes of construction, maintenance or repair of the public safety equipment, right-of-way (or equipment therein) or adjoining private property, conducted by or pursuant to a valid construction permit issued by the Clark County department of public works, Clark County building department or Nevada Department of Transportation;
 - (3) Any obstructive use of the public sidewalk resulting from:
 - (A) An encroachment or structure constructed pursuant to the ordinances, rules, regulations or laws of the United States, the state of Nevada or Clark County, or
 - (B) The construction, modification, addition or attraction upon abutting private property occurring or in place before May 1, 1994;
 - (4) Any newsrack licensed pursuant to Clark County Code Chapter 16.08 unless such newsrack causes a degradation of the LOS to LOS C or less as provided in Section 16.11.040(e);
 - (5) Any conduct "arguably protected" by the National Labor Relations Act until or unless such conduct is determined to be unprotected pursuant to a decision of the National Labor Relations Board;
 - (h) "Arguably protected" as used in subsection (g)(5) of this section has the same meaning as in San Diego Building Trades Council v. Garmon, 359 U.S. 236, 79 S. Ct. 773 (1959).
 - (i) "Street performer" is a member of the general public who engages in any performing act or the playing of any musical instrument, singing or vocalizing, with or without musical accompaniment, and whose performance is not an official part of a sponsored event.

(Ord. 3626 § 1, 2008; Ord. 1617 § 1 (part), 1994)

(Ord. No. 3916, § 1, 11-16-2010; Ord. No. 3986, § 9, 10-4-2011)

16.11.030 - Establishment of the resort district.

For purposes of this chapter a resort district is established as Sections 9, 10, 15, 16, 17, 18, 20, 21, 22, 27, 28, and 29 of Township 21 South, Range 61 East, Mount Diablo Meridian, Clark County, Nevada.

(Ord. 3626 § 1, 2008; Ord. 1617 § 1 (part), 1994)

16.11.035 - County policy against obstructive uses of public sidewalks.

It is the policy of Clark County that no obstructive use, other than a permitted obstructive use, shall be permitted upon any public sidewalk of the resort district of the Las Vegas Valley if the obstructive use, if allowed to occur, would:

- (a) Cause the LOS for the sidewalk to decline below LOS C; or
- (b) Result in a significant threat to or degradation of the safety of pedestrians.

(Ord. 1617 § 1 (part), 1994)

16.11.038 - Notice in the resort district.

Signs shall be posted at least every quarter of a mile in the resort district and the statement **"RESORT DISTRICT: NO OBSTRUCTIVE USES PERMITTED ON PUBLIC SIDEWALKS AT LOCATIONS DESIGNATED BY A WHITE STRIPE, PURSUANT TO CLARK COUNTY CODE CHAPTER 16.11."**

(Ord. 1617 § 1 (part), 1994)

16.11.040 - Prohibition of obstructive uses.

No obstructive use shall be permitted on public sidewalks in the following areas, which areas shall be designated by the placement of pavement markings on the public sidewalks or signs designating the limits of the no obstruction zones, or plaques, monuments or medallions placed in the public sidewalks:

- (a) On or within any crosswalk, including but not limited to all portions of a public sidewalk located in or on a median, traffic island or other structure within, across or over or under a public street or roadway;
- (b) (1) In or within one hundred fifty feet of any mid-block crosswalk, as measured from the crosswalk parallel to the sidewalk curb toward the direction of approaching vehicular traffic, and
(2) In or within fifty feet of any mid-block crosswalk as measured from the crosswalk parallel to the sidewalk curb away from the direction of approaching vehicular traffic;
- (c) (1) In or within one hundred feet of any crosswalk located at an intersection of streets or highways, as measured parallel to the sidewalk curb in the direction of approaching vehicular traffic from the point of curvature of the curb or the marked edge of the crosswalk, whichever is less, and
(2) In or within fifty feet of a crosswalk located at an intersection of streets or highways, as measured parallel to the sidewalk curb away from the direction of approaching vehicular traffic from the point of curvature of the curb or the marked edge of the crosswalk, whichever is less;
- (d) In or within fifty feet of any driveway providing ingress into or egress from any private or non-public property, as measured parallel to the sidewalk curb outward from the point of the curb cut;
- (e) On or within any section of the public sidewalk which has been determined to have an average LOS of C or below, during the hours at which LOS declines below LOS C, as determined by a traffic study conducted by a registered professional engineer or the Clark County department of public works according to the methodology set forth in the Las Vegas Boulevard South Pedestrian Walkway Study.

(Ord. 1617 § 1 (part), 1994)

16.11.050 - Designation of "No Obstruction Zones."

" The board of county commissioners shall adopt a map, to be prepared by the Clark County department of public works, of the H-I zoning district which clearly sets forth those portions of the public sidewalks where obstructive uses, other than permitted obstructive uses, shall be prohibited based upon the factors set forth in Section 16.11.040, above.

- (a) These areas shall be designated "NO OBSTRUCTION ZONES" and shall be clearly marked by the county by the placement of pavement markings on the public sidewalks or signs designating the limits of the no obstruction zones, or plaques, monuments or medallions placed in the public sidewalks, by declaring same.
- (b) Pavement markings on the public sidewalk or signs designating the limits of the "No Obstruction" zone, or plaques, monuments or medallions placed in the public sidewalk marking areas deemed to be no obstruction zones on the basis of LOS, as set forth in Section 16.11.020, shall also specify the hours during which the area is a no obstruction zone.
- (c) No person shall be in violation of this chapter for obstructive use of a no obstruction zone if the no obstruction zone is not designated.

(Ord. 1617 § 1 (part), 1994)

16.11.060 - Structures.

No person shall erect, place or maintain any building, booth, structure, table, chair or other object in whole or in part, upon any public sidewalk unless such use is a permitted obstructive use as set forth in this chapter.

(Ord. 1617 § 1 (part), 1994)

16.11.070 - Storing and unloading materials on public sidewalks.

(a) No equipment, materials, parcels, containers, packages, bundles or other property may be stored, placed or abandoned in or on the public sidewalk. This provision shall not apply to materials or property held or stored in a carry bag or pack which is actually carried by a pedestrian or items such as a musical instrument case or a backpack which is temporarily placed next to a street performer for that street performer's use unless said musical instrument case or backpack actually obstructs the sidewalk in violation of this chapter;

(b) Except in designated loading zones, vehicles may not stop in traffic lanes to load or unload equipment, materials, parcels, containers, packages, bundles or other property onto the public sidewalk.

(Ord. 1617 § 1 (part), 1994)

(Ord. No. 3916, § 1, 11-16-2010)

16.11.080 - Removal of "No Obstruction Zone" designations.

No unauthorized person shall willfully remove, alter, cover or otherwise harm a pavement marking, sign, plaque, monument or medallion marking a no obstruction zone.

(Ord. 1617 § 1 (part), 1994)

16.11.090 - Penalty for violation.

Any person who violates any of the provisions of this chapter is guilty of a misdemeanor and upon conviction shall be punished by imprisonment in the county jail for a term not to exceed six months or by a fine not to exceed one thousand dollars, or by both such fine and imprisonment.

(Ord. 1617 § 1 (part), 1994)

16.11.100 - Private enforcement.

The owner of private property abutting the public sidewalk may use any remedy available at law or equity to enforce the provisions of this chapter.

(Ord. 1617 § 1 (part), 1994)

16.11.110 - Severability.

If any section of this chapter or portion thereof is for any reason held invalid or unconstitutional by any court of competent jurisdiction, such holding shall not invalidate the remaining parts of this chapter.

(Ord. 1617 § 1 (part), 1994)



 Kimley-Horn
and Associates, Inc.
WWW.KIMLEY-HORN.COM

6671 Las Vegas Boulevard South
Suite 320
Las Vegas, Nevada 89119
702-862-3600